

## **Reforestation in the Pacific Islands**

A Manual for Peace Corps Volunteers Involved in Community Forestry Projects in Papua New Guinea, Tonga, Fiji, Western Samoa, Solomon Islands, Cook Islands, Marshall Islands, Micronesia and the Philippines

Kevin Murray  
Peter Impara  
Margaret Stephens  
Technical Consultants

Illustrated by Barbara Cushmore Pretz  
Edited by Sandy Dechert  
and John Maxwell

Prepared for the Peace Corps  
by Rogers, Golden & Halpern, Inc.  
1216 Arch Street  
Philadelphia, Pennsylvania 19107  
1987

Peace Corps  
Information Collection and Exchange  
M0033  
1990

**Peace Corps  
Information Collection & Exchange  
M0033**

### **INFORMATION COLLECTION & EXCHANGE**

Peace Corps' Information Collection & Exchange (ICE) was established so that the strategies and technologies developed by Peace Corps Volunteers, their co-workers, and their counterparts could be made available to the wide range of development organizations and individual workers who might find them useful. Training guides, curricula, lesson plans, project reports, manuals and other Peace Corps-generated materials developed in the field are collected and reviewed. Some are reprinted "as is"; others provide a source of field based information for the production of manuals or for research in particular program areas. Materials that you submit to the Information Collection & Exchange thus become part of the Peace Corps' larger contribution to development.

**Information about ICE publications and services is available through:**

**Peace Corps**  
Information Collection & Exchange  
1111 - 20th Street, NW  
Washington, DC 20526  
USA

Website: <http://www.peacecorps.gov>  
Telephone : 1-202-692-2640  
Fax : 1-202- 692-2641

Add your experience to the ICE Resource Center. Send materials that you've prepared so that we can share them with others working in the development field. Your technical insights serve as the basis for the generation of ICE manuals, reprints and resource packets, and also ensure that ICE is providing the most updated, innovative problem-solving techniques and information available to you and your fellow development workers.

This manual may be reproduced and/or translated in part or in full without payment or royalty. Please give standard acknowledgment.

## 1. Introduction

### Objectives of This Manual

This manual has been designed as a reference and technical information tool for use by community development workers and others interested in forestry and reforestation projects in the islands of the South Pacific. It is an attempt to present - in clear, non-technical language - background and "how to" information necessary for Peace Corps Volunteers and other forestry workers to understand the basic issues surrounding problems of deforestation and to initiate and plan local-level reforestation projects.

Traditionally, transfer of information on forestry management techniques has relied heavily on application of temperate zone techniques to tropical areas. But such techniques do not always work well when applied under widely different environmental and social systems. This manual represents an attempt to provide an easy-to-use information resource especially geared toward forestry-related activities in the tropical Pacific islands.

No single manual can include all the information the forester may need or want to know. The community forester must be prepared to face a range of different situations and problems and to adapt to changing circumstances. Even within the South Pacific island area, conditions differ greatly. There are a variety of environmental issues, languages, and cultural differences between and within island groups. Time spent consulting host country experts may prove extremely useful to the novice forester.

Successful community forestry projects, like other development efforts, must take into account the needs and desires of community members, the physical and environmental factors affecting the locality, and the availability of materials, resources, and skills necessary to carry out each step of the project.

This manual provides basic information about things the forester should know. It should assist the forester in understanding:

- The causes and effects of deforestation.
- The potential of forestry projects for improving quality of life and the environment.
- Environmental, sociopolitical, and economic factors to consider in implementing forestry projects.
- Forestry systems applicable to the Pacific, especially agroforestry systems.
- Techniques and field methods for establishing and maintaining successful projects.

### What is Forestry?

Forestry may be defined as the practice of managing forests and forest related resources for the purpose of achieving desired goals, such as conservation or production. Forests provide numerous benefits, particularly in **conservation** of natural resources and production of important commodities - food and fodder, fuel and timber. Forestry programs may have many different goals, including afforestation, fire protection, watershed management, erosion control, agroforestry, fuelwood production, and regeneration of species diversity or natural habitats for wildlife.

Forestry practices differ from place to place. They depend upon the natural resources, land use patterns, and policies and regulations that are in effect. One Pacific island country may have young, or maturing, forests that are the symbol of a recovery from past mismanagement or natural disasters. In another country, mature forests may be under severe pressure and never fully recover. On other islands, forestry projects may have reclaimed denuded slopes, turning them into viable food and wood-producing projects.

### The Problem of Deforestation

Humans have always impacted the world's forests. Humans probably changed vegetation patterns first with the discovery of fire, which they used to drive animals toward waiting hunters. With the advent of farming, fires were used to clear fields for livestock grazing or cultivation. American Indians cleared forests with fire to extend the range of the buffalo. For over 5,500 years a burgeoning Chinese population, requiring enormous amounts of food and fuel, expanded into forested lands, cut the trees,

and planted crops As early as 3000 B.C. the Phoenicians used wood to produce pottery, metals, and glass products for a world market The famous cedars of Lebanon were used to build ships, palatial temples, and palaces. Plagues, wars, and agricultural and industrial needs decimated vast stands of European forests. It was not until coal and steel replaced wood for heating and shipbuilding, and the concept of sustained yield became popular, that the pressure on European forests was reduced. Today, forest clearing in Africa and Southeast Asia remains a serious problem. Large stands of previously unreachable tropical forests are being cleared for agriculture, cut for firewood, and harvested to supply timber to a voracious foreign market (For additional information see Carter and Dale, 1981.)

Man's historic use of forest byproducts has reduced the world's original forest area to at least one-third to one-half its original size. According to the World Resources Institute, at the current rate of destruction, at least 225 million hectares of the world's remaining tropical forests will be deforested and 10 to 20 percent of all animal and plant life will be lost by the year 2000.

This wholesale loss of forested lands has had a number of adverse effects. Tropical forests provide humanity with a cornucopia of benefits. Tropical forests are living museums and laboratories that have yielded only a tiny fraction of their treasures to scientific study. Many useful chemical products essential for making medicines and pharmaceuticals originate in tropical plants. More than 50 percent of modern medicines come from the natural world, many from tropical forests.

Industrial products derived from moist tropical forests include volatile essential oils, gums, resins, latexes, and other exudates, steroids, waxes, rubber, fibers, dyes, tanning agents, turpentine, edible oils, rattans, bamboo, flavorings, spices, and pesticides.

The cutting of forests and pressures on forest lands have led to soil erosion, water shortages, landslides, flood damage and destruction of productive lands, and siltation of rivers and streams. This is of particular concern in the Pacific islands, where forested watershed areas located upstream from agricultural lands are vital to agricultural productivity. These upland water catchments are the principal sources of water for all downstream uses, and their destruction can cause serious harm to the environment and to people who make their living from the land. Furthermore, rain forests are home to 200 million people, who rely on the forests for the necessities of life. Tropical forests provide them with fruit, nuts, and honey, along with fibers and wood for building, fuelwood for cooking, lighting and heating, and fodder for livestock raising.

Coastal dwellers relying on fresh and salt water fish products are affected as well. Soils eroding off bare slopes into streams may eventually be discharged into estuaries and mangrove swamps that serve as breeding grounds for fish. Increased sedimentation can eliminate breeding grounds, as well as destroy aquatic plant material that is an integral part of the food chain This destruction will ultimately ruin the local fishing industry.

Perhaps the most important aspect of deforestation is the effect on the environment. Tropical forests exhibit an incredible array of life. During the ice ages, they served as refuges where less hardy species survived and later repopulated the temperate zones. Whereas temperate, northern forests are unlikely to contain more than 10-15 tree species per hectare, a single hectare of Amazon rainforest has been known to contain up to 230 species. A natural forest ecosystem is an integrated web of organisms that has developed over millions of years into a state of dynamic equilibrium, wherein it is able to adjust to changes in the environment and reestablish a balance. When a great deal of stress is placed upon the system for a long period of time, the system is less able to adjust to the changing conditions. This often results in the destruction of a portion of the wide array of plant and animal species indigenous to the system (see Illus. 1-1). The resulting degradation could even generate local or regional climatic changes, with as yet unknown consequences.

Island species of flora and fauna (plants and animals) are particularly vulnerable to prolonged periods of stress. In general, islands have less species diversity than do most continental land areas. With fewer species, the competition is lessened, as is the resistance of any individual species to introduced (non-native) pests, diseases, and other stresses.

Forestry projects can help resolve these problems by restoring the productive capability of the land and by preventing further destruction. (For more information, see Jordan and Farnworth, 1982; Spears, 1982; and Poore, 1983.)

## Causes of Deforestation

There are many factors influencing the cutting of trees and the depletion of forest resources in the Pacific islands. In recent years, increasing pressure has been placed on forest lands for economic and social as well as political reasons (Plumwood and Routely, 1982). The social, economic, and environmental causes and effects of deforestation are closely interlinked, and any proposed strategy for reversing the trend must consider these linkages.

Illus. 1-1. Effects of the Forest Ecosystem

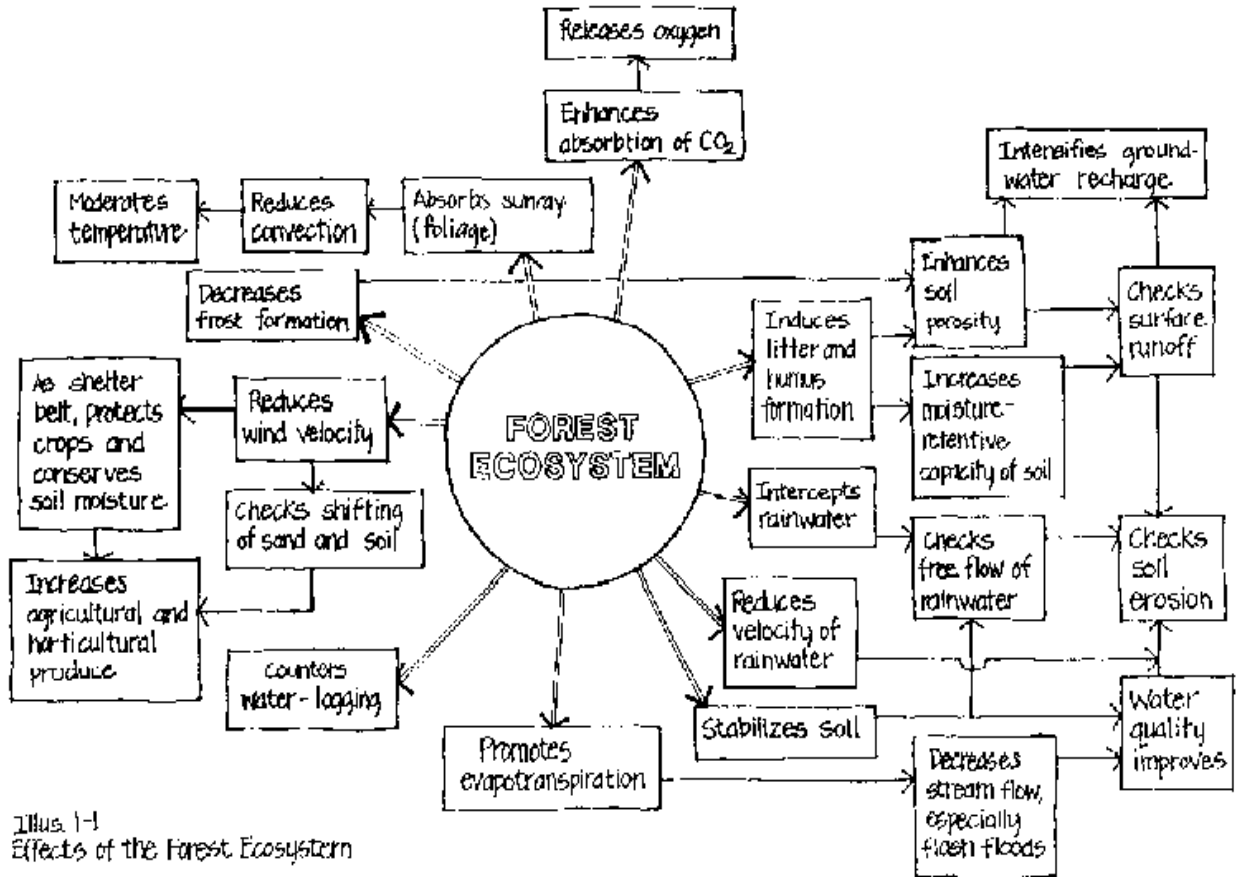

Illus. 1-1  
Effects of the Forest Ecosystem

The major causes of deforestation in the South Pacific islands are summarized below.

### Human Intervention

The main effect of human intervention in forest areas has been to decrease the extent of the forest and to change the types and quantities of vegetation. When land is intensively cropped and then abandoned, the natural tree cover and soil fertility may never return. Instead, shrub and grass species may become the dominant type of vegetation. Once established, these species are difficult to eradicate. This has already occurred in many islands with the establishment of *Imperata* grasses.

The high population growth rate in the Pacific islands (3-5%) has contributed to increasing pressure on land and other natural resources. As population increases, the amount of forest land usually declines, because demand for land for food production and other uses intensifies.

### Settlement Patterns

Increases in population, as well as migration among and within island regions, have created an ever-increasing demand for land that can be used for settlement and/or cultivation. As population increases, the size of individual farms or plots usually decreases. Particularly for subsistence farmers, cultivation intensifies as plot size is reduced. This usually results in soil depletion and related problems such as declining crop yields. In many of the south Pacific islands, land ownership is tribal

or clan-related. This system can be a major concern in forest management. Additionally, population pressure forces many farmers onto land unsuitable for cultivation.

In some areas, disputes over land ownership may result in misuse of the land or poor land management practices. Without clear title to the land, people tend to be less concerned with proper management.

The construction of roads and expansion of transportation networks into forested areas also lead to the destruction or damage of forest lands. The new roads open marginal lands to migrants, who often lack the skills or incentives to properly manage the land.

### *Agricultural Practices*

**Shifting cultivation** (swidden agriculture) is a common practice in many regions of the world. In the Pacific islands, shifting cultivation usually occurs on steep, sloping lands; tilling with draft animals, machinery, or by hand takes place on the flat lowlands. In shifting cultivation, farmers intensively crop a given area of land for a few seasons until the productivity of the land and crop yields decline. They then leave the exhausted land fallow (uncultivated) and move on to farm elsewhere. The natural cycle of regeneration of land takes about 25 years; in order for soil fertility to be restored, the land should lie fallow for at least five to ten years. But because of increasing pressures for land, in many areas of the Pacific this "resting" time has been reduced to 4 years or even eliminated entirely.

**Slash and burn** techniques for clearing forests are associated with shifting cultivation practices. They enable the farmers to quickly and easily prepare new land for cultivation. The combination of shifting cultivation and related practices often leads to deterioration of soil conditions and loss of protective ground cover. These practices can be particularly damaging to the land, causing rapid depletion of soil nutrients and loss in productivity, erosion, landslides, uncontrolled fires, and flooding.

Increased population pressures often lead to the use of **margin lands**, or fragile areas that are ill-suited for cultivation under normal circumstances. Overgrazing of livestock can also lead to losses in productive capacity. Animals tend to eat favorable vegetative species, leaving behind hardy weeds. Unmanaged herds tend to compact soil, thus reducing water infiltration, exacerbating runoff, and precluding the establishment of favorable plants.

**Monoculture**, or single crop systems, may reduce species diversity and resistance to disease and pest infestations. Continuous corn or upland rice cultivation on steep slopes promotes erosion. Unless proper long-term management techniques are applied, intensive cropping of single species can also deplete soil fertility.

### *Inadequate Forest Management Practices*

In many regions, there has been insufficient education, promotion, coordination, and enforcement of proper **forest and watershed management** practices. Natural mangrove forests on many islands have been destroyed by overcutting and clearing by loggers and farmers. The revegetation of these lands is often not enforced, or is difficult to enforce due to the demand for tillable land. Farmers with poor land management skills receive limited training due to underfunded government programs. In many cases, government bureaus in charge of forestry and agriculture fail to coordinate related programs, thus undermining long-term government objectives. Even where properly conceived programs do exist, enforcement and public support for them may be limited. Environmental education and extension efforts are required to teach officials and farmers the importance of sound management techniques.

### *Economic Pressures - Demand for Timber, Fuelwood*

The demand for **timber** has increased, in part due to the growth in world market demand and in part to pressure on small- island economies to develop cash-generating activities to pay foreign debts. Between 1963 and 1983 the amount of wood produced for markets increased from 1.8 to 3.0 billion cubic meters. Ten developed countries account for 65 percent of the total value of timber imports.

Over the past 35 years the production of **fuelwood** has more than tripled. Nearly 1.5 billion people in 63 countries, or about 60 percent of the people who depend on fuelwood as their principle source of energy for cooking and heating, are cutting wood faster than it can grow back. At present

consumption rates, the estimated fuelwood deficit will double by the year 2000. (For more information, see Arnold, 1983.)

### *Natural Disasters*

Although typhoons, floods, landslides, fires, and other natural disasters occur naturally, their frequency and impact can be significantly increased when the delicate balance of the ecosystem is disturbed, or when natural protection is lessened.

## **Basic Uses of Forest Products**

### *Food and Fodder - Agroforestry*

The natural forest provides an abundance of food resources to both people and animals. Since settlement and cultivation of forest land areas began, people have learned to use the forest in various ways, including the application of **agroforestry**, in which both food crops and trees are grown on the same land for a variety of end uses. More recently, the concept of agroforestry has gained greater attention as a means of alleviating some of the pressure for tillable land and protecting forest and land resources. (See Domingo, 1981; 1980; Spurgeon, 1979; King, 1979a; Douglas and Hart, 1976; Stewart, 1981; and Adeyoju, 1980.) Agroforestry is an integrated cropping system in which a mix of outputs may be produced on a continuing, sustainable basis. These products may be roughly divided into food and fodder outputs from both tree and agricultural crop cultivation, and wood products from the trees.

### *Fuelwood*

Fuel for cooking, lighting, and heating is extremely important to the upland farmer. In most areas wood is the cheapest, most familiar, and most easily available form of fuel. Fuelwood for use on upland farms - fallen limbs and branches and dead trees - is usually collected from forested areas. In some regions, the forest areas have been destroyed or have receded so that the time and effort required for collection and preparation of wood for domestic use has become excessive. The shortage is so extreme in some areas that people are forced to cut down productive trees for use as fuel.

In agroforestry projects where the major products are food and fuel, the species may differ, but the basic techniques for cultivation and planting are similar to those in crop-producing agroforestry systems. The specific techniques for each type of agroforestry project are covered in Chapter 7.

### *Commercial Fuelwood*

In addition to its use as a domestic fuel, wood may also be in demand for commercial uses: wood chips used as a boiler fuel in place of gas or oil for steam production or electric power generation; production of chemicals or liquid fuels through fermentation or gasification; or small-scale commercial fuelwood or charcoal production for outside (usually urban) markets. Commercial fuelwood production may take place in a large corporate operation or may be practiced by small farmers, and may be part of monoculture or inter-cropped agroforestry systems. This manual is primarily concerned with the considerations for small-scale agroforestry systems.

### *Timber*

In upland areas, timber is used for construction of poles and fencing and for other farm purposes. Timber may also be in demand where markets for pulpwood and electrical transmission posts exist. High-quality timber is also a major export item for many Pacific countries.

## **Environmental Benefits of Forests**

As mentioned earlier, intensive cutting of forests and cultivation of marginal lands has resulted in rapid soil erosion and decline in productivity in many areas. Under certain conditions, erosion and declines in productivity can be effectively controlled through proven methods of forest farming. Besides requiring low inputs, forest farming techniques that utilize specific plant species can stabilize soils on sloping lands, help maintain and improve soil fertility, and positively impact the microclimate of an impacted area.

### *Stabilization*

Particular tree and plant species, having deeper, more extensive root systems than other species, function to hold down soil on lands and reduce its tendency to erode when impacted by water and wind. This protective characteristic is enhanced when planted on sloping lands.

Tree and plant litter, consisting of leaves, branches, etc., also serve as ground cover, protecting the soil surface from the pounding of heavy rains and consequent splash-erosion. The organic matter, together with the root system which penetrates into deeper subsoil, increases water filtration and absorption of water through the soil. This is particularly important during times of heavy rainfall (see Illus. 1-2).

By increasing soil stability, trees and plant cover may also prevent the damaging effects of siltation on streams and other water supplies, including irrigation channels, that may be caused by movements of large masses of soil.

Extremes in water levels - very low levels or flooding - may also be regulated with proper forest management. Well planned placement of vegetation may also serve as an effective windbreak, reducing wind erosion and damage to crops.

Illus. 1-2. The Forest Water Cycle

### Illus. 1-2 The Forest Water Cycle

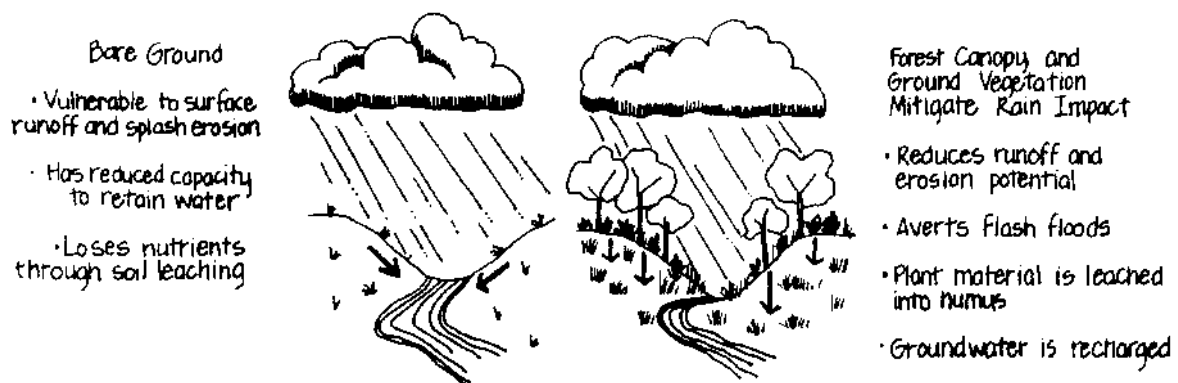

### *Soil Fertility*

Certain species of trees and ground cover, by stabilizing topsoil and preventing erosion, can minimize depletion of soil and soil nutrients. In addition, plants with long taproots can help recover nutrients lost to the subsoil layers through leaching and infiltration. These nutrients can then be "recycled" back to the surface as organic matter, or litter that decomposes and re-releases vital nutrients. Trees and their roots also, improve the soil structure and thus the movement of nutrients and water by producing increased amounts of stable particles and avoiding hardpans.

Legume plants or trees have the ability to "fix," or convert, atmospheric nitrogen into usable form for plants, thus contributing to the fertility of an area. Some legumes, especially those with long taproots, function better than others in improving soil fertility.

In agroforestry projects, legumes serve an important role in providing the essential nutrient nitrogen to the trees and interplanted crops. Nitrogen is otherwise depleted rapidly and can be replaced only with application of large amounts of organic material or expensive chemical fertilizers.

### *Microclimate Regulation*

Both the tree and plant foliage, which serve as a windbreak and canopy, and "mulch" created by tree litter, provide shading and thermoregulation (temperature regulation) by reducing direct solar radiation upon the soil surface and moderating the water flow, thus regulating moisture content of soil. By reducing sunlight, the effects of high temperatures - such as hardening or "baking" of the soil surface,

which causes impenetrability, and increases in evaporation of surface water - are reduced. By maintaining the temperature balance at the soil surface, the microclimatic conditions for decomposition of organic matter and release of soil nutrients are improved. The forestry canopy also protects the microclimate from drastic fluctuations between day and night temperatures. A full or partial canopy will also ensure the viability and productivity of light intolerant plant species. Because coffee trees are an understory plant, under certain conditions productivity is increased when grown under other tree species. Leafy vegetables are also sensitive to strong sunlight. Proper shading can extend their growing season.

### *Other Benefits*

The natural forests provide many other non-economic benefits that are sometimes difficult to measure and not always recognized by individual farmers or policy-makers.

- Forests, through their photosynthetic and filtering actions, provide a natural source of oxygen and pollution control.
- Wildlife habitat is another important forest product.
- The diversity of plant species in the forest and their spatial arrangements can deter insect proliferation. Careful study of these species and their interrelationships may provide important lessons for farmers and agronomists.
- As stated, 50 percent of the world's medicines come from natural plants.
- Plant species are also a source of aesthetic and recreational pleasure, and can serve as a "classroom" for important environmental education work.

The primary reasons for implementing forestry programs and projects are as follows:

- Conservation and protection of land quality, species diversity, and natural habitats for economic and non-economic benefit.
- Increase of productivity to develop economic and food production potential.

The type of project chosen and the species selected for forestry projects depend upon the specific conditions and needs of the project area. In the following chapters, we will discuss how the community forester can help to determine these needs.

## **2. The role of the community forester**

### **Project Planning**

The success or failure of a project can most often be attributed to the amount of time spent by the project planners on short- and long-term project planning. This includes identifying and coordinating national, regional and community needs, establishing realistic goals, and effectively mobilizing available resources. In this chapter and in Chapter 4, we will deal with the various aspects of the project planning process and the role of the community forester in that process.

### **Levels of Planning**

Project planning takes place at several different levels, all of which are interdependent.

<b>Level of Planning</b>	<b>Examples</b>
National Policies/Program	- Set up an integrated reforestation program
Specific National Goals	- Plant 10,000 trees in two years - Launch community education campaign
Regional Level	- Select project areas - Establish community nurseries - Train workers



Projects (Local Level)	
Operational Plans & Management Plans	<ul style="list-style-type: none"> <li>- Organize project management team</li> <li>- Plan a forestry program</li> <li>- Set up tasks</li> <li>- Obtain financial and other support</li> </ul>

These various levels of planning must overlap and work together if the goals and objectives of the parties involved are to be successfully implemented. Policies and programs such as nationwide tree-planting programs will only become a reality if they are understood and established with strong regional and local support, and if local communities have some measure of control over the specifics of the project management and implementation.

This chapter is primarily concerned with the level of planning of most direct concern to the community forester: the project/community level. The forester should help the community keep sight of its long-term goals while setting up a schedule and mechanism for accomplishing the various tasks necessary to achieve them. Three basic project planning levels and tasks within each level are as follows:

### Long-Term Plan

- Identify community needs.
- Define specific environmental or economic problems characteristic of the area.
- Identify and choose appropriate solutions.

### Medium-Term Plan

- Outline specific task-oriented objectives.
- Organize a project team. Provide each member defined roles and responsibilities.
- Complete a feasibility study that focuses on technical and financial resources, market availability, and social and environmental opportunities and constraints.
- Design a project monitoring and evaluation system.

### Short-Term Plan

- Set a schedule for completion of specific tasks.
- Begin implementation.
- Provide project management. Provide record keeping, maintenance and work schedules.

In establishing a realistic program to accomplish these tasks, the forester must construct a multi-faceted plan, one that sets out the expected time frame for completion of the various tasks and allows sufficient room for expansion or changes to the plan as time goes on and experience is gained. The technical aspects of project planning are covered in Chapter 4.

### The Importance of Community Involvement

The initial step in developing a forestry project is defining the objectives of the community. (Since Volunteers also work with individual farmers, the term "community" is used consistently in this chapter to include individual farmers.) It is crucial for foresters to understand the concepts of self help, "meaning the ability of local people to formulate goals and use their own resources and know-how to improve the quality of their lives," and **appropriate technology**, "the use of technologies and methods suited to the physical and cultural environment in which they are used."

The success of a forestry project depends in large measure upon the level of commitment and involvement of the community. If the participants feel they have defined the project(s) most crucial to their needs and stand to gain from it, they will be more inclined to provide full moral and physical support. Throughout the project development process there should be mutual respect and cooperation between the community and the forester. The community forester should always make an effort to welcome participation in each step of the project development process. The objective of the community forester is not to "do everything" but to assist the participants in planning and carrying

out their own projects, using local resources and know-how in harmony with local practices and customs. The failure of foresters to understand participants' goals and apply appropriate capital and energy-intensive technologies has led to the failure of many projects.

### *Identification of Community Needs*

One of the first tasks faced by the community forester is the determination of the specific needs of the community in which a project is to be undertaken. This is true even in cases where there is a specific goal, such as establishment of a fruit tree nursery, which has been set forth by government policy or plan. (See "Planting for the Future : Forestry for Human Needs," FC41, available from ICE.)

The role of the Volunteer is to help the community determine needs, and then design and carry out the project. In order to identify community needs, the forester must establish an adequate base of information about the physical environment, culture, local customs and practices, economic conditions, past and present forestry programs, and sociopolitical factors that affect the community.

The forester should conduct an "inventory" of information resources. It is essential to identify key community leaders, other development workers (current or past) within the area or in neighboring regions, government officials, and others, and develop a good working relationship with them. These contacts can prove invaluable in expediting the development of the project. They will help the forester gain access to materials, information resources, transportation, permits, a labor pool and other support essential to the project's success.

When establishing a network of contacts and a base of support for projects and programs, the community forester should always be aware of local customs. It is important to extend the accepted courtesies and follow standard protocol in all written and verbal communications. Proper respect should be extended to village elders, religious leaders, or government officials, and appropriate dress and decorum should be maintained. In all cases, the forester should maintain the highest level of professionalism.

Basic information may be gathered through formal interviews or informal discussions or surveys with key people. It is generally helpful to draw up a list of questions or topics for discussion in advance. These surveys can be used to obtain general information or gauge the opinions of people on various subjects. It is important when asking questions to be aware of sensitive issues, and to approach them carefully. Biased questions (such as "Don't you think the price of fertilizer is too high?") should also be avoided.

When working in the community, the forester can also obtain a great deal of information through **observation**. Planting practices of farmers, for example, can be learned through observation, and such things as the informal social structure (which farmers are the leaders, which are most respected by their peers, who are the innovators, etc.) can also be observed. Joining the farmers when they are out working in the field may allow the forester to learn how they work and what they think about their work, to observe their methods, and to gain their trust. Many farmers enjoy companions when working in the field.

### *Project Support*

As discussed above, it is important for the community forester to establish a network of contacts among community members, technical specialists, and leaders and officials. One way of gaining support from the various groups is to form a **task force** or **advisory group**. Depending upon the particular circumstances, this group may focus on a narrow task, such as providing technical information or services to the project, or it may bring together individuals or groups whose coordinated, cooperative support is needed for the success of the project, and who normally would not meet together. In some cases, the forester may need to help the group work out disagreements through negotiation or other means.

Do not limit the types of people in the task force. If social taboos restrict certain individuals or groups from participating, it may be necessary to talk directly to them on an individual basis. In many societies, women are vital forces in maintaining the family and community: they contribute significantly to agricultural and other productive activities and serve important roles as economic decision-makers. Often, however, community development and extension projects and policies fail to adequately consider these important contributions and do not consult women or solicit their support.

## *Socioeconomic Surveys*

It is crucial that the community forester and/or project planners understand existing social and economic structure so that they may identify the community's needs as well as the important constraints or potential obstacles. A program or project that responds to "**felt needs**" has a better chance of adoption and success.

Any proposed project must (1) be technically feasible; (2) make economic sense and be economically attractive; (3) be socially acceptable; and (4) have the support of important local officials and others.

Farmers "targeted" as participants in a forestry project must be convinced that they will gain something from the project: useful knowledge, a better technique, increased productivity or cash income, etc. They must also be convinced that the potential benefits are worth the effort, that is, the time and money they must invest. (This is a simple form of cost/benefit analysis.) Only then does the project have a reasonable chance for success.

The socioeconomic survey should be designed to measure the specific conditions of the given area, such as available land, labor, and capital resources. It also provides a baseline measurement of the existing situation against which conditions throughout the various stages of project implementation can be measured and the impact of the project analyzed.

**Field Questions.** Types of information to be gathered might include the following:

### Physical & Environmental

- Topography, climate, weather patterns, soil, water, wind; in short, factors influencing species selection and plant growth (see Chapter 3).
- Past projects.

### Economic

- Economic conditions.
- Land ownership, plot size, income levels, availability of investment capital, equipment.
- Current and potential products and markets.
- Access to markets and means of transport.
- Past, current, or planned economic development activities in the area.
- Policies affecting level and type of production, agricultural prices, etc
- Existence of cooperatives for marketing or production.
- Availability of capital through loans or other credit schemes.

### Social

- Formal community organization, leaders.
- Informal social structure.
- Sex roles, defined work and leadership roles.
- Important traditions and beliefs.
- Spirit of cooperativism versus individualism.
- Social class distinctions and differences.
- Level of education, skills, and knowledge.
- Degree of openness to innovation.

### Political

- Factors affecting the project development.
- Formal political structure of the area.

In some areas this type of information may be unavailable from villagers, thus requiring research on the part of the forester. Regional and national government agencies are often a source of reliable information. Public and private universities have departmental libraries with extensive collections of research papers and books on topics ranging from geologic conditions to tribal cultures. Private relief

organizations such as CARE are also a good source of information. In some cases they can provide material published by other international organizations. Conduct a survey of foreign governments with offices in the country. Many have agricultural liaisons or aid offices that are willing to volunteer services. Another source of information and possibly materials is plantations. Because of negative publicity normally received by their operations, plantation managers may be willing to help out in any way possible. With a little imagination a forester can locate numerous sources of information.

#### *Survey of Demand for Forest Products*

The community forester should also be aware of the current demand and supply situation for forest products, including timber, fuelwood, food, fodder, and fertilizer. A good survey should emphasize the main sources of supply - local, imports from other regions, from large plantations or private lands - and demand - local farm or non-farm households, local markets, or outside markets. Access to markets and cost of transportation should also be studied.

The survey may be conducted by researching existing sources of information such as agricultural research institutions, government agricultural or commerce statistics, and other reports and local market information. Alternatively (and often more accurately), data may be obtained through direct inquiries of farmers, extension workers, and others.

The survey should be designed to identify key problem areas, shortages or surpluses, and urgent needs, in order to assist the project planning efforts. Assistance from trained statisticians or surveyors can greatly aid the forester and should be sought before attempting a full-scale formal survey.

#### *Available Resources*

The survey should gather information on local resources, as follows:

**Land:** total area available, distribution and tenure patterns, soil quality, topography, etc.; current land uses.

**Labor:** total labor supply, availability throughout the year (need for farm labor varies significantly with planting and harvesting and seasonal cycles), non-farm or competing labor needs and other sources of income, level of skills training and education.

**Capital:** total available, ability and willingness of farmers to invest in forestry project, availability of government or other sources of financing.

**Technical Information:** in-country technical and private support organizations, foreign support organizations, universities or trade schools, libraries.

**Material Support:** seed sources, research stations, extension workers, host country and foreign donor organizations,

The inventory of available local resources can be conducted by interviewing local officials, representatives of financial institutions (banks providing loans in the area), and the farmers themselves. For a list of international sources of information, see Appendix A.

#### *Existing Systems of Production*

It is important to understand current practices, and the reasons behind them, in order to properly introduce new or innovative techniques. An effort should also be made to determine the success or failure of earlier attempts to introduce forestry projects or new production techniques to the area. Any proposed project should incorporate existing techniques as appropriate insofar as possible. For example, when introducing a variety of fruit that is not normally propagated in the area yet has promising market value, choose one that is familiar to the farmer rather than an exotic. If the objective is erosion control or fuelwood production, dedicate a major portion of the plot to a locally accepted variety while reserving a smaller portion to a less known but equally productive variety. When introducing new planting techniques or varieties of food crops, extension agents often dedicate several rows of a cornfield for experimental purposes while the remaining portion is planted in the traditional manner. This technique allows the farmer to see the difference in yields between the

traditional method of planting and the new method. (For more information on strategies for planned change, see Zattman and Duncan, 1977.)

### **Forestry Extension Techniques**

Forestry extension, as practiced by the community forester, is the art and science of converting information from research and past experience to a practical level for use by local people who may not be specifically trained in forestry techniques. It is a two-way process: the extensionist demonstrates proven practices to the farmers, the farmers share their knowledge and field experience with the extensionist, and jointly they work to identify problem areas and to seek solutions.

The scientific or technical aspects of forestry extension will be covered in other sections of this manual. Right now we are more concerned with the "art," or more subjective aspects of extension work, which involve the ability of the community forester to understand the needs, wants, and customs of the local people, and to effectively communicate new information and new ideas to these people.

#### *Important Characteristics of the Forestry Extensionist*

Effective forestry extensionists share a number of important qualities:

- Ability to understand the needs of the community
- Leadership qualities - ability to help organize and motivate others
- Trustworthiness and responsibility
- Effective communications skills
- Sensitivity to community concerns
- Technical knowledge, skills, and research ability - knowing where to find information
- Availability and accessibility to community
- Sense of humor
- Flexibility and adaptability to changing circumstances.

In addition to the above characteristics, an extension agent must have the insight and skills to determine the most appropriate extension methods for the given situation. There are many different ways of transmitting information. The most effective will be chosen based on the abilities of the extension worker and the materials and resources available in the community. Resources, methods, presentations, formal and informal education techniques, and the introduction of new ideas are discussed below. (For additional information on extension technique, see "Agricultural Extension, M 18," available from ICE.)

#### *Resources*

Perhaps the most essential resource for effective extension work is the personal experience and individual qualities of the Volunteer. The forester's own education and training, the knowledge and experience, and the ability to communicate and to seek help from other sources as necessary all affect the quality of extension activities.

However, within every community there is a substantial body of knowledge stored in the memories and experiences of local people, as well as in the more formal channels of written materials, technical personnel from international or national development agencies, educational institutions, and others. It is the task of the community forester to become familiar with the resources available and to seek assistance as necessary.

#### *Methods*

The various methods available to the Volunteer may include everything from prepared audio-visual materials (such as slides or films) to the expertise of teams of technicians who visit the community to provide classroom or field training. On the other hand, the forester may not have access to sophisticated electronic equipment or to outside resources and may have to rely on verbal presentations, simple written or graphic materials, signs and posters, field sessions, demonstration plots, etc. If group sessions with community members are not possible, the forester may have to rely on individual visits to households and farms within the community.

The effectiveness of the extension methods has more to do with the care with which they are chosen and prepared than with their "fanciness." In most cases, the more that can be shown visually, the better the information will be transmitted and remembered. Wherever possible, it is a good idea to demonstrate new concepts or techniques using physical models or by actually doing the task in a field situation: for instance, by convincing one farmer to use a small portion of his hillside to demonstrate integrated cropping of fuel, food, and fodder crops. This will reinforce the concepts and enable participants to try out the methods themselves.

It is important for the community forester to plan training sessions in advance, and to time visits or meetings so as not to interfere with the important daily or seasonal tasks of the participants. The concept of "meetings" may be unfamiliar in some village settings. It is the responsibility of the forester to learn local customs and to work with the local people to structure appropriate settings for group discussion and decision making.

**Making Presentations.** When making public presentations, formal or informal, the forester should be careful not only with timing (not to make the presentation too long, or to present too much material at once) but also to **keep things simple!** It is important when describing or demonstrating forestry techniques to explain not only "how" to do things, but "why" - why it is important that this or that be done in such a way, and what can happen if it is not done properly. Such concepts may be extremely complicated to explain. As a rule, the community forester should try to explain things one step at a time in logical sequence, using concrete examples that refer to local condition and events, and repeating where necessary. There should always be sufficient time allowed for questions and review. Where appropriate, written reference materials should be provided. (For additional information see, "Teaching Conservation in Developing Nations," available from ICE.)

Using humor in verbal presentations is a good way to keep the attention of the audience and to help them remember. Of course, the presenter should always be aware of sensitive issues and avoid offending anyone.

Where audio-visual materials are not available or are in short supply, effective visual aids can be created fairly simply using common materials, stick drawings, skits, or role plays. (For additional information on audio-visuals see "Audio-visual Communication Handbook" available from ICE.)

**Use of Formal Educational Techniques.** It is important to direct educational programs not only at the adults in the community, but toward children and youth as well. In many situations, in fact, it is often through children that new ideas and techniques are passed on to others. The extensionist may be able gain the trust and support of school administrators, teachers or leaders of youth groups, and parents in order to conduct educational sessions or start forestry projects with children.

When "teaching" in a formal classroom situation, become familiar with teaching methods and classroom protocol. This is best done by observing classes beforehand and by talking with teachers or other experienced people. Get ideas from extension agents whose job is to conduct training sessions for their co-workers and farmers. The time spent will be valuable in terms of gathering ideas as well as making contacts. It is also important to gear the presentation to the audience's level of understanding, and to encourage their active participation as much as possible.

**Informal Teaching.** The extensionist must be open to all opportunities for informal educational work. Such occasions can include community festivals, sporting events, agricultural shows, and other events that can provide the ideal opportunity for giving presentations or even just the chance to meet informally and talk over new ideas. Field trips to interesting sites, or to neighboring farms, may also be arranged when possible. A contest challenging school children to collect the greatest number of seeds can meet the needs of a nursery program and teach environmental awareness at the same time.

The Volunteer can only be effective if he or she is trusted by the community members. It is important, then, for the forester to get to know individuals and to enlist their support. The forester should know and understand the formal and informal channels of community organization in order to use them effectively.

**Introducing Innovations and New Ideas.** As an extension worker, the community forester may often be called upon to introduce new ways of thinking about things or accomplishing various tasks. These

range from different methods of organizing group efforts and administering meetings, to new techniques of planting, to introducing new species of trees or new uses for forest products.

When introducing new information, the Volunteer should observe a number of guidelines:

- Determine the need for change
- Diagnose the specific problem requiring a new approach
- Act as a catalyst to build the environment for change preparing those who will be part of it
- Locate a farmer or group willing to start a demonstration program
- Locate and facilitate the transfer of funds for project development
- Encourage the participants to embark upon and follow through with the required steps
- Assist in the transition by providing information as well as follow-up support
- Provide technical support throughout the length of the project

### **Planning and Managing a Forestry Project**

Up to this point, we have discussed the initial steps in the project planning process: situational analysis and community needs assessment. Here we continue with approaches to project planning and implementation by listing criteria for project selection and evaluation, setting up a work plan, and discussing monitoring and evaluating.

#### *Criteria for Project Selection and Evaluation*

No single set of criteria is adequate for judging the feasibility and chances for success of a proposed project. Economic factors, although important, should not be considered in a vacuum. The project must meet social and cultural criteria of acceptance and work within the particular environmental constraints.

**Environmental Criteria.** The project should meet the following environmental criteria :

- Be sustainable while meeting community needs
- Enhance existing crop production strategies, not destroy them
- Conserve the forest ecosystem and its multiple benefits
- Avoid competition between species for nutrients, light, and water
- Use tree species and management practices appropriate to local physical and climatic conditions
- Plant and harvest in a non-disruptive manner.

The criteria for a project utilizing appropriate technology include the following:

- Make optimal use of local human and material resources
- Be based on felt needs of the community and have full community participation
- Increase self-reliant capabilities.

**Economic Evaluation.** During an economic evaluation or cost/benefit analysis of a project, the costs or inputs needed, such as fertilizer, money for seeds or seedlings, volunteer and paid labor, etc., are compared with the value of the potential expected benefits, or outputs: food, fodder, fuelwood, timber. Simply stated, if the benefits outweigh the costs, then the project makes economic sense.

**Economic Criteria.** Economic objectives for a project include these goals:

- Maximizing benefits at least cost
- Maximizing returns on investment
- Achieving specified production goals
- Achieving economic yields greater than those of the current system
- Opening new markets for products

In an agroforestry project, there will also be indirect costs and benefits. Indirect costs may include the negative short-term effects of increased water runoff when trees are first planted, or aggressive competition by introduced tree species. Positive effects, or benefits, include improvements in soil fertility brought about by nitrogen-fixing trees.

For proper economic evaluation, each of the inputs, outputs, and indirect costs and benefits should be identified and valued. For some, such as the environmental costs of lost soil, valuation is quite complicated.

Economic evaluation can be done at the micro, or individual project, level or the macro, or political, level. At the micro level, only factors directly affecting the individual farmers or community are considered. At the macro level, a wider range of factors are used.

Economic evaluation can be done before the project is begun, during the planning phase, or as a final evaluation after the project is completed. The techniques used in all cases are similar.

#### *Existing Up a Work Plan*

The work plan is a useful way for project planners to determine proper timing as well as to outline the various needs - technical assistance, financial backing, labor, and time-that must be met to make the project operational.

**Timing considerations** are crucial to the success of forestry projects. For this reason, a community forestry worker should be thoroughly familiar with the agricultural crop cycle, seasonal weather patterns, and availability of rainfall throughout the year. This background information should be collected as early in the planning process as possible (see Chapter 4).

The establishment and planting of trees in a nursery should be timed so that seedlings will be of proper size for outdoor planting at the time of year when weather conditions are ideal. The schedule of tasks to be completed for the forestry project should, insofar as possible, complement rather than interfere with the other duties and responsibilities of farmers and workers. Schedule the more time-consuming, labor-intensive tasks such as land clearing or site preparation at times during which labor is relatively plentiful and other agricultural tasks are few.

**Task-Oriented Planning** is one useful approach to setting up a work plan. Divide the project into a sequence of steps, or tasks, from beginning to end, and describe the activities required to complete each of the steps. The development of the work plan must take place with the full participation of the community. A table or chart can be used to list the project goals as well as the various tasks required to attain them. As the tasks are laid out, the resource, material, labor, and time requirements can be determined for each step of the project.

An example of one such table is shown below:

<b>Task</b>	<b>Equipment and Material</b>	<b>Labor</b>	<b>Time</b>	<b>Cost</b>
Land Clearing	Surveying equipment, machetes, shovels	5 persons	2 days	\$_____
Site Preparation	Tractors or hand plows, fuel and oil, levels	4 persons	5 days	\$_____
Nursery	Wood, soil, fertilizers	2 persons	3 days	\$_____
Planting	Stock	4 persons	5 days	\$_____
Maintenance	- -	2 persons	Daily	\$_____

Each of the tasks listed can be broken down further into subtasks, with the requisite needs and requirements listed. Possible problem areas and contingency plans should be noted as well.

#### *Network Analysis in Project Planning*

A forestry project of any size comprises numerous different activities that must be carefully timed and carried out in proper sequence so that the whole work program proceeds smoothly within the allotted time and budget constraints.

**Network analysis** is one technique developed to help control and schedule complex operations. It is concerned with finding the optimal way to manage a complete system, such as all the activities involved with forestation of a particular area.



The basic methodology of network analysis can be used to assist in planning even relatively small-scale forestry projects (Illus. 2-1). The basic technique involves a graphic representation of the events needed to complete a task or activity in the logical sequence in which they take place. Circles represent the events and are connected to arrows, which represent the activities themselves.

The system flows from left to right; that is, the activities are drawn in sequential order from left to right. Overlapping or concurrent activities can be also represented. After the logical sequence is graphically represented, a time scale may be attached. Then the network diagram can be analyzed in order to determine, for example, the proper starting time for the project, or to set interim target dates for certain activities, such as planting or harvesting.

Illus. 2-1 Network Analysis

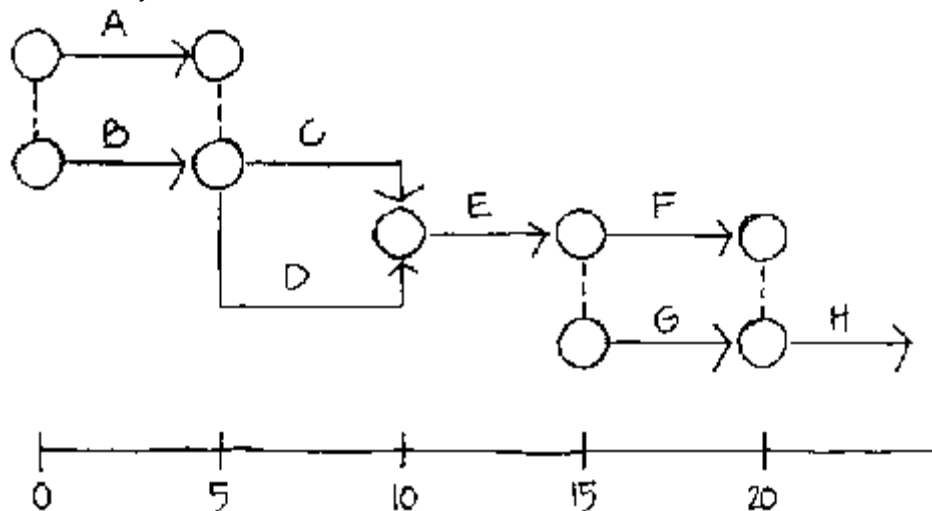

Time Line in Days (example)

A = Prepare nursery beds or containers B = Plant seeds C = Remove seedlings D = Prepare field E = Transport plants F = Fertilize G = Heel - in seedlings H = Maintenance

The analysis can also help to determine the crucial activities that must be completed in order to finish within the targeted time frame. The network can be continually updated and modified as the project progresses, and it will serve as a valuable reference. It can help the project manager adhere to deadlines and evaluate performances by serving as a basis or comparison between targeted and actual accomplishments.

### *Project Monitoring and Evaluation*

Another important aspect of project management is periodic evaluation and feedback. Information should be collected and recorded on a regular basis, as described above, so that it can be analyzed for evaluation purposes. If the project is divided into steps, or sequential tasks, a logical time for evaluation might be at various stages of task completion (mid-term, etc.). For a long-term project, periodic evaluation sessions should be scheduled throughout the year.

The information collected for evaluation provides a basis upon which the planners can make day-to-day changes to improve the project, or organize alternate schemes when necessary. Obtaining feedback at frequent intervals alerts the project managers to problems while they still may be remedied. It also allows modifications in time schedules or techniques as needed.

The information may also be used in presentations to funding organizations, important officials, community groups, or others who have decision-making power. Most outside donors require regular reports and many have their own reporting systems established.

In order to determine whether the project is proceeding satisfactorily and whether it is meeting its stated objectives, it is necessary to set up a system of evaluation based on measurable terms. The "outputs" of a project can be either **qualitative** or **quantitative**. Quantitative measures, such as number of trees planted or volume of wood or fruit collected, are relatively easy to systematically

record and evaluate. Qualitative measures, such as degree of community participation or satisfaction of farmers, are more difficult to accurately describe and evaluate, although they are of great importance. The project manager may want to develop a method of project evaluation in order to judge progress and reevaluate long-term goals.

### **Identifying Sources of Funding and Supplies**

Among the difficulties the Volunteer must be prepared to encounter is the shortage of capital or financial support needed to undertake and carry out a forestry project. This is especially difficult in subsistence-farming areas. Because forestry projects are perceived as long-term and may provide little or no immediate returns to farmers or financiers, start-up capital is not always forthcoming from local sources. Furthermore, it may be difficult to obtain loans from lending institutions because the community may have a bad credit rating due to the failure of past programs. If such is the case, it will be difficult to convince banks to lend capital. Agroforestry projects that provide a relatively rapid return on investment in short-rotation crops while trees reach harvestable size may provide an attractive adjunct to forestry work. A sound financial and work plan may convince banks to lend capital.

To obtain outside support, the community forester can take an "inventory" of potential sources such as government agencies, private investors, charitable organizations, research institutions, or international development agencies:

- Research local or regional library/university facilities
- Contact regional or national offices of the above institutions
- Find out from other community workers where likely sources might be
- Investigate other similar projects that have been funded or financed
- Investigate local lending institutions and farmer cooperatives.

(For information on developing resources, see "Resources for Development," available from ICE.)

It is important to recognize that most outside funding agencies have their own funding "cycles," or specific times when they choose projects to which to allocate funds. Agencies may also have specific requirements or procedures for requesting support. These should always be conscientiously observed.

In developing project proposals, the community worker should describe not only the project itself, but why it is important and how it will benefit the community, and how the community will be involved. The last is the most important. Funding agencies want to be assured the community investment is strong enough to continue a project regardless of the presence of an extension agent. Background information collected as part of the project planning process is important to include in the proposal presentation.

### *Project Team Selection and Labor Requirements*

Once the forester develops a good working relationship with community residents and learns the nature of both the formal and informal organizational hierarchies within the community he or she can begin to select the planning team.

When calculating time requirements for the various project-related tasks, it is important to include time necessary for training, field visits, meetings, etc. Labor requirements for tasks such as land preparation, watering, and planting should be estimated based on experience gained during similar projects, if possible. Contingency plans should be drawn up in case there is a shortage of workers or the project falls behind schedule.

### *Budgeting and Record keeping*

A project **budget**, or cost analysis, helps to estimate the amount of materials and money as well as labor needed. The budget should also include items that cannot be given a money value, such as volunteer services. "In kind" items or donations should also be included.

**Recordkeeping** is another critical aspect of project management. Early in the planning process, a comprehensive system should be set up to monitor finances and document all aspects of project

activities. Financial bookkeeping is essential, particularly where funds are limited. Outside funding sources or farmers themselves must be convinced that their money was properly spent.

When gathering information for purposes of effective community work and project planning, it is important to keep good, up-to-date records, and to take some time to analyze or interpret the information properly. At the end of the day, conversations and observations should be recorded.

The ultimate goal of development projects is to create a self-reliant capability within the community. Therefore, it is important that information be recorded in a form that can be used as a reference even after the community forester leaves the area. Training and reference material, as well as planting times, spacing, site requirements and problems such as insect infestations, should be recorded for **carry-over**. Their effects, solutions, and any changes in plans should also be recorded. This may be the only permanent record available to other community workers or for project workers in other areas.

An **inventory** of equipment and other supplies should be kept so that the progress of the project is not hindered by shortages of needed materials. If machinery is used, maintenance and repair records should also be kept. A checklist of routine maintenance procedures is a good way to keep equipment working properly or to spot problems before they become too serious.

A list of types of records includes the followings

#### Daily

- Work log - tasks accomplished, special problems, meetings, etc.
- Equipment - materials and equipment used, maintenance and repairs performed
- Finances - expenditures or income, purchases, salaries, etc.

#### Monthly

- Financial summary - expenditures and income
- Progress report

#### Annual

- Financial summary and budget analysis (compare projected to actual budget)
- Yearly planning - summarize year's accomplishments, analyze problems, set plan for next stage of project, make changes to original plan as appropriate.

### **3. Natural factors affecting deforestation**

#### **Patterns of Human Settlement**

When the islands were first settled by outside peoples, forests covered a large proportion of the land area. At first, people lived largely from hunting and gathering on forested lands - collecting fruit and nuts, hunting wild game, and using wood for fuel and building shelter. The first inhabitants introduced relatively minor changes to the natural ecosystem. Traditional agricultural practices worked more in harmony than in conflict with the natural systems. Food production methods did not greatly increase levels of erosion and sedimentation and had built-in conservation measures. In the Truk Islands, for example, traditional farmers planted the lower slopes with breadfruit and coconut trees and left the upper slopes left intact. This is an example of a simple agroforestry system that provided soil conservation and protection.

With colonization of the islands, much forest land was taken over for the establishment of plantations, or trees were cut for lumber and fuelwood. Some new tree species, including teak and kapok, were introduced by European settlers. Many of these were produced for the export market.

These changes in land use led to a reduction in the extent of natural forested lands (Poore, 1983). In many cases, little attention was given to the value of natural forests and little effective control over forest clearing or timber harvesting was exercised.

In recent years, the uncontrolled clearing and harvesting of forests has been widely recognized as a serious environmental and economic problem, and reforestation has become a major focus of many island policies.

The following sections outline the major natural factors that influence forestry systems. It is important for the forestry worker to understand the relationships among these factors, and to realize that they play a role in determining the feasibility of any forestry effort.

### **Environmental Considerations**

The tropical region of the Pacific Islands encompasses a wide variety of vegetation, types of habitats, topography, climatic patterns, and soils. Details are presented in Hadley and Lanly, 1983; King, 1979; and Wadsworth and Mergen, 1980.

The nature of the vegetation that grows naturally or that can be successfully cultivated in a tropical area is largely determined by the local ecosystem and its component factors - climate, soil, and topography. But the vegetation itself influences the formation and nature of the soil, as we shall see later on. Vegetation provides organic matter and protects soil from the effects of rainfall, sunlight, and wind.

Lush, luxuriant tropical rain forest vegetation is often thought to indicate high fertility of the soil base. This can be misleading, as the soil may have only a very thin layer of rich topsoil. When the vegetative cover is removed, the soils may become rapidly depleted and unproductive unless it is protected by some other means.

There are substantial differences in topography or terrain among the Pacific islands, ranging from rugged, high islands to limestone terraces and volcanic slopes. Some have flat coastal areas and steep inland mountains. Others, such as the Marshall Island group, are made up of low islands and coral atolls.

### **Climate**

A variety of tropical climates results from wind systems and air mass movements. In general, there is a decrease in temperature as one moves from the equator toward the poles. This general pattern, however, is greatly modified by the physical arrangements of continents, land masses, and oceans, as well as by land relief and the type of ground cover. The combination of these variable factors create **microclimates**, which can be very different from one neighboring area to another.

The term **tropical climate** includes such greatly different climates as those of dense rain forests, savannas, dry deciduous forests, bush, desert steppes, and alpine meadows.

The islands of the Pacific encompass four major climatic types: equatorial, tropical, mountain, and monsoon. Generally, these types are characterized by seasonal patterns of wet and dry periods. Most of the Western Pacific island climates feature high humidity and rainfall.

Among the major climatic factors important to forests and tree growth are rainfall patterns, temperature, availability of sunlight (solar radiation), humidity, and winds. Each of these factors may be subject to seasonal changes as well. Information on the specific climatic patterns of any particular area should be available through a branch of the Weather Service or other climate-related research institution, airports, or government offices. The community worker should make a point of talking to local farmers to find out how seasonal changes affect their work cycles. The relationship between climatic factors and forestry efforts is described below.

#### *Rainfall*

Rainfall is perhaps the most important climatic factor affecting agriculture and forestry in the tropics and subtropics. It can be a limiting factor even in regions with high total annual precipitation rates if the rainfall is unevenly distributed throughout the year. Understanding rainfall patterns and availability of water throughout the year is crucial for forest projects, as farmers must plan planting around adequate water supplies.

Most small farmers do not have the means to install irrigation equipment or manually water large areas of land, so they must rely on the natural water supplies.

Island regions of the Pacific with an equatorial or monsoonal climate usually have very high rates of yearly rainfall. The high total rainfall is due primarily to the great intensity of tropical rains rather than a higher number of days or hours of rainfall throughout the year. The intensity of rainfall generally varies with altitude, with lower-altitude regions receiving rainfall of higher intensity. Many of the mountainous islands have a rainy side and an acid side, with rainfall amounts varying by thousands of millimeters per year. The high intensity of rains in the wet climate, exceeding the receptive or absorptive capacity of the soils, often causes considerable surface runoff. In addition, the driving or pelting of raindrops against the soil surface may cause "sealing," preventing penetration of water and air into the soil. This sealing, in turn, leads to increased runoff, erosion, flooding and even landslides on sloped sites.

In areas with high rainfall and steep slopes, the soil is especially prone to erosion. Therefore, the combined effects of slope and rainfall may determine the feasibility of a project or may influence species selection on a particular site.

In tropical areas where heavy precipitation causes leaching of soil nutrients, the soil is left nutrient-poor, and generally acidic. This factor may have a significant impact on the rate of growth and health of trees, as well as the type of species that may grow in the area.

On the other hand, **evapotranspiration** (evaporation of moisture from the soil surface) may be much higher than precipitation in some tropical areas. As the water evaporates from the soil surface, a higher than normal concentration of salts will be deposited. These salts can be detrimental to plant growth; some plants may not be able to tolerate high salt conditions at all.

It is widely believed that the destruction of forests and reduction of forest areas leads to a reduction in local rainfall, but most evidence indicates that, in fact, the decreased forest area causes more of a change in rainfall distribution patterns than in total amount of precipitation

### *Temperature*

As temperature increases, so does the **weathering potential** of soil. (Weathering is the disintegration and decomposition of rocks into smaller rocks and minerals that eventually change to new minerals.) In the humid, wet tropics, the combination of high temperatures and rainfall results in a significant amount of decomposition or **chemical weathering** of parent material (chemical changes take place, soluble materials are released, and new minerals are synthesized or are left as resistant end products). In more arid regions, **physical weathering** (a decrease in the size of rocks and minerals without appreciably affecting their composition) is more important than chemical weathering.

High temperatures generally lead to a rapid turnover or decomposition of organic matter and a low humus content in the soil. In cooler temperatures and in waterlogged areas, organic matter builds up.

In tropical areas, temperature is affected primarily by altitude. In general, temperature decreases with increasing altitude, although such factors as wind patterns, proximity to oceans and ocean currents, etc., may affect temperature patterns of specific locations.

Temperature affects the types of species that may be successfully cultivated in a particular area. Cool temperature crops such as certain varieties of coffee, for example, do not grow as well in warmer, lower-altitude areas as in the cooler elevated regions. The growth of certain species may be stunted if the temperature range is not ideal. Some species are quite sensitive even to moderate temperature fluctuations.

### *Humidity*

The amount of humidity in the atmosphere varies with total rainfall, its distribution, and the influences of ocean current and wind patterns. Humidity is usually high in equatorial and monsoon climates, but falls to low levels during seasonal dry periods. There may be marked fluctuations in humidity levels from day and night. In rain forest regions, humidity may vary from as low as 70 percent or so during dry days to a fairly constant near-100 percent at night. Humidity influences evapotranspiration - the lower the humidity, the more evaporation may occur, as the water-holding capacity of the atmosphere increases.

Plant growth is affected by the amount of atmospheric humidity. High humidity levels may stimulate the growth of wind- and water-borne fungi, thus leading to an increased potential for transmission of plant diseases.

#### *Sunlight Levels (Solar Radiation)*

Because of the tilt of the earth as it revolves around the sun, solar radiation falls more directly on tropical than on polar regions. This contributes to the generally warmer temperatures in the tropics, which often have less seasonal variation than temperate climates.

The intensity of solar radiation directly affects plant growth. Some plant species require long periods of direct sunlight; others require shading. Soils that underlie low-altitude rain forests are protected from direct sunlight by the forest canopy. When shade is removed, intense sunlight falling on bare soils can cause to rapid evaporation of soil moisture and breakdown of organic materials. The increase in solar radiation will also raise the air temperature close to the temperature of the soil surface, and this may be detrimental to growth of some plants. Shade trees may be planted to protect for cooler-temperature crops.

#### *Wind*

Wind may affect the moisture content and susceptibility of soils to erosion. Badly timed or managed cultivation, especially on slopes, can induce soil erosion. Bare ground exposed to wind and sun loses moisture faster than ground covered with vegetation. Measures for wind control attempt to reduce wind speed at ground level and to increase the moisture content and stability of soil.

The types of wind patterns also influence species selection and site planning. Tall trees with weak trunks and shallow roots are not recommended for areas prone to high, monsoon winds, because the potential damage and loss to the trees and byproducts is too great. In unprotected windy areas, deep rooted or short-stature species are best. Where seasonal winds are more moderate, species with shallow, spreading roots and taller canopies are suitable.

### **Soils and Forestry**

The five groups of factors responsible for the kind, rate, and extent of soil development are climate, vegetation, parent material, topography, and time. (For details, see Tisdale and Nelson, 1975; Baver and others, 1972; and Foth and Task, 1972.)

Soils are formed by the gradual process of weatherization of underlying rock material and decomposition of organic matter. Some are formed from river and ocean deposits. These processes take place over a period of many years. (For additional information on soils see, "Soils, Crops, and Fertilizer Use," available from ICE.)

The soils of the South Pacific islands are of two main origins: **volcanic**, formed from the discharge of volcanoes; and **alluvial**, formed from the build up of sediments from streams, rivers, lakes, and oceans. These soils have four basic components: mineral matter, organic matter, water, and air.

#### *Components of Soil*

**Mineral Matter.** Soils consist of particles of different sizes. These particles have been divided into groups entirely on the basis of size, that is without regard to their chemical composition, color, weight, or other properties. The three major particle categories are **sand**, **silt**, and **clay**. The relative proportion of each of these in a particular soil determines the soil texture. The texture of the soil is directly related to available water capacity, drainage, and resistance to erosion.

Sand particles are of comparatively large size and hence expose little surface compared to that exposed by an equal weight of silt or clay particles. Because of the small surface of the sand particles, the part they play in the chemical and physical activities of a soil is almost negligible. Because sand is relatively large but low in surface area, its chief function is to serve as a framework for facilitating the movement of air and drainage water and contributing to the soil filth (ease of working).

Since sand and silt consist mainly of particles resulting from the breakdown of rocks and minerals, they differ primarily in size and in a given soil. Silt has more surface area and a faster weathering rate and release of soluble nutrients for plant growth.

Chemical weathering on the surfaces of rocks, sand, and silt particles results in the solution of ions that regroup or recombine to form fine particles of clay size. The clay fraction in most soils is composed of minerals that differ greatly in composition and properties from the sand and silt. Clay is composed of alternating layers of molecules that act as exchange sites for nutrients such as nitrogen (N), potassium (K), calcium (Ca), and others. Clay thus adds to the fertility of the soil. However, in the tropics, advanced weathering and prolonged leaching can lead to infertility of these soils. A distinctive red or yellow color, especially in the subsoil, is a sign of extensive weathering.

**Organic Matter.** Organic matter in forest soils is formed from the decayed remains of vegetation and animals that feed off the forest vegetation. As more organic material is added to the soil, it becomes richer and deeper, thus promoting healthy plant growth.

Virgin forest land has a healthy proportion of organic matter (six to nine percent by weight) in its topsoil. Although the organic material is a relatively small proportion of the total soil content, it serves a vital function in maintaining soil health and fertility and in providing a good substrate for plant growth. Organic material tends to stabilize soil and improve water retention capacity (particularly in sandy soils). It is also resistant to erosion and slows hardening of the soil surface under dry conditions. It also improves soil tilth by loosening clayey soils and compacting sandy soils, and stores and subsequently supplies soil nutrients (particularly nitrogen, phosphorus, and sulfur), which are slowly released in usable form as organic matter decomposes.

As land is cleared for cropping, however, the natural process of soil building is disturbed. If continuous cultivation occurs without proper soil management, the **organic matter content** of the soil is greatly reduced. **Tilling** of the land hastens the microbial breakdown of organic matter to the humus. **Humus** is the word used to refer to organic matter that has undergone extensive decomposition and is quite resistant to further alteration. Growing crops takes nutrients from the soil and generally exposes the soil surface to higher temperatures, which also contribute to increased decomposition of organic matter.

The importance of various methods of intercropping and use of leguminous crops to store soil fertility are discussed in Chapter 7.

Two of the most important and characteristic properties of humus are its nitrogen content, which usually varies from 3-6%, and its carbon content, which is 55-58%. Another important property of humus is its cation exchange capacity (CEC). Cation exchange sites absorb cations such as Ca, Mg, and K, and in doing so, humus acts similarly to clay, retaining available nutrients against leaching and maintaining the nutrients in a form available to higher plants and microorganisms. But humus can hold up to 30 times more nutrients than clay; it is of particular importance to sandy or true "tropical" soils. Humus also reduces soil erosion by binding soil particles into a crumb-like structure that is resistant to water flows; and it increases soil infiltration, thus lessening water runoff.

**Soil, Air, and Water.** About half of a soil's volume is composed of air and water. The ability of water to absorb, retain, and supply water to plants is vital to their survival.

Soils lose water through plant transpiration, surface runoff, evaporation, and drainage. High evaporation rates may be particularly problematic during dry periods and with exposed soil surfaces. Natural forest shading, well-planned intercropping, and use of mulch may minimize this problem. Surface runoff losses are especially important on slopes. Soil conservation practices such as contour planting and terracing may improve water retention and decrease erosion.

**Organisms in the Soil.** Organisms include a vast number of plants and animals living in the soil. They range from earthworms to molds. Most organisms are beneficial to soil and plants. They serve the following important functions:

- **Decomposition of organic matter.** Soil bacteria and fungi work to decompose fresh organic matter.

- **Recycling of nutrients.** Releasing plant nutrients tied up in organic matter by converting them into the inorganic, or mineral, form, which is more readily usable by plants.
- **Nitrogen fixation.** Several types of bacteria serve a vital function by "fixing" atmospheric nitrogen (N) and converting it to a useful form for plants. Legumes have a symbiotic (mutually beneficial) relationship with Rhizobia bacteria, for example.

Organisms are normally found in two distinct layers of soil: the topsoil and subsoil. The topsoil is the darker, upper layer, usually six to twelve inches thick. Topsoil is generally more fertile than subsoil, as it contains greater amounts of organic matter (giving it darker color). Topsoil tends to be looser and less clayey than subsoils.

The subsoil is generally much thicker than the topsoil and provides an important moisture reserve, especially during dry periods. In order to encourage the proliferation of beneficial microorganisms in the upper soil layers, the forester must be careful to ensure that the soil is not depleted of organic material.

### *Soil Description and Surveys*

The characteristics and quality of soils vary depending upon climatic conditions, type of parent materials, topography, use, management practices, and age. The differences among soils may range from variations in texture to color, nutrient content, origin, etc. It is crucial these differences in soils be examined and understood by the community forester. When choosing a site for an agricultural or forestry project, the soil is one of the principal factors that should be considered, for some plants may thrive in soils where others will perish.

Soil surveys are a basic tool for determining and studying the basic soil characteristics of an area. They provide useful site selection information for forestry project managers. Soil surveys are usually available from government Soil Service Extension Services or universities.

A soil survey describes and delineates soil boundaries. These boundaries are mapped by a soil scientist and are distinguished by applying the five factors of soil formation: parent material, climate, time, topography, and vegetation. More specific categories for soil delineation include slope, stoniness, drainage, and other characteristics that affect use of the soil by man.

A **soil profile** (Illus. 3-1) is the sequence of natural layers, or **horizons**, in the soil. These layers extend from the surface down into the parent material. All soil profiles contain two or more master horizons. Short descriptions of these horizons follow:

**D - Organic horizons of mineral soils.** These horizons are dominated by fresh or partly decomposed mineral matter.

**A - Mineral horizons.** Directly underlie organic horizons and may contain a large amount of organic matter, giving soil a darker color. These horizons have also leached out (lost) clay, iron, or aluminum.

**B - Horizon of accumulation.** This horizon is an accumulation of clays or humus in the subsoil. The depth and degree of weathering in this horizon is an indication of the age of the soil.

**C - Mineral horizon.** A layer, excluding bedrock, which is only slightly affected by the weathering process.

**R - Bedrock.** Rocks such as granite, shale, sandstone, or basalt.

A **soil series** is a group of soils that have similar profiles. Soils of one series can differ in slope, stoniness or texture of the surface horizon. On the basis of such differences, a soil series is divided into **soil phases**. The soil series and soil phase are the categories of soil classification most used in the soil survey.

After the soil series has been identified, the soil survey contains tables by which the forester can learn the suitability of the soils for growing crops or establishing woodlands. Interpretations for erosion hazard, equipment limitations, seedling mortality, and other categories are listed.



It is not necessary to be highly trained in agronomy and soil science in order to interpret and use the soil profile. Some of the procedures for constructing and interpreting a soil profile description are indicated below.

Using a shovel, simply dig a hole three to four feet deep in the area to be planted. Examine the physical characteristics of the soil, including depth, color, texture, filth, water-retention capacity, drainage, and structure.

Illus. 3-1 Soil Horizons

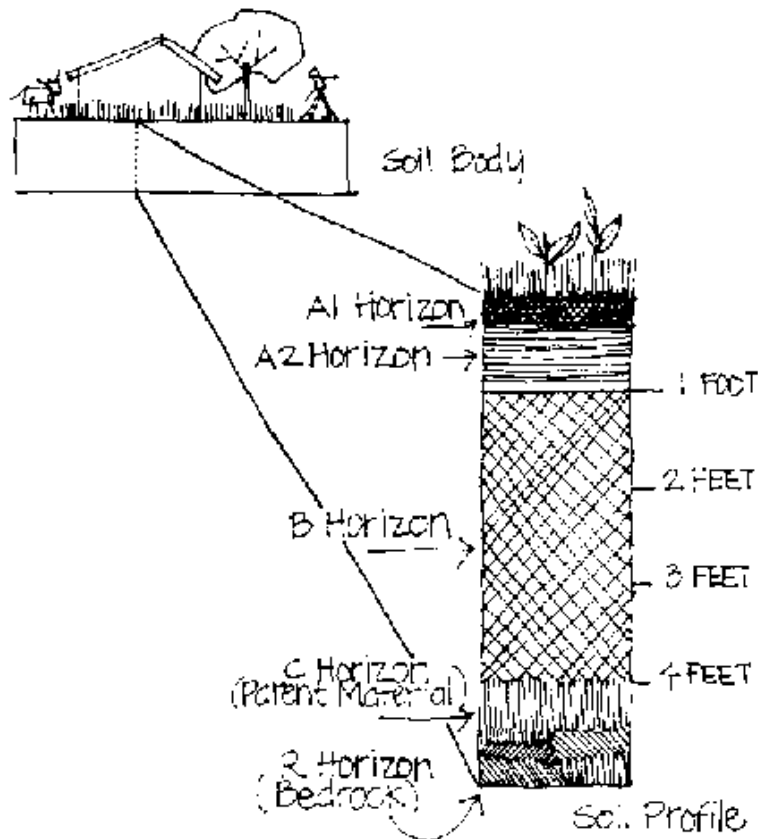

(Foth and Turk, 1972)

The A1, A2, B and C horizon sequence is typical for soils developed under forest vegetation. Also shown is the relationship of soil horizons and profile to the soil body.

**Soil Color.** Color is important to observe and record because it provides information about soil properties. A reddish color, for example, often indicates highly weathered soils with a high proportion of oxidized iron. Gray may be indicative of soils with high, stagnant water tables. Soils in humid areas with a combination of colors (mottled) may have fluctuating water tables, with the mottling spots indicating seasonal conditions of wetness.

Soil color generally changes with moisture content. When judging and recording soil color, care should be taken to avoid such lighting conditions as extreme brightness and low light. Good, consistent lighting conditions are best for testing so that accurate color determination and valid comparisons can be made.

**Soil Texture.** Texture refers to the size and proportion of mineral particles (sand, silt, and clay) of which soil horizons are composed. Texture does not refer to organic matter or humus content. Texture is probably the most important of all soil characteristics, as it dictates **water-retention capacity and drainage properties**, ability to retain and absorb nutrients, and fertility, and thus influences soil productivity and management.

Texture generally varies with soil depth, with the subsoil tending to be more clayey than the topsoil. In order to describe soil texture, the relative proportions of sand, silt, and clay - the mineral components - must be determined. This can be done using "hand" techniques in conjunction with the texture triangle (see Illus. 3- 2).

The three basic texture groups - sands, loams, and clay - can be further subdivided:

<b>SANDS</b> <b>(coarse texture)</b>	<b>LOAMS</b> <b>(medium texture)</b>	<b>CLAYS</b> <b>(fine texture)</b>
Sands	Sandy loams	Sandy clays
Loamy sands	Loams	Silty clays
Gravelly sands	Silt loams	Clays
	Clay loams	Gravelly clays
	Silty clay loams	Stony clays
	Gravelly loams	

**Sand** is made up of loose, single-particle grains, which can be easily seen or felt. Dry sand will fall apart when held in the hand, squeezed, and released. When moist, it will form a mold or cast, but it will crumble apart when touched.

**Sandy loam** is soil with a high content of sand but enough silt and clay to make it somewhat coherent. Again, the individual sand grains can be readily distinguished by sight or feel. Squeezed when dry, sandy loam will form a mold that will easily break apart. When moist, a cast will hold together without breaking if carefully handled.

**Loam** has a relatively balanced mixture of different sand, silt, and clay particles. It is easily manipulated and has a fairly gritty, yet mostly smooth feel. When dry, it forms a cast that will stand up to careful handling. When moist, the cast will not easily fall apart.

**Silt loam** has moderate amounts of fine sand particles and a small amount of clay. It appears lumpy when dry, but the lumps can be easily broken apart into a soft, floury-textured powder. When wet, silt loam easily flows and puddles. It will form strong casts regardless of whether it is wet or dry.

Illus. 3-2. Determination of Soil Classes

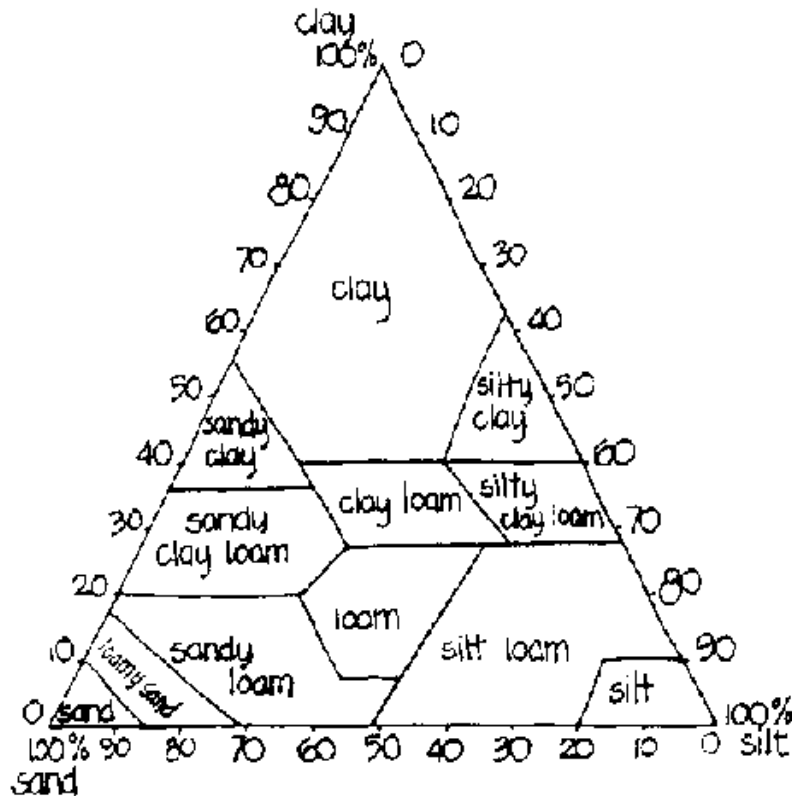

Illus. 3-2. Determination of Soil Classes

(Doneen and Westcott, 1984)

(Doneen and Westcott, 1984)

**Clay loam** is fine-textured, and when moist it has a plastic-like consistency. It breaks into hard clods when dry. When worked in the hand it tends not to crumble but to form a hard, compact mass.

**Clay** is an extremely fine-textured soil that forms very hard clods or lumps when dry and is very plastic and sticky when wet. It can be rolled out between thumb and finger into a worm-like thread. Some tropical clays that are very high in colloids with good aggregation may be workable, but they lack plasticity regardless of moisture content.

Soil texture can readily be determined in the field using simple sight and feel techniques, as described above. It is useful for the community forester to practice these techniques by taking field samples of soils from different locations. (For additional information on soil see "Soils, Crops, and Fertilizer Use," available from ICE.)

The following is a list of general qualities of the different textures of soils. Specific soils may exhibit a combination of these qualities.

**SANDS (coarse soils)**

Pros:	Easily tilled Resist compaction Good drainage and aeration, preventing runoff and erosion Good for root growth
Cons:	Low water-retention capacity Low natural fertility Heavy leaching, due to low clay and humus content and rapid water flow

## LOAMS (medium-textured)

A true loam soil has a combination of the better qualities of both sands and clays. Sandy or clayey loams have some of the negative traits of the corresponding sand or clay soils. In general, however, loams are desirable for cultivation of plants.

## CLAYS (fine-textured)

Pros:	High water-retention capacity, thus more resistant to the effects of drought and leaching Higher negative charge, thus less prone to leaching of positively charged nutrients Higher organic matter content
Cons:	Prone to poor drainage Easily compacted and "sealed," causing impenetrability Difficult to till Tendency to crust over Slow water absorption rate; susceptible to erosion and runoff

When working with small amounts of soil or a small area of land, as in nursery establishment, it is possible to improve soil texture without too much effort. The following are some useful soil improvement measures:

- Add sand to clay, or vice-versa
- Add organic matter, such as compost, animal manure, rotted vegetative matter
- Use mulch
- Avoid compaction of clay soils by keeping people, animals, vehicles and machinery off
- In poorly drained, clay soils, plant on raised beds or ridges
- For sandy soils in dry conditions, plant flat or in the bottom of a furrow to avoid excess water loss

**Tilth.** Tilth refers to the physical condition of soil, how easily it can be worked (tilled), and how well it absorbs water when dry. It can be described as crumbly or cloddy. A soil with poor filth is difficult to work, cloddy, and has poor absorptive capacity. Tilth is affected by other soil characteristics, especially texture, moisture, and organic matter content. Poor filth is usually a problem of clay soils.

Organic matter can improve filth in both clay and sand soils. Large quantities of organic matter applied at frequent intervals are usually required.

Tilling the soil under favorable moisture conditions can improve filth by breaking up clods and loosening soil. Over-tilling, though, can speed up decomposition of organic matter and can compact the soil. Certain crops and intercropping practices may also improve soil filth.

**Soil Structure.** Soil structure describes the arrangement of the soil particles into conglomerates of many sizes. Structure is important because it reflects the processes of soil formation and various aspects of soil behavior, such as infiltration rates, which are important in planning agricultural and forestry schemes. Structure is related to texture and other soil properties. Well-aggregated, crumbly soil is generally desirable, as it allows for good water penetration, aeration, and drainage. Older, more highly weathered soils usually have better-developed structure than younger soils. Soil structure may be enhanced by growing cover crops and adding organic matter such as animal manure or mulch.

If a soil is clayey, wet, and compacted, the pore space will be reduced considerably, resulting in a "puddled" soil. This type of soil is undesirable for planting.

A well-done soil profile description provides a wealth of information-useful to the forestry planner - about the internal and external characteristics of the area under study. Maps showing types and classes of soil located in an area can be compared and used for project planning and siting purposes.

### *Soil Nutrients - Macro and Micro*

Nutrients found in soil, and necessary for plant growth, can be grouped into two categories:

#### **MACRONUTRIENTS**

Primary:	Nitrogen (N) Phosphorus (P) Potassium (K)	Secondary:	Calcium (Ca) Magnesium (Mg) Sulfur (S)
MICRONUTRIENTS			
Primary:	Iron (Fe) Manganese (Mn) Copper (Cu)	Secondary:	Boron (B) Zinc (Zn) Molybdenum (Mo)

Macronutrients make up the most significant portion of plant's diet, up to 99%. Nitrogen, phosphorus, and potassium are the principal nutrients, and those most likely to be deficient in soils. A deficiency in these essentials can be corrected by the addition of commercial or organic fertilizers. Most commercial fertilizers indicate the quantity of N: P: K in ratio form. These essentials are in a less concentrated form in organic additives such as compost.

Although micronutrients are used in much smaller amounts, their presence and availability to plants, even in trace amounts, are essential to plant growth. They are limited in arid sandy soils, muck soils, soils with high pH, and soils intensively cropped and heavily fertilized with macronutrients only. The most common method of correcting micronutrient deficiencies is by adding chemical nutrients. Crop rotation is another method used to correct an imbalance. (For additional information on soil nutrients see, "Properties and Management of Soils in the Tropics." See Chapter 7 for specific information on soil nutrients and improving soil fertility using agroforestry techniques.)

*Problems of Tropical Soils*

Soils found in every region of the world are either acid, neutral, or basic (alkaline). The degree is measured in pH units. pH is important because of its effect on plant yields. The pH scale runs from 1 (maximum acidity) to 14 (maximum alkalinity), but most soils fall in the range of 5.0 to 7.5 or so, with extremes of 4.0 to 9.0. A pH of 7.0 is considered neutral (see Illus. 3-3). Most plants grow best within a pH range of 5.5 to 7.5, although some acid-tolerant plants can stand a slightly lower pH.

The pH of a soil can have an effect on plant yields by influencing the availability of macro- and micro-nutrients. These nutrients are building blocks for sugars and proteins to plants. In the macro environment, phosphorus and magnesium are affected by pH. In the micro environment, the pH level affects the availability of iron, manganese, copper, zinc, and boron.

Illus. 3-3. Soil pH Levels

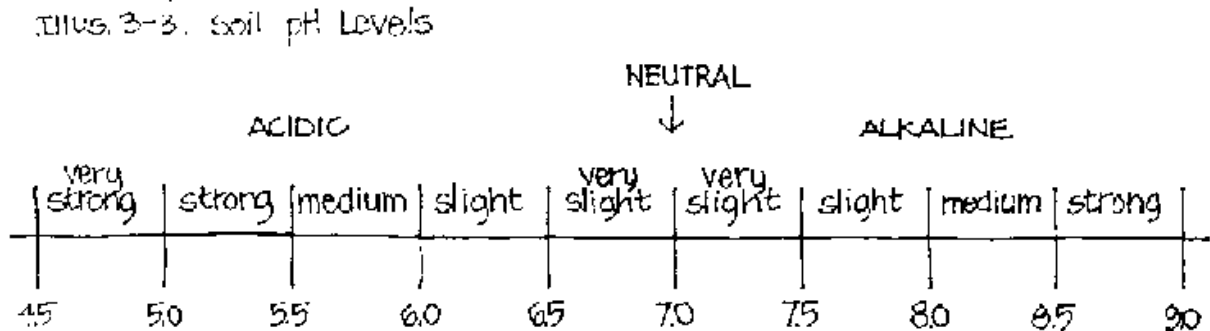

(Leonard, 1980)

(Leonard, 1980)

Problems of tropical soils include macronutrient and micronutrient imbalances, improper balances of salinity and alkalinity, and excessive decomposition (Sanchez, 1976).

**Macronutrient Problems.** The tie-up of phosphorus, a macronutrient, is greatly affected by the pH level. Phosphorus is most available to plants within a pH range of about 6.0 to 7.0. As the pH falls below 6.0, increasing amounts of phosphorus get tied up in insoluble compounds with iron, aluminum, and manganese. Above pH 7.0 phosphorus starts forming insoluble compounds with calcium and magnesium. A phosphorus deficiency can be corrected with the addition of commercial and/or organic fertilizers.

**Micronutrient Problems.** The extent of micronutrient deficiency or toxicity (excess) in tropical soils cannot be generalized. However, wherever soils, particularly acid sandy soils, are prone to leaching, micronutrient deficiencies of iron, manganese, copper, zinc, and boron can be expected. Also, alkaline soils with a pH level of 7.0 or greater have an effect on the availability of iron and manganese. Micronutrient deficiency may be a problem in intensively cropped soils fertilized with macronutrients only.

**Salinity and Alkalinity.** Salinity and alkalinity problems commonly occur in arid or semi-arid regions (with less than 20 inches of rainfall annually), where the water available is insufficient to leach salts from the surface root zone. Salts are released by decomposing rocks and parent material below the subsoil, or they can be brought in by irrigation water on agricultural lands.

In humid areas, rainfall is usually sufficient to wash salts through into deeper soil layers. In irrigated areas, salts will accumulate unless regularly flushed through with high water volumes. High evapotranspiration rates common to drier areas tend to aggravate this problem, especially where subsurface drainage is also poor.

**Saline and alkaline (sodic)** soils are grouped into three classes according to the amount of soluble salts and **adsorbed** sodium (sodium held by clay and humus particles) they contain:

- **Saline soils** contain enough soluble salts to damage plant growth. They can usually be recognized by their surface whiteness, which is caused by accumulated salts. Their pH is generally below 8.5. The usual cause for saline soils is lack of adequate water for leaching or poor drainage.
- **Saline-alkaline soils** contain harmful amounts of both **soluble** salts and **adsorbed sodium**. Although sodium is a very strong base, the pH of these soils is usually under 8.5 because the soluble salts serve as a buffer.
- **Non-saline alkaline (sodic) soils** have low levels of soluble salts but excessive amounts of adsorbed sodium. The pH is high - above 8.5 and often up to 10 - since the amount of soluble salts is insufficient to serve as an effective buffer. The high sodium content results in **poor physical condition** of these soils, which tend to be dispersed and broken down and possibly impervious to water. Both the high pH and sodium levels are harmful to most plants. Sodic soils are also known as **black alkali** soils, as their surfaces are often black due to dispersed humus brought to the surface.

**Harmful Effects of Salinity and Alkalinity.** Soluble salts in soil water reduce plants' ability to absorb water through osmosis. With very high salt concentrations **reverse osmosis**, or movement of water from plant roots back to the soil, may occur, eventually killing the plant. Lower salt levels may cause leaf tip burn, stunting, and defoliation.

Sodium itself may have a toxic effect on plants. In addition, the high alkalinity (pH above 8.5) and presence of toxic bicarbonates in sodic soils are harmful to plant growth.

**Breakdown of Organic Matter.** The higher temperatures common in tropical areas speed the decomposition process - sometimes to the extent that the rate of decomposition may exceed the replacement rate if careful controls are not exercised. Decomposition takes place three times as fast at 90 degrees F as at 60 degrees. This makes "organic" cultivation techniques especially difficult under tropical conditions.

Macro- and micro-nutrient deficiencies, pH levels, and salinity and alkalinity problems are determined by taking soil samples and submitting them to a lab for analysis. A **soil analysis** will tell farmers how many tons of lime and what kind and amount of nitrogen, phosphorus and potassium fertilizers are

needed to correct deficiency problems. Locations of labs are available from the agriculture or forestry extension service.

A one kilo sample - known as the **composite soil sample** - is the only amount of soil the laboratory needs from an area. A kilo of composite soil represents the type of soil in a field. It is collected from 10 different places in a five hectare area. It is important not to collect the samples from areas recently fertilized, as this will skew the results.

With a spade, dig a Y-shape hole 15 centimeters deep. From this hole, take a slice two centimeters thick and five centimeters wide. Take the samples from 10 different places evenly distributed over the field area of up to five hectares. Mix the samples thoroughly and pick out and discard rubbish and other foreign materials. Dry the collected materials in the shade. Do not expose to direct sunlight. (Exposing it to the sun may destroy some of the soil's nutrients.)

Put a kilo of the dried sample in a cloth or plastic bag properly labeled. If the area is 10 hectares, submit two one kilo samples. For deep-rooted plants, take samples from at least 15 to 30 centimeters below the ground surface.

#### *Simple Field Methods for Soil pH Analysis*

Soil pH can be tested directly in the field. When measuring pH, it is important to take separate readings for topsoil and subsoil - they are usually different, and can affect plant growth differently.

A soil sample, mixed well with an equal volume of distilled water or rainwater, can be tested for acidity or alkalinity using any of the following simple methods.

**pH-Indicating Liquids.** These are chemical solutions that react with the soil solution to produce a color which can be matched to a pH color chart. They are easy to use and a kit containing the necessary solutions may be available through the government extension service.

**"Home" Methods.** Highly alkaline soils (high in calcium carbonate content) can be identified using the following method:

Wet the soil sample with a few drops of a weak solution of muriatic acid, vinegar, or lemon or lime juice. If the soil is alkaline, bubbles resulting from the acid reacting with the calcium carbonate will appear.

**Inference or Color Method.** Experienced soil field workers can make relatively accurate estimates of the alkalinity or acidity of certain soils. Yellow or red soil colors generally indicate acidic conditions; the color is due to the high content of iron and aluminum compounds.

Black or dark brown soils with a heavy clay texture are generally neutral to alkaline. Poorly drained soils that are subject to rapid drying during some parts of the year generally have salt accumulations, and are thus alkaline.

**Electronic Methods.** A variety of portable electronic pH meters are available. They are expensive and require some technical skills and training for proper operation; thus they are not recommended for routine field use.

## **4. Project, species, and site selection**

Once the community and the forester have determined community needs and objectives (food production, fuelwood, fodder, etc.) and environmental opportunities and constraints (soil, water, etc.), this information must be synthesized in order to determine the type of reforestation system and select the appropriate species and site(s).

### **Forestry Systems**

There are many types of reforestation systems and species mixes that can fit environmental and/or community needs. If the objective is reforestation for environmental or aesthetic reasons, a project that will interfere as little as possible with natural processes may be planned. On the other hand, a

forester may decide to speed the process along by planting selected species in select locations. The host community may have requested a project that produces usable timber. In this case the forester would suggest a local or introduced species with high market value. In areas with a scarcity of available land, communities may choose projects which integrate a wide variety of products for maximum productivity.

Carefully planned systems can achieve several objectives at once. A project designed to produce firewood can also control erosion, or provide shade and food for livestock. Home gardens integrating trees, vegetables, and livestock can provide necessary daily nutrients for a family, timber for houses, fences, and animal shelters, and even produce a surplus for sale to local markets.

A knowledge of the major differences between natural forests and human-made forests and between native and introduced tree species is helpful in considering which type of project and species should be selected to meet the needs of a particular community. (More information is available in Budowski and Mergen, 1980; Combe, 1982; Fillion and Weeks, 1984; Evans, 1982; Weidelt, 1976; Lamb, 1969; and Spears, 1982.)

### *Natural Forests*

**Natural forests** offer greater ecological stability than human-made forests due to their wider species diversity. They help to maintain and protect watersheds and serve as refuges for wildlife species that add to the diversity of the area. Such forests may also be an important source of food for people and animals. Native plant species are well adapted to limiting factors and local environmental conditions (soil, water, etc.).

While a natural forest cannot be established by artificial means, natural forests may regenerate themselves if given time (and left undisturbed). Natural forest management is the forestry strategy with the least associated ecological damage, and it should be considered where population pressures are not great and the forest can sustain the demands put upon it. However, these conditions are rare in most countries. Population and other pressures tend to overwhelm the reproductive capabilities of a natural forest. Although natural forests are ecologically efficient, their limited ability to produce high-grade species in short rotations makes them less economically efficient than human-made forests or agricultural systems.

### *Agroforests*

**Agroforests** are managed forestry systems designed to produce one or several species of plants for a specific need or market. Specific examples are coffee and fruit farms, timber plantations, or cropping systems that integrate trees with edible plants. Agroforests differ from natural forests in that they are less difficult to establish and harvest, and they are often more acceptable to a community because of their quantifiable returns. Universities, research institutes, and government agencies have conducted extensive research and developed technologies for the establishment and exploitation of agroforests.

Agroforests may have certain advantages over natural forests for communities in need of firewood, marketable goods, and environmental controls. With careful planning, species generally selected for agroforestry systems have the ability to produce one or all of the following results:

- regenerate quickly;
- colonize steep slopes;
- survive in less productive soils;
- improve damaged or marginal soils; and
- produce valuable commodities.

Disadvantages include increased chances of pest and disease infestations when planted in monocultural stands.

Agroforestry systems can incorporate native tree species, introduced species, or a mix of the two. **Native tree species** are those that are found naturally in a particular area. They are already well established in the ecosystem, and their niches in the larger ecosystem are more or less intact. They usually cannot compete with the productivity of introduced species, which are selected for fast growth. Island species are generally least competitive, due to the limited diversity of plant life in island



ecosystems. However, island and mainland species, having evolved and adapted to the environment over a long period of time, may be hardier and more resistant to local pests and diseases.

**Introduced tree species** are imported from another ecosystem. They are generally selected for multiple uses (fuel, fodder, nitrogen-fixing), fast growth for quick economic return, high income value, and ability to succeed on marginal or damaged lands. Some trees have been well studied and tested (e.g., *Leucaena*), and seeds and other germplasm are widely available. One possible disadvantage of particular introduced trees is that their ability to grow fast and survive under adverse conditions allows them to dominate an area. They can outcompete and destroy native trees and food crops in natural forests and on agricultural land. Also, some introduced species may be less resistant to local tree pests and diseases than native species.

Determining the appropriate project, species, and site following an initial inventory of community and environmental needs is an interactive process. Any number of complications can arise when considering the needs and wants of the community, the availability of species, and the availability of sites. For instance, people in an area may desire a particular type of forest project, such as fuelwood or food production, but there may not be species available or adequate sites for nurseries or plantings. Therefore, while choosing and designing a project, it is imperative for the forester and the community to work together to determine species and site availability, site characteristics, and environmental requirements.

### **Project Selection and Design**

Many of the important factors to consider during the project selection process have been covered in Chapters 2 and 3. The type of project selected should fit the needs and resources of the community or individual, and suit the local environment. The specific design will depend on the knowledge of the forester and the technical resources available, including manuals and public information, local people, extension agents, and other sources.

As stated, there are many systems available to a community. One strategy gaining increased popularity in many countries is designed to incorporate **multiple agro-systems** and produce various outputs from the land. These multiple-use projects are effective methods of reforestation and make productive use of the land for the benefit of local people.

Multiple use of a land resource implies proper use and management of the land to produce various types of outputs at the same time. These products may be in competition with each other; the increase in output of one product may decrease the output of others. The products may be complementary, in which case the outputs increase or decrease together. Finally, they may be supplementary; a change in one output has no effect on others. If planned well, community forest projects can include many complementary systems and products that increase the overall productivity of the land and provide numerous benefits from it.

Because of limited resources, many farmers in developing countries are skeptical of systems that devote valuable land to new systems unless they perceive some tangible benefit. For this reason, forestry projects that can be incorporated into existing agricultural systems and provide multiple benefits such as higher family income, erosion control, fuel and fodder, and food will have a better chance of acceptance and full support.

These multiple-use agroforestry systems, involving the interaction of trees with food crops, are complex, interesting systems to establish and manage. They can also be difficult to implement, however, especially within a short time period. They require extensive knowledge of local agricultural practices and conditions and the resources of local farmers, as well as a reasonably good sense of the farmers' desires or abilities to commit those resources to growing trees or multiple crops. However, successful multiple-use programs in many parts of the world have improved the standard of living for local people. For this reason they should be considered the best strategy for a community forester to pursue. Agroforestry techniques and other community forestry strategies are described in more detail in Chapter 7. Basic information about the alternative systems is presented below to assist the community forester in the planning process.

**Agroforestry** is an integration of forestry and agriculture that includes many different strategies of planting. Various systems can be designed to produce products year-round on a sustainable basis. They can increase the productivity of land in many ways. One way is through the incorporation of

**nitrogen-fixing** trees (NFTs), which increase the amount of the nitrogen available to crops. The roots of these trees have nodules in which the nitrogen-fixing bacteria *Rhizobia* grow, if present in the soil. The nodules collect nitrogen from the air which nourish the plant. The nitrogen is in a form that is used by the trees, and much of it ends up in the leaves. When these leaves are collected and mulched around food crops, they act as "green manure," providing the crop with extra nitrogen.

Frequent, high-level application of nitrogen is an expensive necessity for the new, fast-growing varieties of crops common in developing countries today. By providing cheap green manure through the use of NFTs, farmers are able to increase yields with lower costs than those associated with using commercial fertilizers.

The activity of NFT taproots can also increase productivity. Tropical soils are heavily leached of nutrients by strong rains, high temperatures, and exposure to sun. NFT taproots can help recycle these nutrients by drawing them from deep in the soil into their leaves, and thence back through the cycle.

Productivity can also be increased by the protective action of trees. Deep taproots normally associated with NFTs act to stabilize slopes and reduce erosion, thus maintaining the quality of the soil. Agricultural land and watersheds are improved when erosion is controlled, as more water is made available at a more regular rate of flow. The shade provided by trees, even low ones, can control the microclimate so that higher, damaging temperatures are not reached during the day. Trees reduce the effects of wind, preventing drying out and damage to food crops from strong winds. By maintaining the soil, the fourth may be able to carry out sustained agricultural production, reducing the economic pressure that leads people to continue to move onto undamaged natural forest land. Finally, new trees can in time improve damaged and marginal land so that it can be used for agriculture. (For additional information on the role of NFTs in agroforestry systems, see Appendix B. See also "Tropical Legumes: Resources for the Future," available from ICE.)

#### *Types of Agroforestry Systems*

There is no single agroforestry system. Many different systems are in use around the world today, and as the interaction of trees and food crops is better understood, more will be developed. Some of the basic kinds of systems include the following:

- agri-silvicultural systems, which manage land for the production of agricultural crops and forest products
- silvo-pastoral systems, which produce both wood products and livestock
- agri-silvo-pastoral systems, a mixture of the two systems above, which produces tree products, crops, and livestock
- mixed garden systems, which integrate trees, crops, and animals on small plots with the goal of supplying nutrients, materials, and marketable products for a family
- multi-use and production systems, which provide services such as erosion control and watershed recharge while producing forest products and/or crops and livestock.

Other planning options exist. If large areas are available, plantations may be established, but they are expensive to establish and maintain, and their costs usually exceed the means of small communities. If fuelwood is needed, fast-growing trees that coppice well (regenerate new shoots after cutting) can be managed on vacant or marginal land. Fruit trees can be planted where there is a need for more balanced nutrition in the local diet, or if a market for fruit exists. Fruit trees require special techniques and extensive care, however. The rewards of growing fruit trees can be great. Not only do they provide a valuable dietary supplement to the community, but they can also be sold fresh, or processed into juice. Information about the care of fruit trees is presented in Chapter 6.

If no prime space is available for large tree projects in the community, other less used areas can be planted. These include hedgerows, yards, paths and streets, market areas, and steep, unproductive land. In this manner villagers can have easy access to the benefits (food, seeds, shade, fodder, fuelwood, etc.) without having to travel long distances. It may also lead to a greater acceptance and

appreciation of trees and the services they provide, increasing people's awareness of the need for tree conservation.

### **Species Selection**

Selected species must fit the project design, meet the needs of the community, and be able to survive at the available planting sites. Some species may be sown directly; others require nursery propagation techniques.

There are six major factors to consider when choosing a species for a community forest project:

- local ecological conditions
- compatibility with locally preferred food crops (especially for agroforestry projects)
- local customs
- availability of planting stock
- use of tree products
- markets for tree products.

#### *Local Ecological Conditions*

Every potential planting site will have different environmental characteristics. At the same time, each tree species differs in terms of its needs. Trees must therefore be selected so that their requirements are met by the ecological conditions of the area and the site. A good knowledge of the tree's needs and the site's characteristics is required in order to make the optimum selection. The important characteristics of a site should be known before a species is selected. They include the following:

**Soil.** Chapter 3 contains detailed information about soils. Summarized below are key characteristics important for species selection. (For additional information on soils in the tropics see Sanchez, Pedro A., 1976, Properties and Management of Soils in the Tropics.)

**Soil quality** - Good soil allows a forester to pick from a wide range of tree species. Poor soils require the selection of hardier trees that can survive adverse conditions. Important characteristics of soil include texture, depth, chemistry, and moisture.

**Soil texture** - Avoid soils with overly sandy or clayey textures. Soil textures can be improved in confined areas such as nurseries or small planting sites, but over large areas they may be a limiting factor to species selection.

**Soil depth** - Many trees require soil extending to a certain depth; hardier trees (e.g., Casuarina) may be chosen for planting in thin soils.

**Soil chemistry** - Soil pH is probably the most important factor in soil chemistry, as it affects the availability of nutrients and minerals. Limestone soils are alkaline (high pH); badly eroded and heavily leached soils are acidic (low pH). Avoid very acidic soils, which can have high concentrations of certain toxic minerals such as aluminum. Test the soil prior to planting. (See Chapter 3).

**Soil moisture** - The ability of the soil to hold moisture is very important and depends on the structure of the soil. Soils with a high content of humus and clay will hold more moisture than sandy soils. Actual moisture in the soil varies with the intensity and seasonal distribution of rainfall.

**Rainfall.** The amount and intensity of rainfall are important factors when considering species selection. An area may experience high rainfall over the course of a year, but the rain may actually fall in heavy, infrequent downpours and quickly run off without soaking into the soil. Species tolerant to both drought and waterlogging may be necessary. The amount of rain actually captured depends on both the absorptive capacity of the soil and the intensity of the rain. Hard rain produces more runoff, as do large raindrops. The rainfall pattern of the project area should be determined and incorporated into the planning and species selection process.

**Elevation and Temperature.** In the tropics, altitude, temperature and latitude are interrelated. In many areas, the altitude limit of a species is equivalent to the temperature limit. Trees that thrive in or tolerate high temperatures are planted at low elevations, while trees that tolerate low temperatures

are planted at higher elevations. Latitude also affects temperature; in general, the farther away from the equator, the colder it is. Ultimately, this affects the altitude at which a tree can be planted. For instance, at 20 degrees N (the Philippines) *Leucaena* grows to 400 m; at 5 degrees south (Papua New Guinea), to 1200 m.

**Wind.** In many cases, the wind velocity of an area will determine the types of trees that can be successfully planted. Determine seasonal and year-round wind velocities. Using this information, choose appropriate species.

**Fire History.** Avoid sites with a history of frequent fires. If available sites are exposed regularly to fires, choose fire-resistant species and/or use firebreaks extensively.

**Insects, Pests, and Disease.** Some trees are less susceptible to local pests, insects, and diseases than others. Determine the type of pests, period of activity, controlling factors, and the availability of resistant tree species.

**Domesticated Animals.** Consider the positive and negative impacts domesticated animals can have on trees, especially seedlings, when identifying sites and species.

#### *Compatibility with Locally Preferred Food Crops*

Selecting species compatible with local preferences is an important consideration in developing agroforestry systems. People have established preferences for certain foods, based on sociological (what they like, what they are used to) and ecological (what can be grown successfully) considerations. Realistically, a forester cannot expect people to change food crops to accommodate trees, thus the species selected must be compatible with locally cultivated food crops.

To determine a tree's compatibility with locally preferred food crops, the demands of that crop, such as light, water, temperature, and nutrients, must be known.

**Light.** The tree species selected should reflect the fact that plants demand different intensities of light. In other words, shade-intolerant plants will not grow well under trees with dense canopies. For instance, rice demands long hours of daylight, so trees with thin canopies should be planted along the edge of the field (see Illus. 4-1). On the other hand, plants that demand a certain amount of shade, such as coffee and cacao, should be planted under shade trees (see Illus. 4-2). Spacing of trees can also be calculated to fit light requirements.

Illus. 4-1. Shade Intolerant

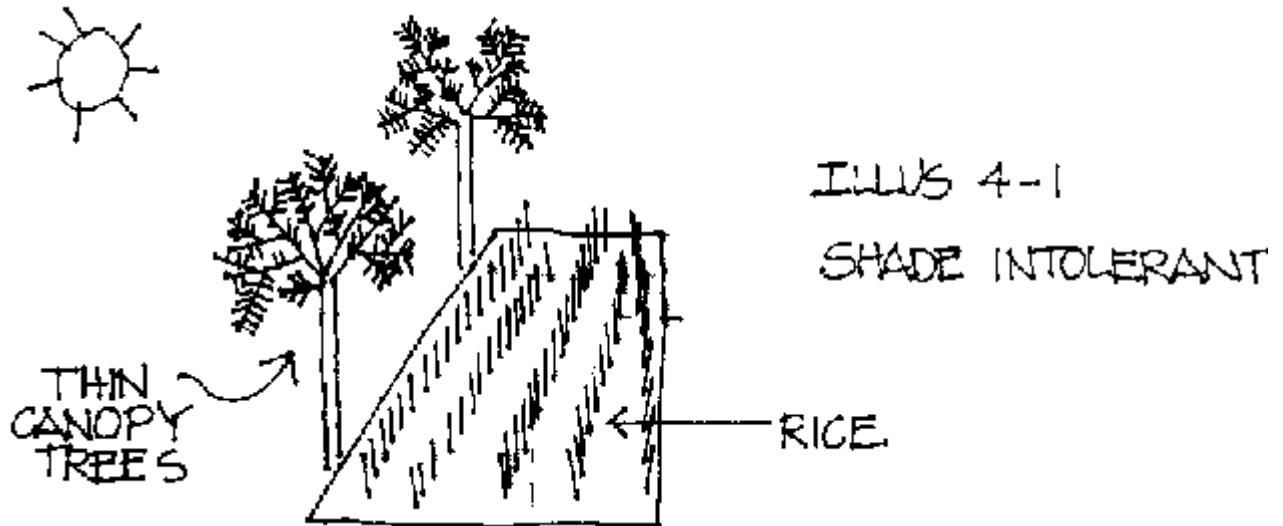

Illus. 4-2. Shade Tolerant

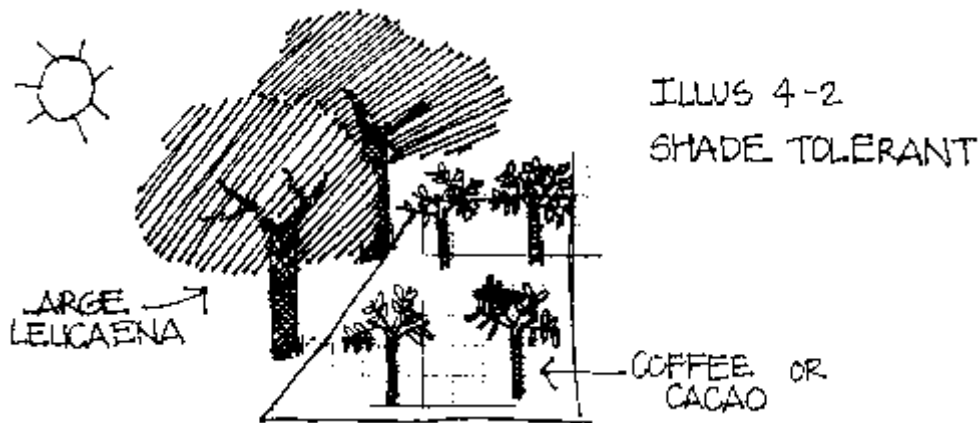

**Water.** Tree species with deep taproots should be integrated with annual crops in order to conserve water. The tree will use deep water, reserving water in the top layer of soil for the annuals. Consider the water requirements of crops and trees during wet and dry seasons, and especially during planting time.

**Temperature.** Trees can be used to lower the ground-level temperature during the day (by shading), or to maintain higher temperatures during the night, as in any natural forest. Shading is helpful for heat-sensitive crops, and especially helpful for protecting livestock from overheating during the day and losing too much heat at night.

**Nutrients.** The nutrient requirements of crops can be partially supplied by trees that fix nitrogen. These nitrogen-fixing trees recycle other nutrients that leach into the lower soil levels through the activity of their taproots. The nutrients then migrate into the leaves along with nitrogen. Leucaena, Calliandra, and Casuarina are examples of trees that fix nitrogen and have deep taproots that are instrumental in recycling nutrients. The strategies to employ when using these trees, along with their specific characteristics, are covered in Chapter 7 and in the appendices of this manual.

#### *Local Customs*

After people's needs and wants, the most important factor to consider is the traditional use of the land being considered for a project. If people have traditionally raised or stockaded animals in the area, then trees will have to be protected and/or unpalatable trees will have to be selected. It is also important to consider what trees are attractive to and highly valued by people.

#### *Availability of Planting Stock*

The availability of planting stock will determine to a large extent which trees can be considered. Viable seeds and hardy planting stock must be collected early for successful and timely planting. One option is to order specific tree seeds from reputable suppliers. This may take a long time, as suppliers may be located in other countries, thus involving lengthy transport and customs procedures. A better option is to identify seed suppliers in country, such as missionaries, aid organizations, and government forestry and extension services.

#### *Use of Tree Products*

Trees must be selected to fit local demands. Local demand may be for fuelwood, poles for simple construction, fodder, erosion control, and nitrogen for cultivation. These needs should be identified before a species is selected.

For fuelwood demands, select trees that are straight-grained for easy splitting, hard so that logs burn slowly, easy to ignite, and productive of minimal smoke. Wood that produces long-burning charcoal is also advantageous. Trees that coppice, or resprout shoots after cutting, are preferred, since replanting is not necessary. Calliandra and Leucaena meet all of these requirements.

Fodder for animals requires trees with palatable leaves that regenerate rapidly. The leaves should be nutritious and should not cause adverse effects on the animals. Calliandra and Leucaena are good fodder trees, although it has been reported that overconsumption of Leucaena leaves can cause hair loss and goiter in animals. For this reason, Leucaena-fed livestock should receive dietary supplements.

Trees with deep taproots are an especially effective method to control erosion. When planted along contours and interspaced with rows of crops, they act as a buttress against eroding soil, and in some cases supply nutrients to the soil. Choose hardy trees that can be pruned low to the ground so as not to shade food crops. Leucaena and Calliandra both function well for this purpose.

Nitrogen is one of the major limiting factors to crop production. As previously mentioned, many trees fix nitrogen through the action of Rhizobia bacteria present in the soil and working symbiotically with root nodules. The leaves of these trees, where much of the nitrogen ends up, can be used as mulch to augment the fertilizer needs of farmers and/or reduce their fertilizer costs. This "green manure" approach is a major selling point for the use of trees in agricultural systems.

#### *Markets for Tree Products*

One of the major impediments to the acceptance of agroforestry systems designed to produce marketable items is the difficulty in securing long-term markets for a wide range of products. Traditionally, markets for fuelwood and charcoal, poles, pulpwood, and sawn timber have been strong. These products are less of a risk to the farmer because they require minimal investment, since they are secured from existing forests. Markets for other products such as fodder, fruit, and food crops are more risky. They require a higher investment in terms of time and money. They must often be marketed locally due to high shipping costs and low market value.

One method of avoiding marketing problems is to form a **marketing cooperative**. The larger volumes of goods associated with collective marketing can lower transportation costs and bring higher prices. Cooperative members can also influence market prices by controlling the supply sold to a buyer. Frequently, when large amounts of products are dumped on the market, prices drop. Cooperatives can monitor prices and sell when profitable.

#### **Site Selection**

Site selection should be a thorough, careful procedure. The two major types of sites to consider are nursery and planting sites. Some projects require both types of sites. For direct seeding projects, a nursery is not required.

#### *Nursery Sites*

Nursery sites should be centrally located and accessible to the planting sites. Adequate water is a high priority. Proximity to roads and quick transport is important, as prolonged exposure of seedlings and cuttings during transport must be avoided. It is a good idea to locate the nursery near a settled

area so that it can be constantly supervised and maintained regularly. If pots are to be used for seedlings, soil can be prepared at the site and placed in the pots as needed. If cuttings are to be transplanted directly into the soil, the soil must be of high quality, rich and deep with good drainage. A soil with a crumbly texture is best, with a reasonable mix of sand and clay. Other points to consider are:

- The availability of local labor and materials for constructing fencing, sheds, etc.
- The need for protection from wind, animals, and people,
- Written permission from the owner of the land or the community for its use
- The need for a caretaker
- Sites with few weeds
- Sites not recently used as nurseries (to avoid pests and depleted soil)
- Sufficient size for the expected need, with extra room adjacent to the facility for possible expansion.

Many of these points are covered in detail in Chapter 5. (For more information, see FAO, 1977; FAO, 1980; and FAO, 1982.)

### *Planting Sites*

Planting sites require the forester to learn land use patterns and analyze environmental opportunities and constraints in the area. These factors will determine if trees are needed, where they are needed, and how they can best be used. The most common reasons for planting trees fall into two categories: protection/conservation and production.

For **protection/conservation** purposes, select a site that provides the best possible conservation results. Marginal lands or lands damaged by erosion can be greatly improved by tree planting. The site conditions will largely determine the types of tree species selected.

For **production** (food, fodder, fuel, etc.) a good site is necessary to maximize output. If farmers' fields are to be used, trees that work well with existing crops must be planted. Markets and transportation should be available on a regular basis. For forestry and community development purposes, using marginal and damaged land for production will allow both production and protection. There may be a need for both production and protection where ideal sites are not available for the type of trees specified by community and environmental needs.

As stated before, the community must be involved in the process of site selection. Other considerations involve permission (written) from the owner(s), agreements for maintenance and protection, and agreement on the techniques to be used.

## **5. Nursery development and practice**

Developing a nursery is necessary under several conditions:

- When no nursery is within easy traveling distance;
- When there are no outside sources of seedlings; and
- When the species cannot be directly sown.

Travel time is an important consideration in determining the need for a nursery. If it is necessary to travel several hours from the nearest nursery to the planting site, the excessive travel time may result in death or poor growth of the seedling due to lack of moisture and shock. If there are no government programs or commercial nurseries to supply the desired quantity or species, it may be advantageous to establish a large nursery that supplies products region wide. In some cases, it is necessary to start a nursery because the species chosen requires special care prior to transplanting to the field.

The type of nursery is determined by the scope of the project. If the objective is to provide seedlings on an ongoing basis for various projects, or individual home plantings, it is necessary to develop a **large, centrally located facility** with a wide variety of plants. This type of nursery should be self-sustaining, or maintained by government funds. If the objective of the project is to provide trees for one small individual project, a **temporary facility** should be developed. As the project concludes, the site can be used for another purpose. Whenever possible, local materials, labor, and other resources

and appropriate technologies should be used. The amount of land to be used depends on the size of the project, its goals, and the availability of land in general.

For more information on nursery development and practice, see Fillion and Weeks, 1984; ICE Manual FC06; Evans, 1982; Elliott and James, 1982; FAO, 1977; Jordan and Farnworth, 1982; and Wadsworth and Mergen, 1980.

### Major Considerations

#### Materials

Purchase the necessary nursery materials (fencing, construction material, tools, pots, plastic potting bags, etc.) well in advance of the planned start-up date. Early purchase of materials will avoid delays in planting or transplanting. Costs may be reduced and local acceptance increased by the use of local materials and labor and the integration of local knowledge into the design and construction work. Materials not available locally can normally be acquired from government forestry offices or agricultural suppliers.

A list of materials could include the following: plow, hoe, rented draft animal or hand tractor, shovels, budding knife, pruning shears, pruning saw, pots (plastic bags, bamboo, clay), plastic sheets, spade, wood or wire fencing, construction materials for a shed, watering cans or hose, soil, sand, compost, and 55-gallon drums. (See Illus. 5-1.)

Illus. 5-1. Nursery Tools

Illus. 5-1 Nursery Tools

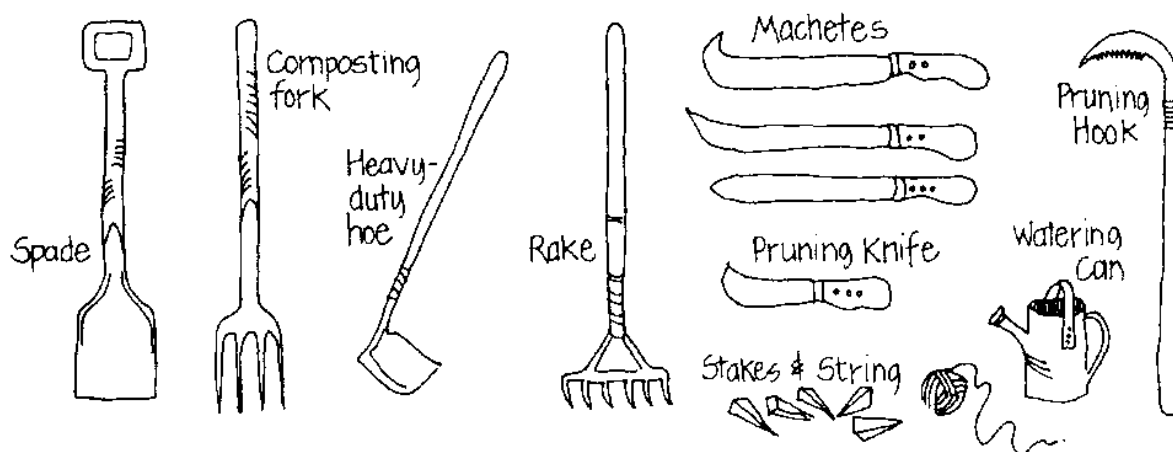

#### Timing

Timing is a critical factor in nursery development. Timing issues include the amount of time needed to set up, acquire materials, and make sure seedlings are ready for planting at the right time of year. An additional timing consideration is arranging labor and transportation for critical times (planting of seeds or stock, transplanting to planting sites, etc.). This planning should be done well in advance, since labor may be in short supply when workers are needed for other farming activities.

The most important time consideration is the timely planting of the seedlings. Since the survival chances of young trees depends directly on the maturity and size of the trees when transplanted, and upon transplanting at the right time of year, the timing of the project must be carefully planned.

The timing involved in seeding or placing open rooted stock or vegetatively propagated plants in the nursery must therefore be carefully considered in order to ensure that planting stock is ready at the correct time. Planting too late in the nursery will make for immature seedlings with lessened chances for survival.

Conversely, planting too early in the nursery will produce heavier seedlings that will be harder to move and transplant, and may become pot-bound.



To time the planting, the forester must know how long each species must remain in the nursery and plan nursery time to coincide with the rainy season. For the recommended age of transplanting for species covered in this manual, see Appendix C. Further information is available from the government extension service and agricultural schools.

Other planting considerations that must be taken into account are the overall location of the nursery, soil, sunlight, and local climate. All of these can speed up or slow down the development of seedlings. To avoid having a project ruined by these factors, it is necessary to consult local experts and records of other projects. It is important to keep good records - for yourself and for those who follow.

As stated, long-range planning is crucial for successful nursery operations. It avoids shortages, waste, and lost opportunities. Along with materials, record-keeping, and timing, other considerations for nursery development include soil, water, labor, space, design and layout, light and shade, protection and maintenance, propagation methods, care of nursery plants, records, and other activities.

### Soil

Good, rich soil promotes healthy development of seedlings. Before a nursery is established, the soil should be tested for its suitability with the trees to be used. Factors to be tested for include pH, nutrients (nitrogen, phosphorus, others), and overall composition. (For more information on soil fertility, see Tisdale and Nelson, 1975.)

Adjust the soil according to the needs of the plants, if possible. Adequate fertilization is especially important to open-rooted stock. For open-rooted stock, cultivate the nursery soil to the expected depth of the roots. Add nutrients and any other elements the soil is lacking at this point.

Nutrient -rich soil should be developed for nursery use by the mixing of compost (see Appendix D), sand, and soil. A standard mix is 1/3 sand or loose soil, 1/3 clay, and 1/3 compost (see Illus. 5-2). This soil is loaded into pots or plastic bags, or used to make nursery beds. When planting in beds, it is necessary to supplement the soil mixture with additional nutrients: add a generous amount of composted animal and plant debris. A general rule is 90 kg per hectare. Continual addition of compost will ensure good soil structure.

Illus. 5-2. Soil Mix

### ILLUS. 5-2. SOIL MIX

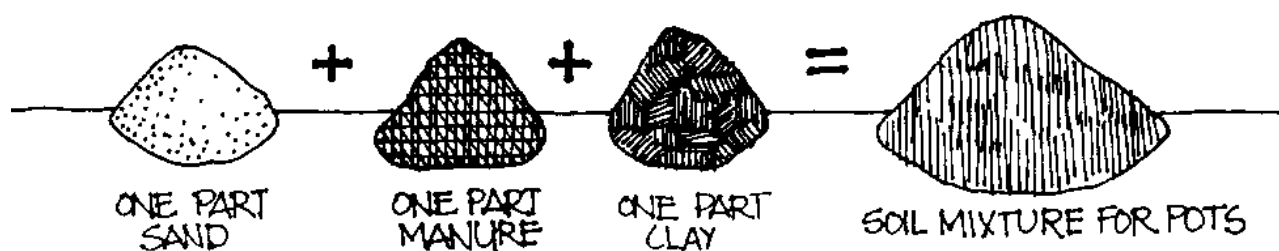

Inorganic commercial fertilizer can be used to improve the fertility of the planting medium. However, it is expensive and may not be available. Where it is available, add commercial fertilizer containing nitrogen and phosphorus to the soil, clay, and compost mixture during preparation, or after placing the soil in the pots, plastic bags, or beds. (For additional information on the use of commercial fertilizers, see the Western Fertilizer Handbook written by the Soil Improvement Committee, California Fertilizer Association, available from ICE.)

It is very important not to leave the soil exposed to the sun, rain, and heat of the tropics for very long, as all of these elements will deteriorate the quality of the soil. Sunlight will bake the soil, dry it out expose it to wind erosion, and kill exposed microorganisms important to plants, such as mycorrhizae. Rain will leach out important nutrients and, if sufficiently strong, will wash away precious soil. Tropical heat speeds oxidative reactions in the soil, further weakening the soil's ability to nurture seedlings. Protect soil at all times, especially after tilling, by mulching with grass cuttings.

## Water

The cost, quantity and amount of water are important considerations in the development of the nursery. Projects can be seriously hampered if source of water becomes polluted, dries up, or is diverted for another project. To ensure the financial and technical feasibility of the nursery, the forester must assure that adequate quantities of clean water are available at a reasonable cost.

Different water quality levels will determine the uses and species that can be successfully used. Drinking quality is not necessary for plants, although a drinking supply should be allotted for workers (unsafe water will cause sickness and absenteeism, which can disrupt the schedule). Overly dirty or organic water should be avoided or filtered, as slimes will gum up nozzles and valves.

The most important considerations when locating a water supply are the salt content and hardness. Water hardness is the result of excess minerals in the local groundwater. If hard water is used for long periods, the pH of the nursery soil tends to rise (become alkaline). If water is so hard that this cannot be avoided, then rainwater may have to be collected. This will require rainwater catchments and storage facilities, which must be incorporated into planning (along with considering rainfall patterns and supply).

Although some plants are tolerant of low levels of salt in water, most species will die if exposed to high concentrations. Even low levels of salt can be detrimental to seedling development in some species. Salt can come from many sources, including wells and surface water. Salt may have accumulated in ponds that previously evaporated away, making them unusable for water storage.

A shortage of water is a serious problem that adds to salt crystal development. For sites with limited water, use water sparingly. Occasionally flush seedlings with large amounts of water to remove as much salt as possible. This over-irrigation is one solution, although it may also leach nutrients out of the soil. If the needs of the community are compatible, salt-resistant trees such as *Casuarina* may be grown where no method of reducing salt exists. There are salt levels so high that no trees will grow. If this is the case then a different site should be chosen for the nursery. See Appendix C for salt-tolerant species.

While planning the nursery, it is important to calculate how much water will be needed on a daily basis. This will determine all water supply plans and activities. Once the daily amount is known, it is possible to determine the pumping rates and water storage needs for the nursery.

An easy and reasonably good method for determining daily needs is to measure the area to be watered (the planting beds) and multiply this by 0.02 m. This will give the amount of water in cubic meters to cover the area with a sheet of water two centimeters in height. For example, if a bed is 1 m  $\times$  5 m, the amount of water needed per day will be: 1 m  $\times$  5 m  $\times$  0.02 m = 0.1 cubic meters, or 100 liters of water. (See Illus. 5 - 3.)

Illus. 5-3. Water Need Calculation

### ILLUS. 5-3. Water Need Calculation

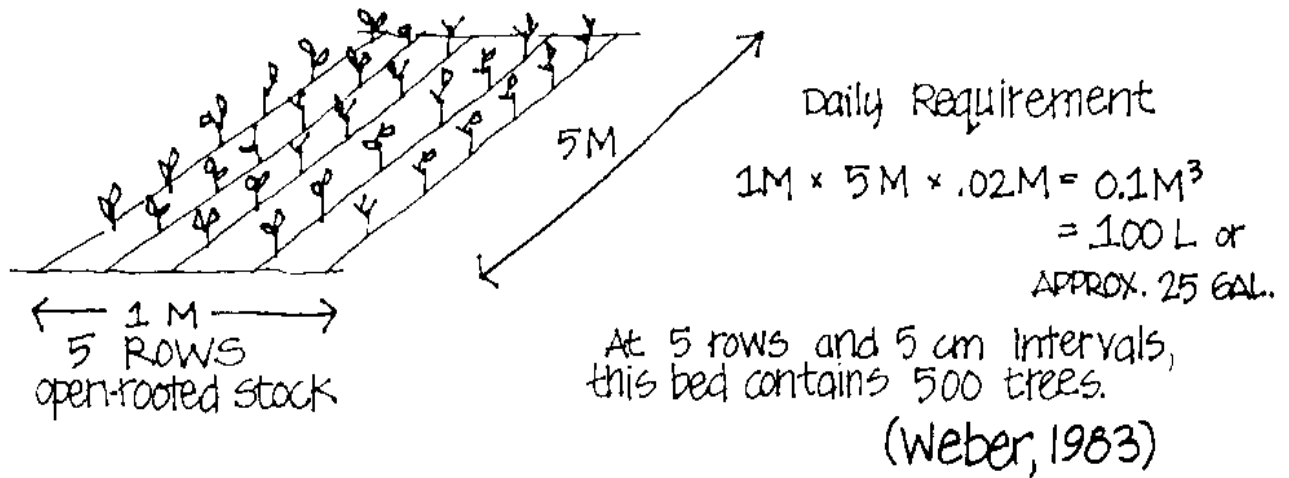

If the nursery has ten beds, it will require 1000 liters of water a day. This means the nursery will need 365,000 liters of water a year, if it is producing seedlings on a continual basis. Fluctuations in this number will occur depending on number of beds in production and maturity of the seedlings.

This calculation should show the amount of water adequate for most trees under most conditions. It can be less if:

- There is adequate humidity, shade, and protection from wind;
- Available water is used during the cooler parts of the day; and
- There is good water retention in the soil.

Under these circumstances, it might be possible to reduce water needs by up to one half. Other strategies to conserve water include sinking the pots in the ground, mulching, and constructing shade devices.

Water can become a limiting factor to nursery development. It may be necessary to carry out ground, surface, and rainwater schemes to assure an adequate supply. (For additional information on methods of collecting or extracting water, see ICE publication "Appropriate Technology in Developing Countries." The bibliography lists other sources of information for these types of projects.)

#### *Labor*

Labor requirements are extremely variable and depend on methods used, species, and sites. A large, permanent nursery requires more initial preparation and long-term maintenance than a temporary nursery. This means a large work force is needed for site preparation, and small staff for continual maintenance. Usually a wider variety of species are cultivated in a permanent nursery, which requires additional labor and a more knowledgeable work force.

Labor needs are not as great for a temporary facility. It is advantageous to site the facility near the project site, yet as close to the beneficiaries as possible. By placing the facility near a residence, it is possible to provide 24-hour surveillance, and better yet, a caretaker.

Regardless of the type of nursery, sites located on marginal lands need many days of laborious preparation in order to clear trees, rocks, and work the soil.

It is possible to calculate labor needs by referring to previous records of similar jobs and consulting local experts. Plan ahead to ensure that an adequate workforce is available at critical times. Whenever possible, use local volunteer labor to assist in the early phases of construction. Periodically, request their assistance to perform general maintenance such as weeding and general construction activities. Hold training sessions on the same day so the participants can take some knowledge home with them. If you are applying for a grant, many organizations will require the

beneficiaries to contribute some form of assistance, whether it be money or labor. However, make it perfectly clear to the participants that they are volunteering. Too many foresters have found themselves without a labor force once workers realized there was no pay.

If the nursery is permanent, provide enough money in the budget for a full-time live-in worker. One way to ensure high-quality work, as well as ensure the continuity of the project, is to recruit a recent graduate from an agricultural school to assist in managing the project. Enroll the manager in a short training program with the national extension service. It may be possible to make an arrangement in which the manager spends several weeks at a government nursery assisting in daily operations.

### Space

Space considerations are determined by the needs of the plants and the community, how much time and money is available, and how easy it will be to acquire written consent and permission for use of the land. Consider sites that allow expansion if extra room is likely to be needed or desired.

Estimating the Amount of Space Needed. First, the number of trees required by the project is determined by considering the overall project design and the capabilities and needs of the community. After determining numbers, the total space for the nursery can be calculated. As a general rule, when estimating the area needed for a nursery, use the following guidelines: for open-rooted stock, 1,000 trees need 10 square meters of space; for potted stock, 1,000 trees need 7 square meters of space. (See Illus. 5-4.)

Illus. 5-4. Planning Nursery Beds

### Illus. 5-4. Planning Nursery Beds

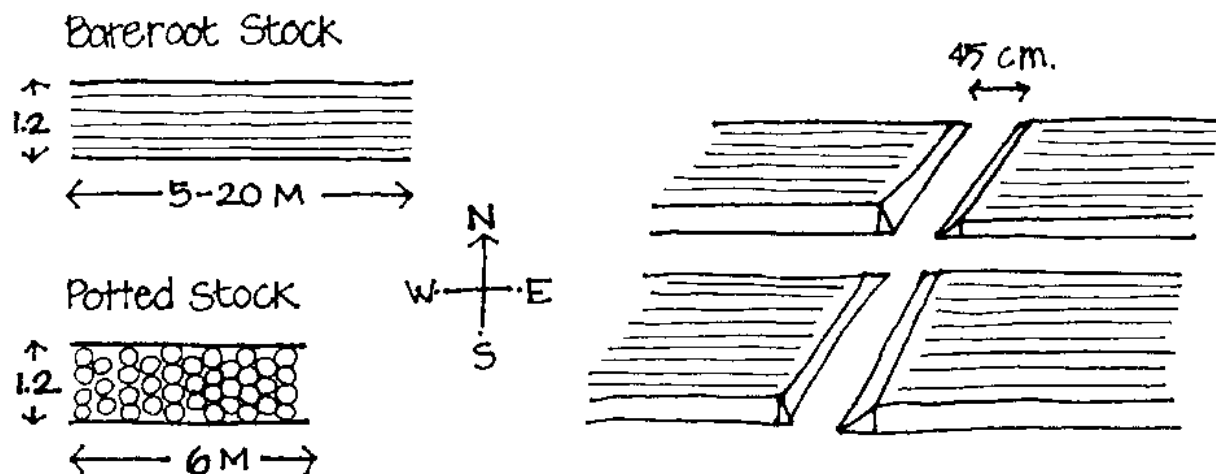

After calculating the area, add 15-25% of the above figure to account for the miscellaneous needs of the nursery, such as extra nursery beds, walkways, roads, work sheds, firebreaks, and research areas. It may be tempting to add even more space, but doing so will add to the overall cost of the nursery because additional fencing, maintenance, and other items will be necessary.

A sample calculation to estimate the amount of space needed would take the following form:

A community forester decides that 800 *Leucaena* trees per year would best suit the community's needs, resources, and capabilities. Pots are not locally available, but a good site with good loose soil is available and will be suitable for open-rooted stock.

For 800 trees, using the open-rooted method, the initial calculation is  $800 \times 10 \text{ sq. m} = 8,000 \text{ sq. meters}$ ; added to this figure is 15-25%;  $8,000 \text{ sq. m} \times 0.15 = 1,200 \text{ sq. meters}$ , or 9,200 sq. m total,  $8,000 \text{ sq. m} \times 0.25 = 2,000 \text{ sq. meters}$ , or 10,000 sq. m. total. The size of the nursery should range between 9,200 and 10,000 square meters.

### Nursery Design and Preparation

Good design and preparation will increase the efficiency and productivity of a nursery operation. Unnecessary deaths of seedlings can thus be avoided, which is crucial when a project requires a specified number of trees in order to be economically efficient.

Nursery design depends on the site. Some general guidelines exist that can help in the initial stages. Draw out your design so that the best overall nursery plan can be developed, and so that alternative plans can be easily formulated. (See Illus. 5 - S.)

The size, orientation, and location of the nursery beds are important considerations. Beds should be 1.2 m in width for ease of weeding; their length will depend on the shape of the nursery. Orient the beds with the long dimension of the bed running from east to west. This orientation allows even exposure throughout the day for the trees on both the inside and outside of the bed. If the area is level create a slight slope to facilitate surface runoff.

The beds should be separated by walkways that are at least 45 cm wide, allowing people with wheelbarrows easy access for weeding, pruning, and other treatment. Beds should be slightly raised above the walkways, at least 15-20 cm. This allows good root penetration and easy maintenance. A slightly concave shape is recommended for the top of the bed. This controls erosion of the sides and enhances water retention.

If the nursery is permanent and the budget allows, lay a concrete pad as a base for each of the beds. The pad will deter roots from penetrating too deeply, as well as facilitate surface runoff. Another option is to line the bottom of the beds with plastic sheets. Large fruit tree plantations use plastic bags to cover the fruit during crucial periods. When split they make excellent liners, and plantation managers are often willing to provide them free of charge. (See Illus. 5-6.)

Illus. 5-5. Nursery Design

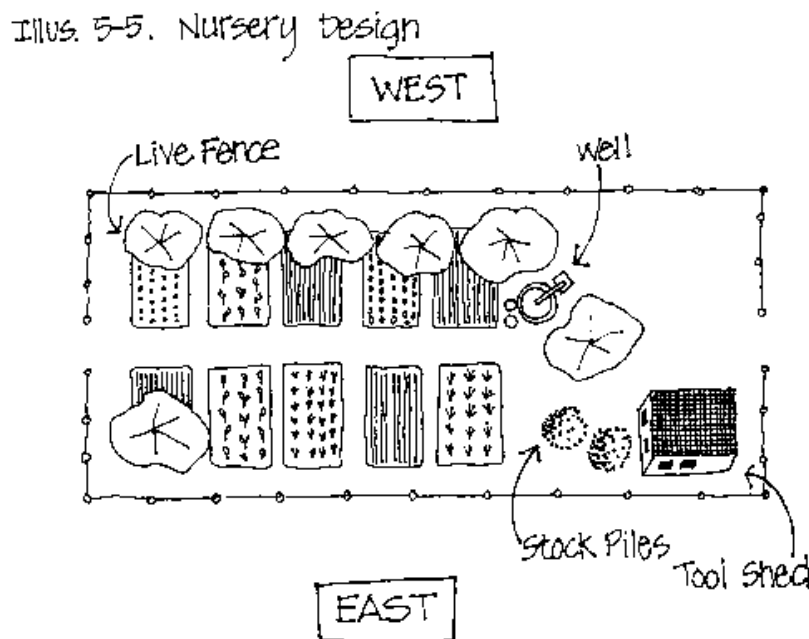

Illus. 5-6. Planting Bed

Illus. 5-6. Planting Bed

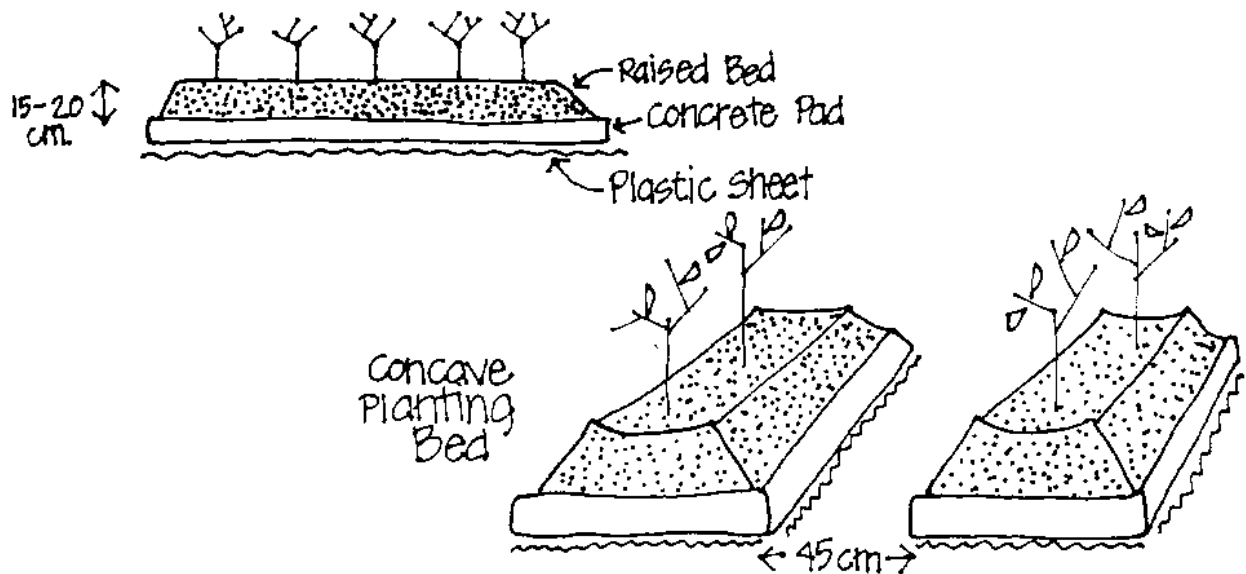

Space should be made available for a driveway and turnaround so that trucks, tractors, and carts can drive right up to each bed. This access will avoid long carries and allow quick loading of seedlings for transport. Other items to work into the design include supervisor's quarters on the site, a work and storage shed, a soil compost pile, a water supply or well, a research area, and germinating beds. The space allotted to each of these will depend on their importance to the project, their size and the size of the project, and on the availability of space. Another important item needed is a firebreak surrounding the entire nursery. This should be 3-4 meters wide to prevent nearby bush fires from destroying seedlings. The firebreak should be wider in fire-prone areas.

#### *Light and Shade*

Seedlings tend to be fragile following sprouting and transplanting. This is due to the immaturity of the root system, which is unable to support the seedling during times of stress. The harsh tropical sunlight can be a serious threat to these young plants. On the other hand, seedlings require increased light as they mature in order to maximize the rate of growth. For this reason, it is best to pick a site with both shade and open areas. Protect the seedlings until they are hardier, and then move them into direct sunlight. A site with carefully placed shade trees is a good idea, although too much shade will slow the growth of seedlings, (See Illus. 5-7.) It may be possible to thin out tree cover, but no large sections of tree should be cut out if the objective of the nursery is tree conservation.

If no trees exist, shading for young seedlings may have to be constructed, especially in hot, dry areas. Use local resources, materials, and labor for the reasons listed above. Spread raised woven mats and banana and other leaves across seedlings as shading. (See Illus. 5-8.) Prior to planting, sow fast-growing tree species around the perimeter of the site.

As an intermediate step between shading and full sun, seedlings in pots can be half-buried in trenches dug in the shape of nursery beds. This step limits the amount of water lost - the major form of stress caused by excess sun - yet allows full exposure to the sun much earlier, for faster growth. (See Illus. 5 - 9.)

#### *Protection and Maintenance*

Besides drying out, harsh sun, and the dangers to seedling growth cited above, other problems exist of which nursery managers must be aware. These include dangers from livestock, people, pests, and fires.

Seedlings have no chance for survival if they are trampled on or eaten by livestock. To protect the area from livestock, 24-hour surveillance or fencing is required. This may not seem to be so important where few livestock roam, but it may only take several animals to wipe out months of work. A combination of fencing and surveillance may be necessary if other problems include theft and pedestrian traffic.

**Illus. 5-7. Beneath Shade Tree**

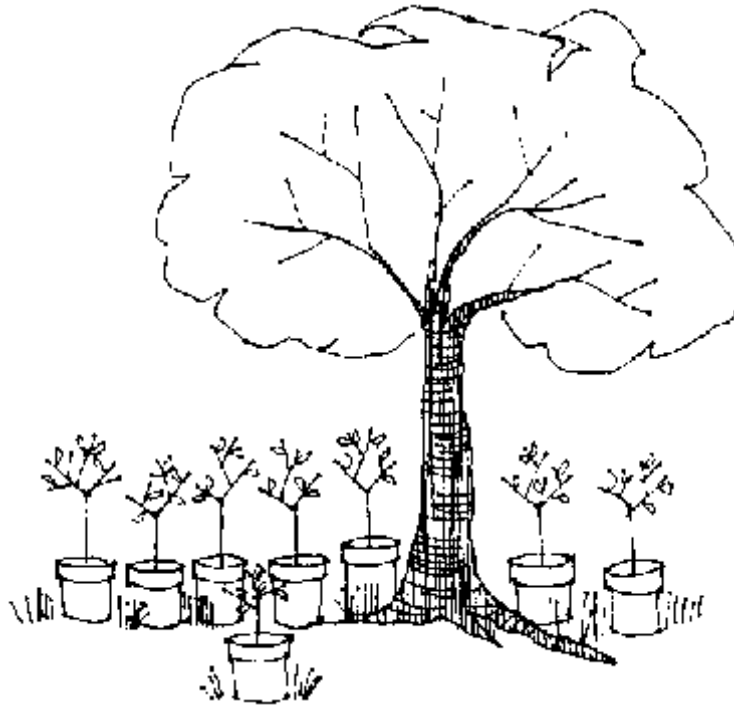

**Illus. 5-8. Shading**



**Illus. 5-9. Sinking Pots**

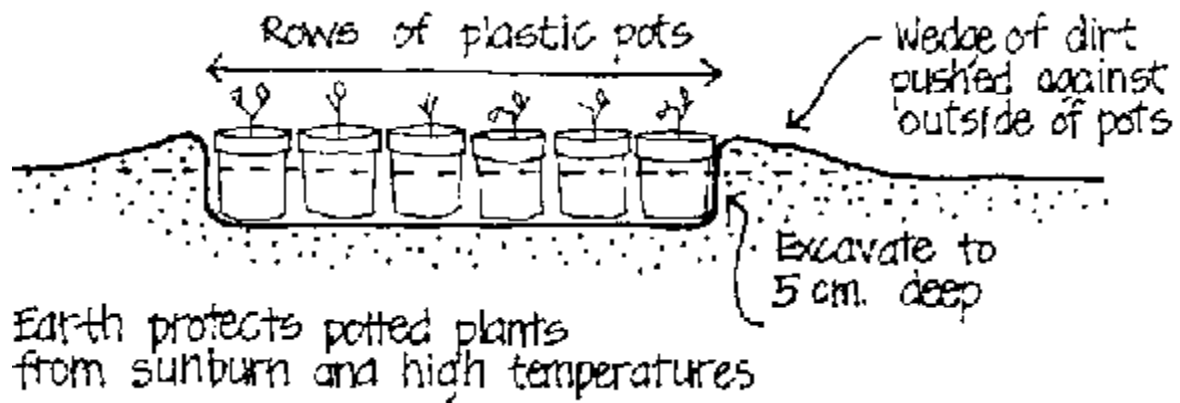

For **surveillance**, people must be available and willing to work regularly. In the case of a permanent nursery, a worker may be willing to live at the site. The cost of paying workers must be considered, as it is unrealistic to hope that people will volunteer to watch the nursery for the entire time it will be operating. Food, money, shelter with land, or any other locally acceptable form of payment should be used.

**Fencing** is the best alternative to hiring a full time worker. The type of fencing used will depend on availability and purchase and construction costs. Cost and availability are usually linked: the cost of the fencing often depends on the type of material available.

Before deciding on the type of fencing, determine the local land use patterns. Be aware that fences may cut off a walkway or traditional grazing area of which you are unaware. Plan around customs, and ensure that change will not adversely affect area residents.

Local materials may be used entirely or in part to save money. Bamboo, wood stakes, layered branches from thorn trees, and other structurally sound materials are adequate assuming they are maintained regularly. (See "Appropriate Building Materials" by Roland Stulz, and "Tools for Agriculture: A Buyer's Guide to Low Cost Agricultural Implements" by John Boyd, available through ICE.) Another option is to purchase wire fencing from an agricultural supply store. A live fence, which can provide fertilizer, seed, and rooting stock, is also viable if there is sufficient time to wait for the trees to mature. (See Illus. 5-10 for examples of fencing materials and Appendix C for species that have been used as live fences.)

Illus. 5-10



## ILLUS 5-10 FENCING MATERIALS

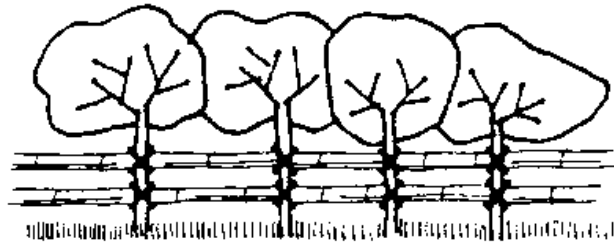

LIVE FENCE



BAMBOO FENCE



BAMBOO OR STICK STAKES



METAL FENCE

Design the fence to keep out all types of animals. Several wires strung four feet ok the ground may keep out large animals such as cattle and mature pigs, but it will not deter piglets or chickens. It is necessary to add thick brush or additional wire at the base of the fence to keep out piglets. Chickens are almost impossible to discourage if it is not a local practice to clip wings at birth. In this case only surveillance will work.

Construction costs are another consideration in the type of fencing to be used. A wire fence or fence constructed from local materials requires digging holes and setting posts. A live fence is easier to install, as all it takes is shallow plowing, planting, and periodic maintenance. Whenever possible, train and use local volunteer labor in fence construction.

**Maintenance** is an absolute necessity for fences, and its cost must be considered. Without maintenance, the fence might as well not be erected, for it will soon come down. Maintenance will be especially important when fragile items such as twigs and sticks are interwoven into the fencing to keep smaller animals out. Without constant monitoring, they will eventually work loose and fall out.

**Fire** can ruin a nursery in short order. Check sites for history of fire. Know the dry season months and plan accordingly. Encircle the nursery with a firebreak, and conduct regular patrols to prevent build-up of materials that will allow the fire to pass into the nursery. If available, water should be kept on hand during dry periods to fight any small, controllable outbreaks.

**Wind** can dry seedlings out entirely or damage them to a point where their chances of survival are lowered. If possible, choose a site with a natural windbreak such as forests or hill slopes, or construct a windbreak. The general rule is that **2.25 times the height of the fence** is the distance from the fence that is protected from the wind. Therefore, a 1 m fence will provide 2.25 m protection downwind.

**Infestations** can come in many forms, but the most serious ones involve insects, nematodes, fungi, and bacteria. The range of possible pests is beyond the scope of this book. Insects and diseases specific to particular species are listed in Appendix C. Local forestry extension agents can provide more information on specific insects and diseases in the area. If an infestation is suspected, institute the following procedures.

- If possible, isolate affected trees and burn the infected parts. This will limit the spread of the problem.
- Identify the pest as best you can. Drawings of insects (or photos) will help extensionists identify problems if they cannot visit the site. Most government forestry services have manuals to help identify common insects and diseases. If the pest cannot be seen, a drawing or photo of the effects on the tree(s) can also help in identification.
- Enact controls. Consult extensionists, local people, and other foresters working in the same area for information on possible controls for infestations. All possible techniques should be considered before decision(s) are made. It may be advantageous to use a powerful control, such as pesticides, or a less risky and less expensive technique such as integrated pest management. Other forms of control include wider spacing, plant diversity (this is more difficult with nurseries than in the field), and companion planting.

## **Propagation Methods**

The two methods of propagation are propagation by seed and vegetative propagation. Each has advantages and disadvantages that should be considered in planning the nursery. (For more information on propagation? see Hartman and Kester, n.d.; ICE Manual FC06; Ffolliott and Thames, 1982; Hopitan, 1975; and ICE Manual FC111.)

### *Propagation by Seed*

Propagation by seed is the primary method of propagation used for tropical trees, especially fruit trees. It is a natural method that is easy to implement. It produces a seedling free of virus and with a high root/shoot ratio. Another advantage of seeds is the initial supply of food available to the seedling from the seed endoplasm.

Propagation by seed is carried out in the nursery by either sowing **in pots** or sowing **in beds to produce open-rooted stock**. It is important to decide correctly on which of these two methods to use, as the decision will have a great impact on many other aspects of the nursery and site planting. This is especially true for space, care, labor, transport, and cost considerations.

**Open-rooted stock.** The open-rooted stock method involves growing seedlings in beds and lifting them out when they are mature, with little or no soil attached. Beds can be raised 10-20 cm, or can be at ground level. Make beds of improved soil over the subsoil, or over plastic sheets or concrete pads, so as to prevent the roots from attaching to the subsoil. Open-root stock can be started from seeds in the beds, or from seedlings that are placed in the beds after initial development elsewhere. The major advantages to the open-rooted method are as follows:

- Less nursery care: open-rooted stock require less day-to-day care in the nursery because plants are not as exposed as potted stock, unless the pots are sunk in the ground. Root pruning is not necessary.
- Lower initial costs: The purchase of pots and other materials is not necessary, although other cost factors must be considered (and may favor pots).
- Lower transport weight: Plants are moved without soil, wrapped in protective covers (large leaves, etc.) which prevent them from drying out. They also take up less room, as the seedlings can be stacked atop each other.
- Less time to transplant: Open-rooted stock go into the ground faster at the planting site because they don't have to be removed from pots. This reduces labor requirements during planting.

Disadvantages of the open-rooted method:

- More nursery space needed: Open-rooted stock must be spaced farther apart, so more space is needed to grow the same number of trees. This can add to the overall cost of the nursery and its operation.
- More nursery time needed: Although they require less attention, open-rooted stock must be kept in the nursery longer because they take longer to mature to a form ready for planting. This time adds to the project cost.
- Need for good soil: Open-rooted stock is planted directly into the existing soil. This soil may be improved to some degree, but reconditioning all of the soil will cost a great deal compared to the cost of producing soil for potting. Soil must be kept loose for ease of lifting, and roots must not be allowed to reach a depth where they anchor to the untilled soil.
- More root exposure during planting: Open-rooted stock are lifted out of the ground and transported directly to the site. This increases the chances of roots drying out and being damaged.

**Potted Stock.** A fertile soil mixture is placed in any type of available pot or container. Plastic bags, which are often available from government operated nurseries can be a substitute for regular pots. If using bags, cut holes in the bottom to provide drainage. Embed viable seed into the mixture, and at the desired age, carefully remove both the seedling and the soil ball from the pot and transplant them into the ground. The pot can be reused many times. Some pots can be planted with the tree and will decay in the ground, feeding the plant and allowing the roots to grow through. Advantages to the potted stock method are as follows:

- Soil: Good soil brought in to the nursery or developed (by composting or other methods) can be substituted for poor on-site soil.
- Seedling spacing: Seedlings can be placed closer together, requiring less overall space for the same number of plants than the open rooted method.
- Less nursery time: Potted plants develop faster and are ready for planting in less time than open-root stock.
- Ability to wait: As long as potted plants are kept watered and their roots pruned, planting can be delayed. Open-rooted stock must be planted immediately. This is important if planting could be delayed for unexpected reasons.
- Less root damage: Potted trees suffer less damage to the roots during transport and transplanting than open-rooted trees because of the protection provided by the pot.

Disadvantages to the potted method:

- Root pruning required: The roots of the potted plants must not be allowed to grow out of the pot or start spiralling inside the pot. This will lead to poor root development and hinder the trees' chances for survival. Every so often all pots should be lifted up and roots trimmed at the drain hole.

- More space needed for transport: Because pots cannot be piled on top of each other, more space is required during transport from nursery to planting site. An alternative is to outfit a truck or other transport device with shelving.
- Additional weight during transport: Potted plants are heavier than open-root stock because of the soil. They must also be watered prior to transport to avoid drying out. This adds to the weight of the plant.
- Higher initial cost: Pots must be bought either from local crafts men (preferred) or imported from outside the community (such as plastic pots and bags). Many different pot designs are available. Pots must be ordered far in advance, as their absence will delay the entire project.

**Steps in Seed Preparation.** Obviously, seeds have to be gathered prior to planting and prepared in one form or another. There are four important steps to seed preparation: collection and extraction, storage, scarification, and sowing. (For species specific information see Appendix C.)

Collection and Extraction: There are two ways to collect seeds: order them from a seed supplier or collect them from the field. In obtaining seeds from an outside source, it order well in advance to ensure that seeds needed for the nursery or planting projects are available at the designated startup date.

Seed suppliers normally provide information on preparing their particular seed. To be on the safe side, request the information when the order is placed. Seeds purchased or received from outside sources should be fresh, reasonably dry but not dried out, and free of insects and other pests. Most government extension nurseries or private agricultural research institutes supply seeds free or at minimal cost.

If the tree species selected is available in the area, collecting is an excellent method for acquiring necessary seeds without the bother and cost of purchasing from suppliers. The best seeds come from strong, healthy parent trees which are disease free, bloom early, produce copious amounts of seeds or fruits, and in general exhibit qualities typical of the species. Groves of trees have an advantage in their greater variation in size, height, etc. Otherwise, more than one or two sources of seeds should be used to ensure a degree of variation in the parent material.

Harvest time is determined by the degree of ripeness of the fruit, which is indicated by a change in color, or by the softening of the outer tissue of the fruit and a hardening of the seed. The pod produced by most leguminous plants begins to dry out and turn brown to black. Overripe fruit may be lost to insects. One way to increase the efficiency of collection is to spread out mats beneath the trees and collect the seeds as they fall on the mat. Often the first fruits to fall will be infested with insects. Sweep them away and collect the fruits that fall next.

Seed collection can be a job the entire community can get involved in. Collect seeds as quickly as possible to avoid predation by insects and other seed-eating animals. If predation is very high, the seeds can be collected while they are still immature.

Germination rates will be lower than with mature seeds, but they may be greater overall due to the reduced predation.

The method of extracting seeds from fruit depends on the type of fruit. Hard fruits (nuts, or stones inside soft fruits) may need to be ground using mortar and pestle or stones. Grinding can be done in bowls or on clean, hard ground. Some seeds may be released by soaking the outer shell and then drying it, causing it to crack. Soaking may also soften the shell, making it easier to pound the seed out. All pounding must be done with care so as not to damage the seed. Following extraction spread the seeds on a hard, shady, dry area to facilitate drying. Do not put light- or heat-sensitive plants in the hot sun.

Seed Storage. Seed storage is very important in order to keep the number of seeds needed for a project available and in good condition, especially since seeds may have to be collected and stored over a period of time until the necessary total is obtained. Seed storage is also a good way to maintain seed stocks for expansion or replacement, and to have extra seeds available for anyone interested in growing trees.

Seeds must be dried a bit before they can be stored, or they will rot. To dry them, remove all fruit from the seed. They should be air dried in the shade, as drying in the sun will overheat them and destroy their ability to germinate. Boxes that allow air circulation, such as ones with screening or other open bottoms, are good for both drying and storage. Whatever container is used, it must allow air to circulate and permit easy access to facilitate removal of spoiled seeds and rotation of seed positions. (See Illus. 5-11.)

Illus. 5-11. Seed Drier

ILLUS. 5-11 Seed Drier

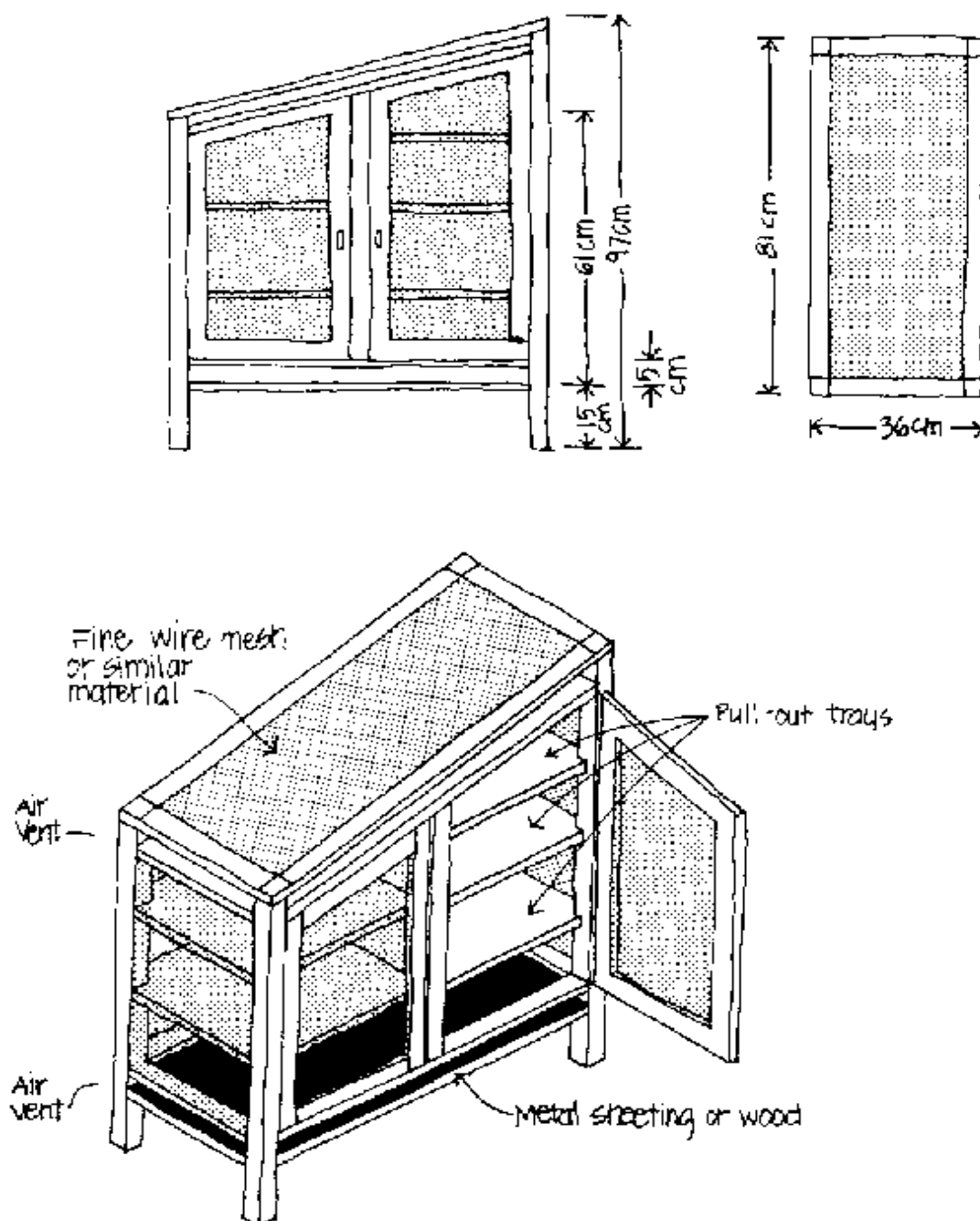

(Watson, 1981)

Mark seed containers well and record their contents. Include information such as the species type, day(s) they were collected, where collected and who collected them, when storage was started, and the number of seeds in the container. Other information may include treatment of seeds, length of

drying time, and germination times. Seeds must be checked frequently for spoilage, damage, and disease. Remove bad seeds, and turn the seed stock over frequently.

Scarification. Scarification is the method by which the seed is prepared for planting and germination. Many seeds must be pretreated to stimulate germination. In most cases, the germination rate is increased with some type of preparation. The types of seeds that almost always need some kind of scarification are those with glossy, hard covers. The two most common methods are soaking in hot water and scratching. Soaking is preferred, as there is less chance of damaging the contents of the seed. For soaking, place the seeds in hot water (boiling water allowed to cool for 5-10 minutes) and let them stand for a few hours or overnight. Seeds are then ready for planting. For scratching, scratch or pound the outer layer with a knife, hammer, or stone. This allows water to reach inside the seed, stimulating germination. Some seeds may require both methods.

Methods of Sowing. It is extremely important to sow seeds correctly, as the success of a project may depend on whether or not the seeds were planted in the correct fashion. When seeding in pots or nursery beds, it is important to prewater and weed. Two weeks before sowing, water the pots and beds every day. This distributes the water evenly and thoroughly throughout the soil and stimulates the growth of fungi and bacteria that are necessary for plant development. Daily watering will also germinate weed seeds in the soil, which can then be removed prior to sowing. This saves time and increases the survival rate of the seedlings.

Sowing in Pots: Sowing in pots is a simple process. Fill pots with soil (a wide-mouthed funnel helps) and water two weeks before sowing. Remove all germinated weeds. Lay the tree seed flat and push it into the soil with the thumb, and then cover it with soil. (See Illus. 5-12.) The depth of soil depends on the tree, but as a general rule it should be three times the smallest diameter of the seed.

Illus. 5-12. Sowing in Pots

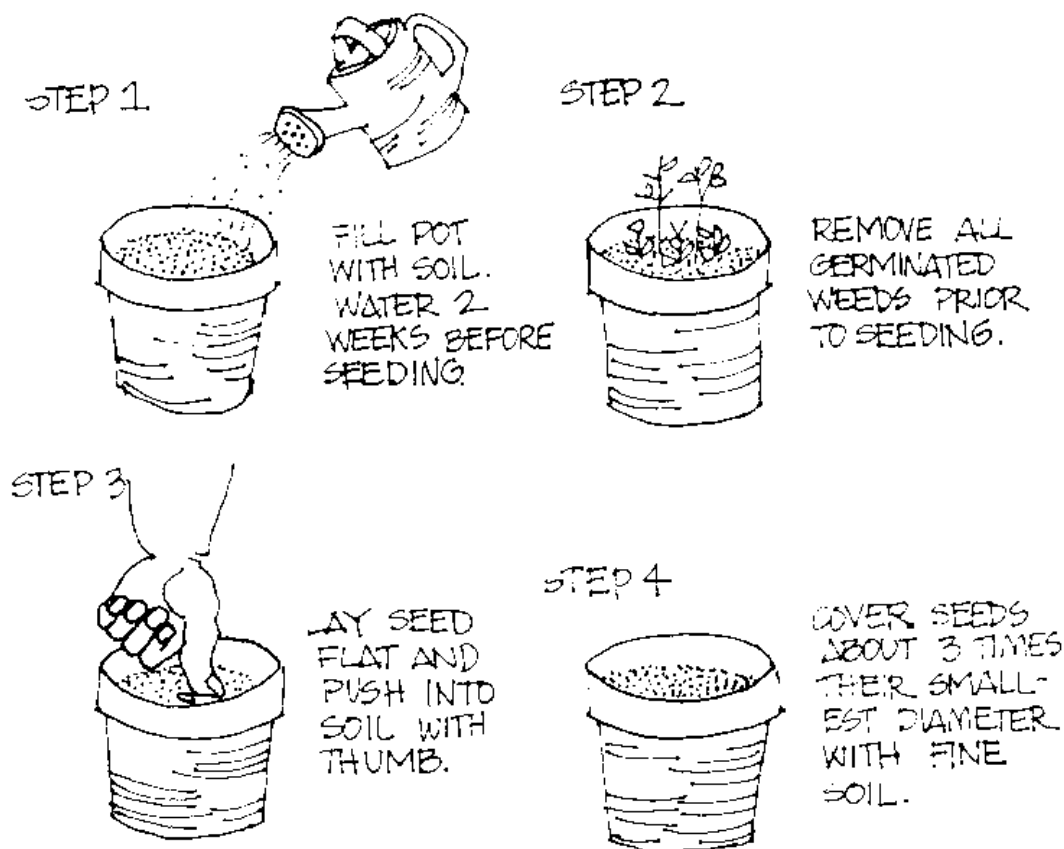

Illus. 5-12. Sowing in Pots.

(Weber, 1983)

(Weber, 1983)

The number of seeds in a pot depends on the expected germination results. If the tree species has a good germination rate, one seed is enough; otherwise two or three seeds may be necessary. To determine the rate of seed germination, place 1020 seeds between wet pieces of cloth or in a porous bag until the seeds germinate. The percent that germinate will give a good indication of the viability of the stock. This will determine the number of seeds to plant per pot.

Open-Root Sowing in Beds: Open-root sowing in beds is similar to potted sowing, except that more seeds are planted. Again, the soil should be watered two weeks before sowing and weeded. A string stretched along the long axis of the bed helps to keep the planting straight, making cultivation and weeding easier later on. Once the seeds have germinated and the roots are well established, thin to the desired distance. It is a good rule to space the plants so the outer leaves do not overlap. This will aid in the prevention of disease. (See Illus. 5-13.)

Illus. 5-13. Sowing in Beds.

ILLUS. 5-13.

Sowing in Beds.

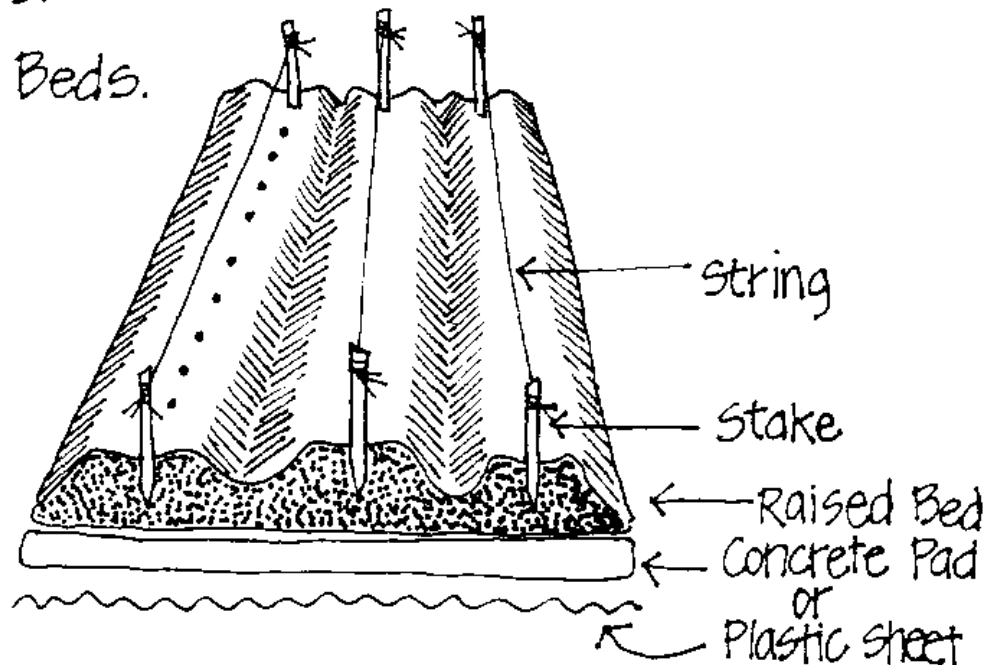

Sowing at Stake: Sowing at stake is only mentioned briefly, as it negates the need for a nursery. Some advantages exist for sowing at stake, including initial vigor and a firm beginning, less need for skilled labor and transport, and less damage to the taproot. The disadvantages to sowing at stake have to do with productivity, and in Plastic Sheet most eases they outweigh the advantages (exceptions exist, such as for Leucaena).

The disadvantages include increased difficulty in inspection due to the widespread distribution of the seedlings, holes in the planting pattern due to seedling death, predation, the difficulty of protecting and monitoring the seedlings, and the variable nature of seedling development. When nursery plantings are used, the land can be used for other means (farming, livestock) until the seedlings are ready, thus increasing its productivity. This option is not as easy to carry out when sowing at stake. Watering, weeding, and shading are also very difficult.

To sow at stake, clear and plow the site one month prior to planting. Two weeks before sowing add mulch, topsoil, ash, and compost and/or rotted manure to the soil, or to each planting hole. Place three to five seeds in each hole, 13-15 cm apart for ease of thinning. Use more seeds if the germination rate is poor. Seeds can fall victim to any number of domestic and wild animals and insects. If predation is high, individual fences of thorns or other materials may have to be used. During dry spells, it may be necessary to water each seedling. It will also be necessary to weed

and thin each hole. Weed the immediate area around the plant, and use banana or palm leaves stuck in the ground to provide shade.

### Vegetative Propagation

Vegetative propagation is a method by which a complete plant is reproduced from one of its parts. Vegetative propagation is generally used to replicate superior or rare tree specimens, and to shorten the time in which fruit trees reach maturity and productivity. The major types of vegetative propagation are **division**, **marcotting** and **cuttings**. **Grafting**, although not technically considered a type of vegetative propagation, is also a popular method. (For additional information of methods of vegetative propagation, see Hartman and Kester, Plant Propagation: Principles and Practices.)

In order to propagate seedlings through vegetative means it is necessary to understand the crucial parts of a tree. (See Illus. 5-14.)

Illus. 5-14. Parts of a Tree

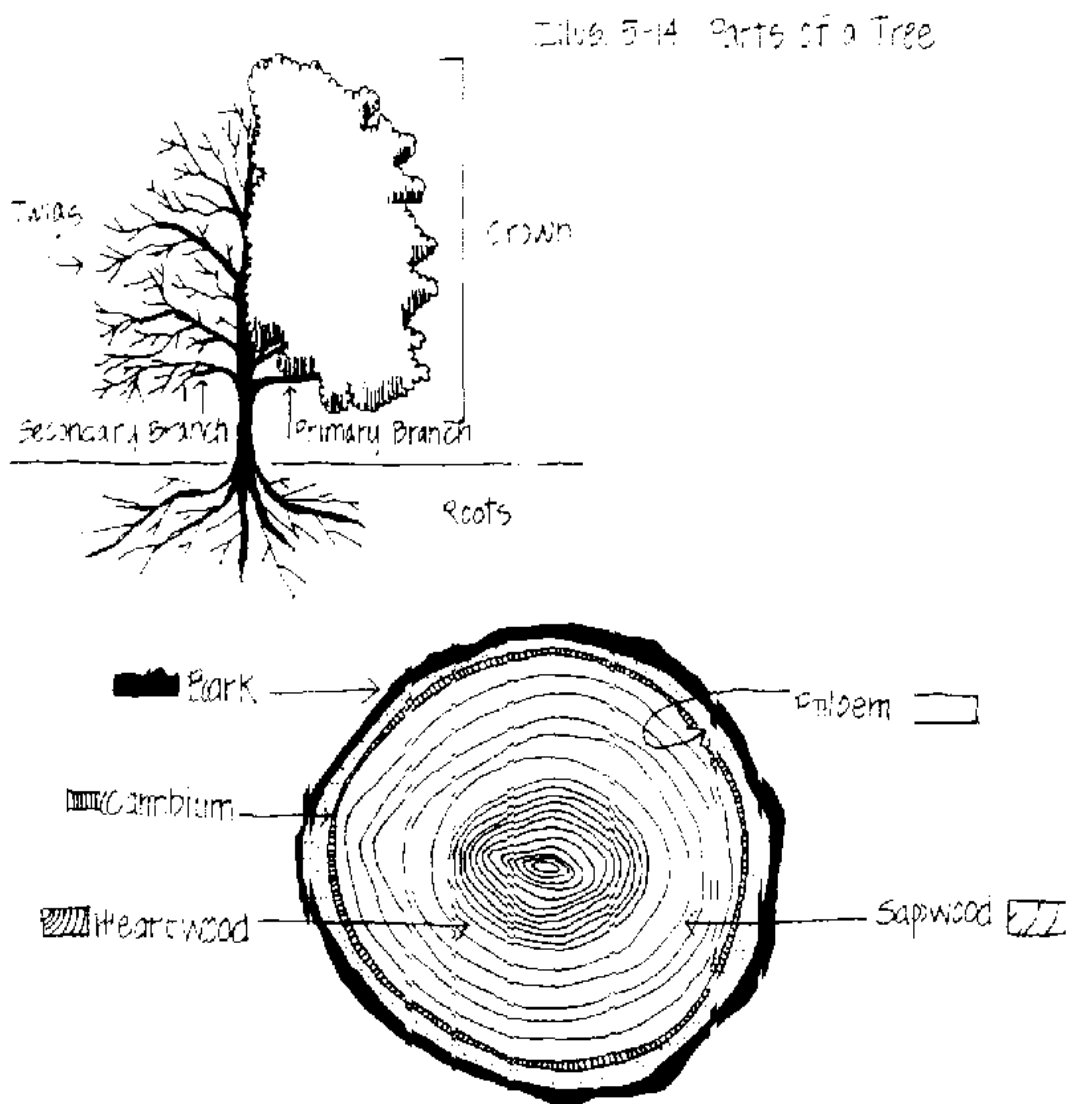

**Division:** In division, a part of the plant is stimulated to grow new roots and shoots and is then separated from the parent plant. Division is best done on plants like banana and pineapple, which naturally develop side plants or multiply by. The easiest division methods to carry out in the field are stooling and layering.

Stooling is the severe pruning of an established plant, one to two years old, and the covering of the plant base with soil. As new shoots emerge from the stump, they are covered with soil so that roots



develop on the new shoots. These root/shoot parts are then removed and planted separately as new plants. (See Illus. 5-15.) The procedure for stooling is as follows:

1. Cut down an established parent plant, about 1- 2 years after planting, approximately 2.5-5 cm above ground level. Seal the cut, not the stem, with wax or other available sealant.
2. Partially cover the emerging roots with soil, always leaving some leaves exposed. Eventually the soil should reach a height of 15-20 cm.
3. As roots develop on the individual shoots above the parent plant, collect and treat them as new plants.
4. Expose the parent plant to the original soil level to start the process again.

Illus. 5-15. Stooling

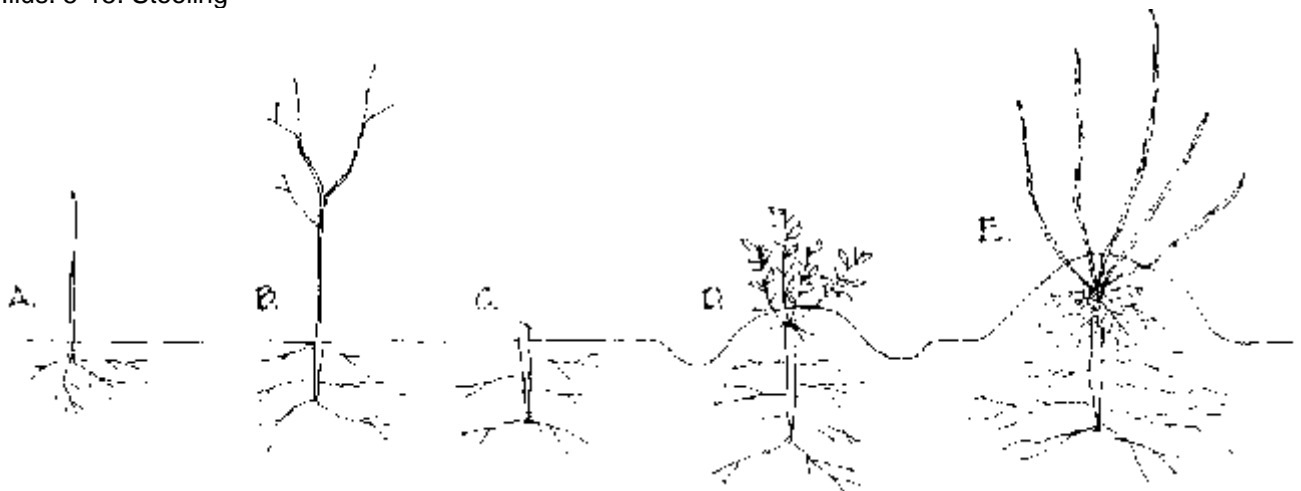

A = Newly planted parent. B = Established parent. C = Parent one year after planting. D = New shoots. E = Rooted shoots on the stool ready to collect.

Layering includes many techniques, any of which can be modified in the field. The basic technique forces the parent plant to grow close to or under the ground, covering parts of the stem with soil and causing the parent to develop new roots on the stem. The stem and roots are then removed and planted as new plants. Most layering techniques take a long time. A common form of layering is the etiolation method. (See Illus. 5-16.) The procedure is as follows:

1. Plant stock at 45 degree angles, facing the same way, 1.8 m apart.
2. After one year, peg the plants flat and cover them lightly with soil 2.5 cm deep.
3. When new vertical shoots form, place a heavy covering of soil (to one half the height of the shoot) on top. Maintain this depth by periodically adding new soil.
4. When the shoots mature, cut them off and plant.

Illus. 5-16. Layering

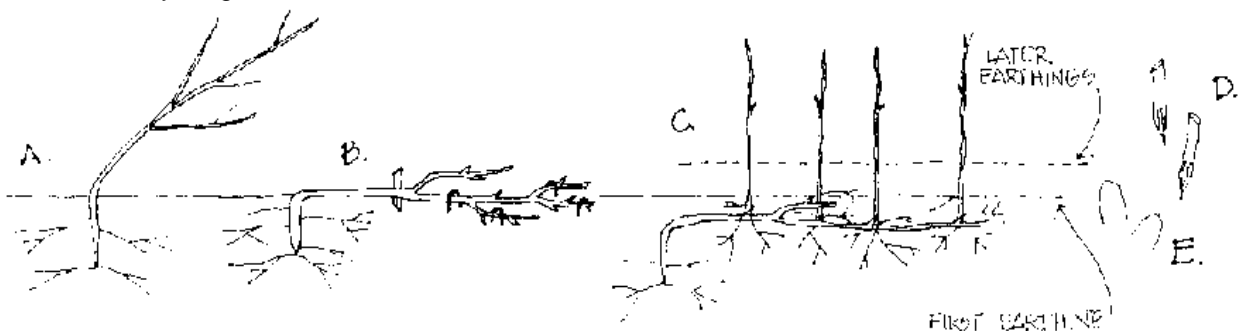

A = Newly established parent. B = Established and pegged. C = Rooted shoots on the parent. D = Home made wooden pegs. E = Wire (gauge 10).

**Marcotting (air layering).** Marcotting is an ancient method of propagating plants. It differs from other methods used because the stem is induced to the root while still attached to the mother plant. It is practiced on many types of fruit. These include jackfruit, guava, guayabano, avocado, mango, cashew, and citrus. Marcotting is an easy, well-proven method of propagation.

For marcotting, the condition of the stem is extremely important. Young stems, such as year-old shoots, are best as they are generally the fastest growing parts of the plant. The stem should be completely girdled, not simply notched, since the flow of starch down the stem must be completely interrupted in order to promote new root development. This must be done without interrupting the flow of water upwards in the xylem or bark. Care must be taken in determining the depth of the cut. The length of the girdle is not critical, but it should range between 0.3 and 7.6 cm. Generally, the best time to start the process is 30-100 days before the rain or planting season, but timing is not a crucial factor. The procedure is summarized as follows:

1. Girdle stem (removal of a ring of bark around it) below a node 3-5 cm long. Cut to the depth of the cambium layer. After removing the ring of bark, scrape the cambium layer but not too deep to prevent healing before root formation takes place.
2. Cover the cut with a rooting medium and seal it with a water-retaining material such as sphagnum moss, coconut husk, sawdust or wood chips. The medium should be open in structure, allowing air and water to flow in and out of it. When roots develop, cut off the stem below the girdle and plant it as a new tree. For plants that root easily this can be accomplished in as short as one month. It may take from six to 12 months for those that are difficult to root.
3. Wrap the medium tightly with a waterproof covering that will prevent drying. It is especially important to tie the top of the cover to prevent excess water from flowing down the stem into the medium during periods of high rainfall. The rain will rot the medium and the developing roots. Polyethylene is normally used for the wrap, as it allows observation of the roots as they develop and is completely waterproof. If possible, shade the wrap to prevent overheating in the sun.
4. Remove the wrap and slowly remove the new plant by making slightly deeper cuts below the root bundle over a period of 1-2 weeks. After cutting, remove some of the leaves and place them in a nursery (in pots or as open-rooted stock) until they have developed fully and can survive field planting. (See Illus. 5- 17.)

Illus. 5- 17. Marcotting

Illus. 5-17 Marcotting

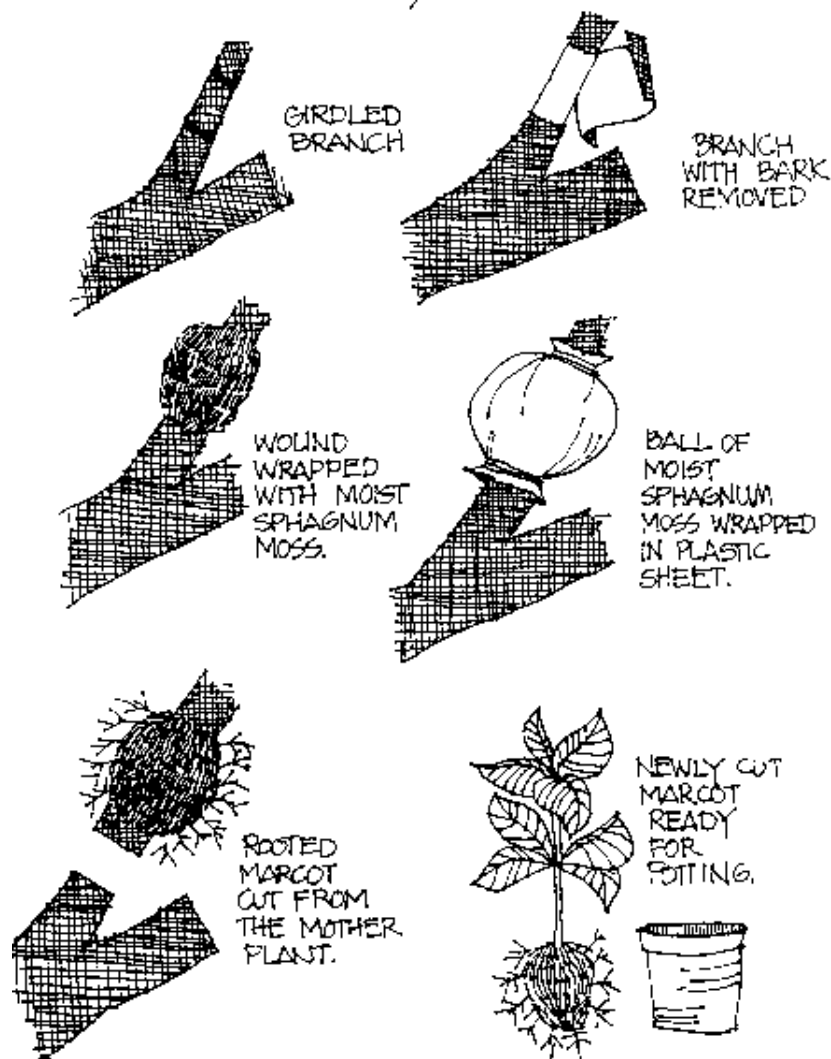

(Garner and Chandri, 1976)

**Cuttings.** The procedures for developing new plants from cuttings involve removing a part or parts of a plant and placing it in a medium in which it can mature into a complete plant. Most parts of the plant can be used, such as the root, stem, leaf, bud, leaf-bud, etc. The medium should be moist and rich, and the cutting must be protected until it is planted.

Cuttings are effective for plants whose parts quickly develop new roots, and for non-woody plants upon which division techniques cannot be carried out. Because the cutting has no parent plant to draw support from (as in layering), it is necessary to provide artificial support in the early stages of growth. Carrying out cutting techniques requires that the following criteria be met:

1. The part to be reproduced must be healthy and vigorous, neither too mature nor too immature. The best cuttings are from the tops of the trees, where growth is more vigorous, the shoots are firm, and a high leaf/shoot ratio exists.
2. The treatment of cuttings is very important. Adequate temperature and aeration at the rooting end of the cutting are necessary. Water must always be available in proper amounts. When collecting cuttings, protect them from drying. The best way to do this is to collect them early in the morning, when temperatures are low and the plants are fully turgid. Wrap them in moist covers until you are ready to transfer them to a planting medium. Avoid putting the cuttings in water, as many important nutrients at the base of the cutting will be washed away.

3. The planting medium should be a mixture of sand, clay, loam, moss, and/or fiber. It should be prewatered and weeded before the introduction of the cuttings, as excess competition from weeds for water will adversely affect the cuttings' chances of survival. It is also very difficult to remove weeds without damaging fragile cuttings, since their roots often intertwine. Protection from drying and the sun can be achieved by placing cutting beds in the shade, in pits or trenches, or under baskets or makeshift tents and tunnels. The planting environment must keep the plant alive and provide for the start and development of new structures. The greatest problem will be preventing the cuttings from drying out, especially cuttings that must develop roots.

The general rule for temperature in the medium is warm bottoms and cool tops. Keep rooting beds warm to help roots develop.

This can be achieved by warming bins or covering the soil with dark material to absorb sunlight. Warm water can also be used. To keep the tops cool, spray a fine mist of water regularly throughout the day. This will allow cooling by evaporation and help prevent the plants from losing water. Some nurseries have automatic mist machines. Every several minutes a timer activates the release of water through several nozzles strategically placed in the bed. Although this is an easy way to provide water, the system requires electricity and capital outlay. (See Illus. 5-18.)

Illus. 5-18. Mist Sprayer

Illus. 5-18. Mist Sprayer

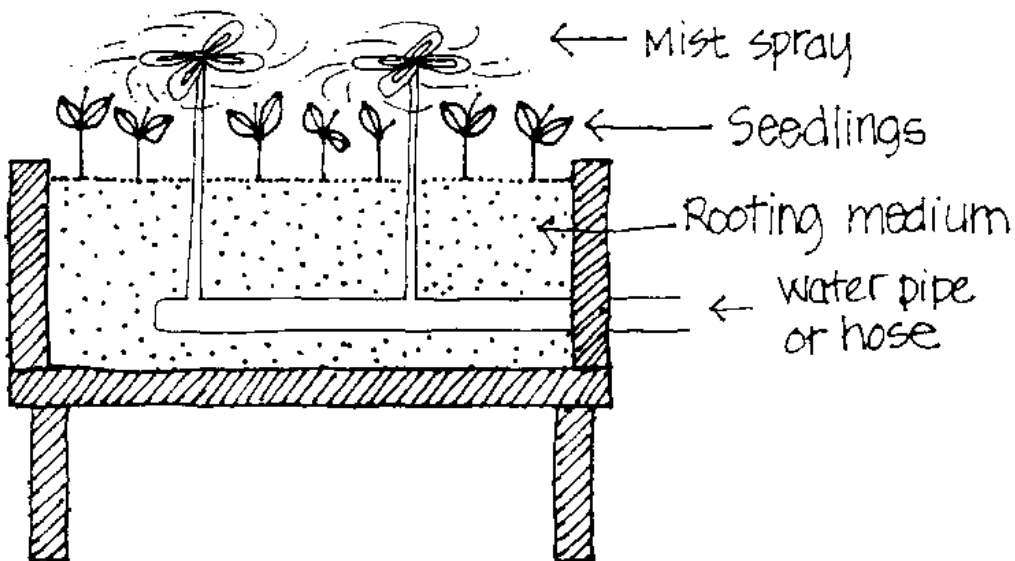

4. When the new plants are mature, they must be hardened off; that is, made ready for living in a harsher environment. To do this, gradually reduce the amount of misting during development until the plant is only misted during the hottest part of the day. Shading should also be gradually reduced. Increased watering of the medium may be necessary to maintain turgidity when hardening is carried out. At this time, nutrients can be introduced to stimulate growth and complete development.

5. Move plants carefully to the nursery or planting site, and plant them as quickly as possible.

Many of the new plants developed from vegetative methods of propagation should spend a period of time in the nursery to increase their chances of survival when planted in the field. Often they must be placed in beds and treated as open-rooted stock.

**Grafting.** Grafting is a process of fusion between two different plants. It allows the multiplication of parts of one plant at the expense of another. Grafting is used for plants, especially woody plants and certain fruit trees, that cannot be easily propagated by division or cuttings. The objective is to use

plants selected for their specific favorable properties. For example, good fruit-bearing stems from one tree may be grafted to a tree with superior root characteristics. Grafting can also be used to repair damaged trees, thus bringing them back into production quickly. Sometimes grafting is the only way to propagate a certain variety, or cultivar (cv.). Finally, grafting can be used to invigorate weak plants.

There are four requirements for successful grafting which are discussed below. They are compatibility, live parts, wounding, and anchorage.

Compatibility refers to compatibility between the root stock (the base plant being grafted to) and the scion (the piece from another tree to be fused to the stock). The rule is that stock and scion should be at least in the same phylogenetic family. It is better if they are in the same genus. The closer the two trees are related, the greater chance for a successful graft.

Live Parts are necessary for a successful graft. In other words, both the stock and scion must be entirely alive; attempting to use either with dead parts will hinder grafting success.

Wounding is the initial step in a successful graft. The cambia of both the scion and stock are exposed, placed in contact with each other, and allowed to heal as one scar to seal the two parts firmly together. (See Illus. 5-19.) This can be difficult, since stock and scion may have different diameters, or their internal tissues may be of different sizes.

Illus. 5-19. Cambial Contact

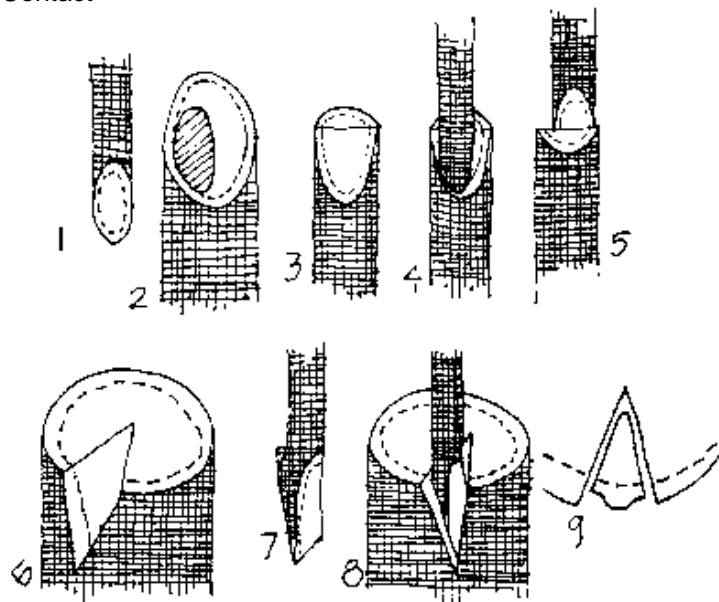

1 = Scion with thin rind. Cambium (dotted line) close to the outside of the rind. 2 = Stock with thick rind. Shading indicates cut surface of scion and limits of cambial contact. 3 = stock prepared to achieve good apical and basal contact with scion cambium. 4 = Scion applied to stock. Note good contact at base and matching of inner rind (cambium) rather than outer rind (bark). 5 = Good cambial contact at top of stock. 6 = Large stock with thick rind prepared for thin scion. 7 = Scion with thin rind. 8 = stock and scion fitted. Note parts of stock rind outside the scion. 9 = cross-section. Note alignment of cambia and unmatched barks. (Hopitan, 1975)

Anchorage is necessary to make sure that the alignment of the cambia and other parts remains intact. As with any wound, continually opening it impedes proper healing. Good anchorage keeps the seal unbroken, allowing the two parts to heal together. Anchorage is achieved by tying the stock and scion together in various ways; the cuts themselves can also be made in such a way as to hold the parts in place, as in wedge grafts. Scions can be nailed directly onto big trees. Fastening materials include natural fibers such as raffia, rubber strips and patches, and plastic strips.

Proper scion and stock selection is also important for success. **Scions** should be picked from shoots that have been exposed to light at the upper and outer part of the donor tree. These shoots are superior because they tend to be better developed. Also, because they are situated toward the outside, they have remained drier and freer from mildew. Avoid the apex, as its growth is too lanky.

**Stock** should be mature plants with healthy, well-developed root growth, located in an area with space adequate for additional growth.

The basic procedures for all grafts are simple but require practice. Specific instructions for various types of grafts will follow.

1. Cut scion and stock and prepare them according to the method to be used. Strong, sharp tools are needed, such as knives, chisels, cleavers, shears, and saws. They must be kept clean. After cutting, remove the scion leaves at the base of the stem to save water until the graft has somewhat healed. It is necessary to provide cool storage for the scions if there is a long wait before the graft occurs.
2. Fit the scion and stock together, making sure the cambial layers are well exposed to each other. Anchor the parts reasonably tightly so as to prevent movement but not to inhibit growth in any way.
3. Seal the outside of the graft or wound. Many recipes for seal are available. They generally include mixtures of clay, wax (such as beeswax), and other materials. Local resources should be used when possible. It is also advantageous to check with local growers to find out materials that are cheap, easily available, and commonly used.

The easiest type of grafting is **detached grafting**. Other forms, such as approach and bench grafting, are more cumbersome and require a lot of room and time to carry out. Detached grafting, on the other hand, is simple enough to carry out with minimal tools and space. It also requires less labor per graft and is easier for mass production of grafts. The two best types of detached grafting for community forestry work are bud and apical grafting.

**Bud grafting** involves using a single bud or cluster of buds as the scion. A small amount of supporting tissue is normally included in the scion. **Shield** (or T-budding) and **patch budding** are the easiest forms of bud grafting and produce good results.

Shield budding is commonly used on citrus. It is a good method for stock with a flexible rind (outer layer) that is not too thick and is easily separated from the wood. The current season's growth of the donor plant provides the best scion bud-wood, as the buds are small enough for easy insertion. Buds from older growth can be used only if they are still actively growing and are not too big.

For shield budding, a good bud is removed from a branch by a shallow cut which slices out the bud and underlying cambium. (See Illus. 5-20.) Start the cut about 1-2.5 cm below the bud, pass under it, and come out about 5-7 cm above it. The part cut out behind the bud is the bud shield. It should have a sliver of wood around it for support of the cambium, yet be thin and flexible. This will assure that the scion will be able to bend around the stock's stem. A long cut provides a handle to help manipulate the scion. The handle is cut off after inserting it in the rootstock.

Illus. 5-20. Shield Budding

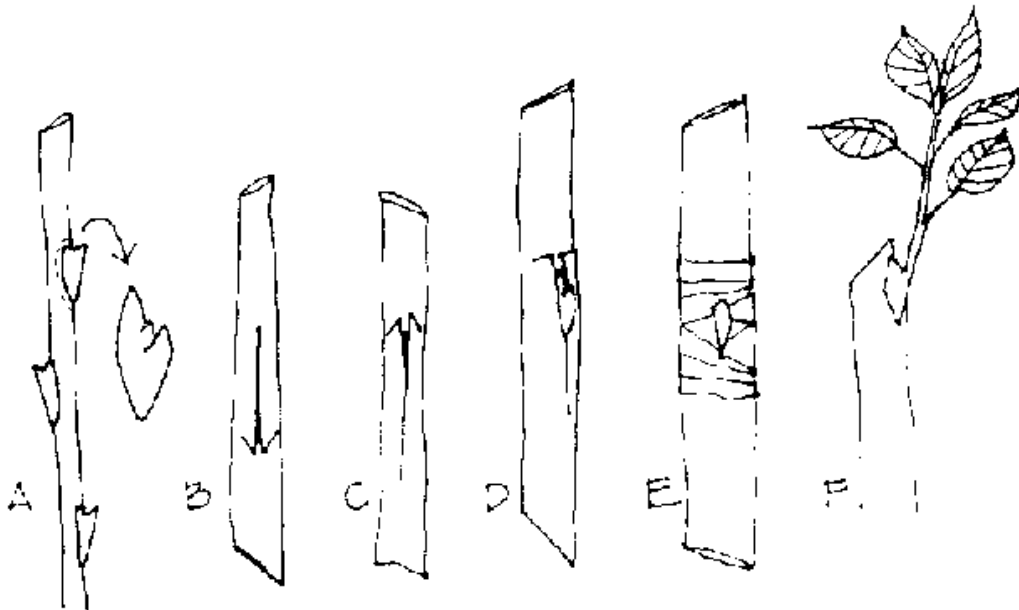

A = Budstick with bud removed. B = Rootstock with inverted T cut. C = Rootstock with a regular T cut. D = Bud inserted into rootstock. E = Bud secured in place with a budding tape. Plastic ribbon can also be used. F = Rootstock cut above the point of union. (Hopitan, 1975)

Following removal of the bud, make a vertical incision about 2-3 cm long and as deep as the bark. Make a cross-cut above the vertical cut, thus forming a T-shaped cut. Peel the rind away carefully, and insert the bud into the slit made on the root stock until it is even with the cross-cut. Once the bud is set in place, tie the T-cut securely with a budding tape. Keep it covered tightly for 10 to 14 days, then unwrap and expose the bud.

Variations of the shield budding method exist and should be employed when the species or environment demand it. One variation is removing the wood from the shield. Another is the inverted T method, where the horizontal cut is on the bottom. This is used in very rainy areas to reduce the amount of rainwater entering the graft and causing rot. It may also increase the amount of nutrients available to the graft, since T-cuts with the horizontal cut on the top interrupt the food flows from the top of the stock into the scion. For the inverted T method, it is necessary to reverse the cutting stroke on the scion bud, starting just above the bud and extending the cut below the bud. It is a little more difficult to place the scion with this method.

Patch budding is used widely on fruit trees with thick bark. Fruit tree successfully propagated using patch budding include santol, rambutan, and durian.

It is a simple process in which a rectangular patch of root stock is removed and replaced by the same size patch containing a bud from the scion. The stock and scion should be of the same age and diameter. Timing is very important; the best period to carry out the procedure is when the scion buds are just starting an active growing stage.

The procedure involves the following steps (see Illus. 5-21):

1. Make two parallel horizontal cuts, one above and one below the scion budwood. Extend the cut through the bark to the wood. Cut the root stock similarly, but make the horizontal cuts slightly farther apart than on the scion.
2. Make two vertical cuts on the scion bark, connecting the horizontal cuts and forming a rough rectangle. Remove the piece containing the bud. Make a single vertical cut in the root stock and peel the bark back. Slowly insert the scion while peeling back the bark, taking care not to damage the bud.
3. When the scion is fully inserted, make a second vertical cut in the rootstock to remove the loose bark and provide a tight fit. No edges of bark should be exposed.

4. Tie the scion patch to the root stock. It may be necessary to seal the edges of the patch and to shade the bud with a leaf tied above the patch.

Illus. 5-21. Patch Budding

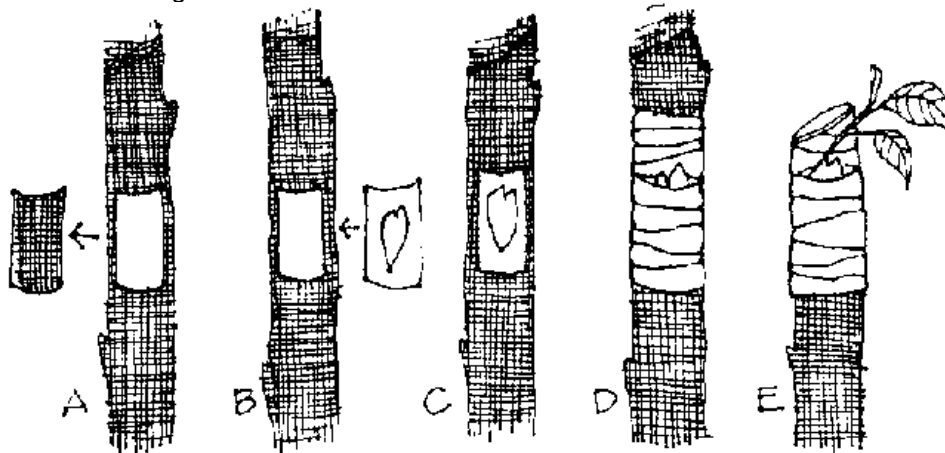

A = Rectangular bark removed from rootstock. B = Rectangular bark with bud removed from the scion. C = Bark with bud placed to the rootstock. D = Bud secured in place with budding tape. Plastic ribbon can also be used. E = Rootstock cut above the point of union. (Hopitan, 1975)

Other patch budding methods include flute, ring, and chip budding. Flute budding is just an extended patch, using up to 7/8 of the diameter of the scion and stock. It is used when a strong anchorage is necessary (see Illus. 5-22). Ring budding is similar, except the scion and stock are completely girdled down to the wood. Both these methods require parallel horizontal and vertical cuts, and the above procedures can be followed. Chip budding is convenient in anchoring and cutting (see Illus. 5 - 23). It involves a thick chip being cut out of both stock and scion. The method provides excellent cambial contact and ease of tying. It is particularly adapted on fruit plants with barks that do not slip easily. It is also useful on grapes.

Illus. 5-22. Flute Budding

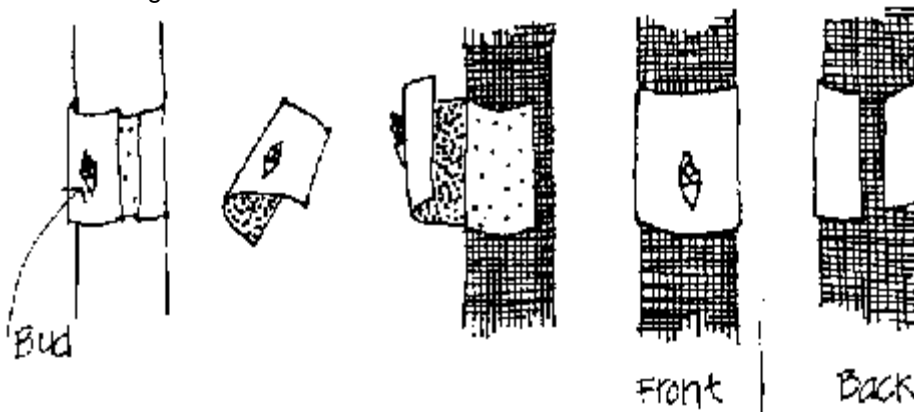

(Garner and Chandhri, 1976)

Illus. 5-23. Chip Budding



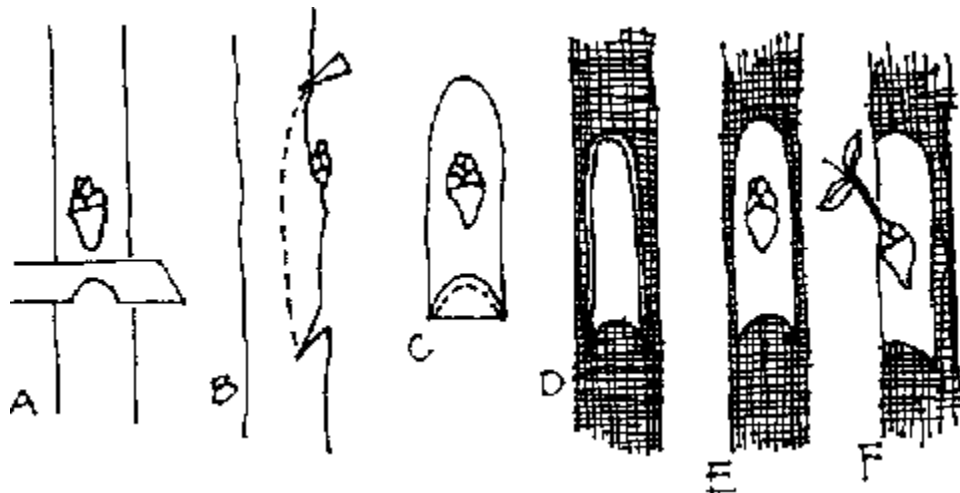

A. Scion notched below bud. B. Chip made above and down and around bud. C. Chip bud removed. D. Chip cut made in rootstock. E. Chip bud placed in rootstock. F. Scion starting to grow. (Garner and Chandhri, 1976)

**Apical grafting** is end-to-end grafting. There are numerous ways to graft in this manner, depending on the connecting pattern used. In fact, the number of methods of apical grafting is limited only by the ingenuity of grafters and their grafting ability. It is good to remember that the same four essential requirements for any grafting technique must be met for apical grafting: compatibility, live parts, wounding, and anchorage. Apical grafting is advantageous for anchorage because the stock and scion are cut to fit tightly, and the pattern used can add to the stability of the joint.

Four apical grafting methods are especially important to tropical Pacific forestry, although many other good methods exist. Each of these leaves a lot of room for variation when necessary. The methods are splice (whir) grafting, whip and tongue grafting, wedge (cleft) grafting, and oblique wedge grafting.

Splice grafting (or whip grafting) involves making single diagonal cuts that match each other in both stock. (See Illus. 5-24.) Diameters of identical size improve the bond between stock and scion. This is the easiest form of apical grafting. Its major drawback is that it is difficult to hold scion to stock when tying them together; they tend to slide apart. The procedure is otherwise simple.

**Illus. 5-24. Splice Grafting**

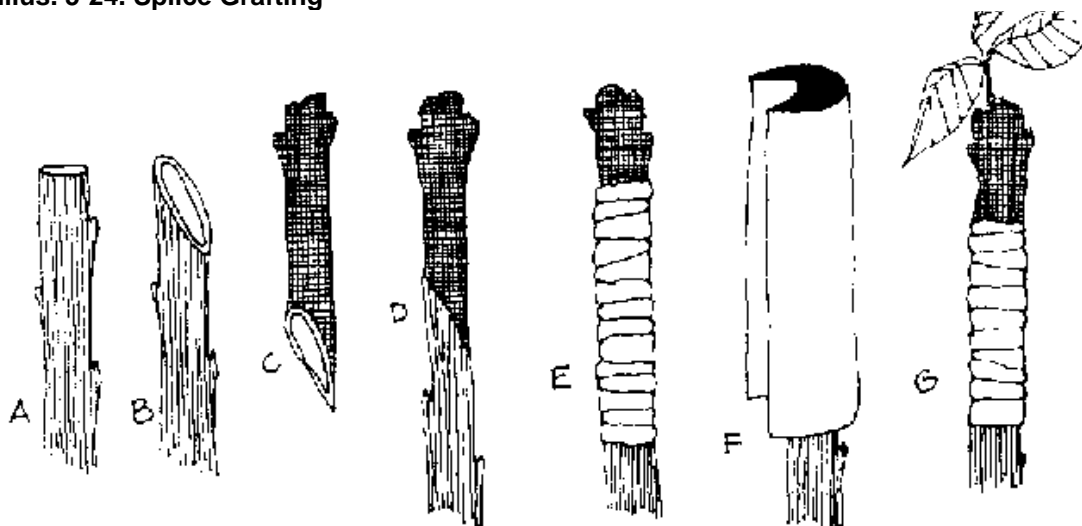

A = Rootstock cut back to the point of grafting. B = Rootstock with a slanting cut. C = Scion with a slanting cut. D = Scion fitted to rootstock. E = Graft secured firmly with a budding type. Plastic ribbon can also be used. F = Scion protected with banana petiole. G = Scion starting to grow. (Garner and Chandhri, 1976)

1. Make a slanting cut, as long as is convenient to manage, at the bottom of the scion. Make a cut of identical length and angle in the top of the stock.

2. Place the open surfaces of the stock and scion together so that the cambial areas are in complete contact. Tie the two parts together and seal the cut.

Splice grafts can be used when stock and scion are of unequal diameters, so long as the cambial regions have good contact. Open tissues should also be sealed, so that excess water does not penetrate the plant and cause rot.

A whip and tongue graft is similar to the above method, but an extra lip of wood (the tongue) is left in the stock to stabilize the union and allow ease of tying, especially for very small stems. (See Illus. 5-25.) A matching insert is cut into the scion to allow the tongue full contact. When good, sharp tools are available, the whip and tongue graft is preferable to a simple splice graft. Its drawback is that it does not work well unless stock and scion are of the same size. The procedure is the same as that used for the splice graft except for the shape and joining of the graft itself.

### **Illus. 5-25. Whip and Tongue Grafting**

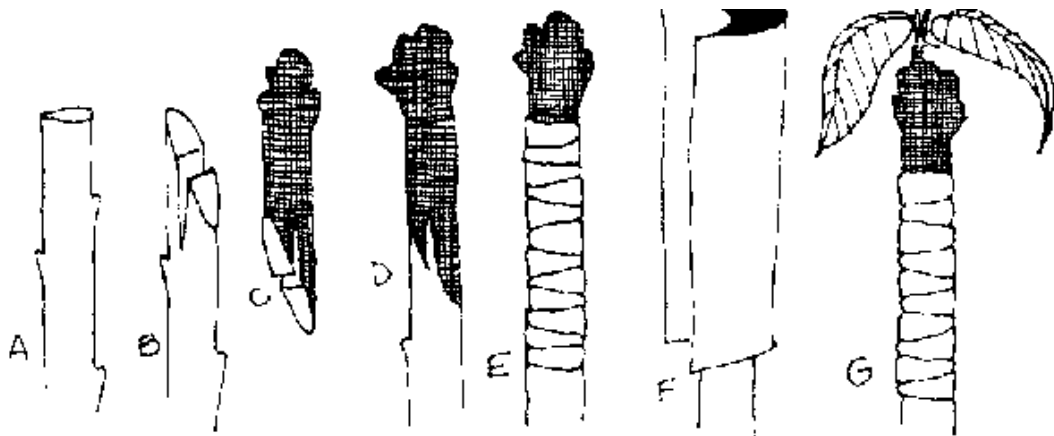

A = Rootstock cut back to the point of grafting. B = Rootstock showing its "tongue". C = Scion prepared with its "tongue". D = Scion inserted into the rootstock. E = Graft secured with budding type. Plastic ribbon can also be used. F = Scion protected with banana petiole. G = Scion starting to grow. (Garner and Chandhri, 1976)

The wedge or cleft graft is a secure graft which can be used on scion that is smaller than the stock. (See Illus. 5-26.) It is also good for joining scions to roots. It is sometimes the only way to graft herbaceous (non woody) materials before they reach the woody stage. As with any grafting method, it is vital that the cambia of both the stock and scion are in good contact with each other. The procedure involves the following steps:

1. Cut the bottom of the scion in the shape of a point or wedge.

2. Cut the stock horizontally at the point of the union, and then split it at its apical (upper) edge. Place the scion in the split so that just the top of the cut surface of the scion is visible above the end of the stock.

3. When placing the scion in the split, keep at least one side of the cambia of both the stock and scion in good contact with the other.

4. Tie and seal the joint.

### **Illus. 5-26. Cleft Grafting**

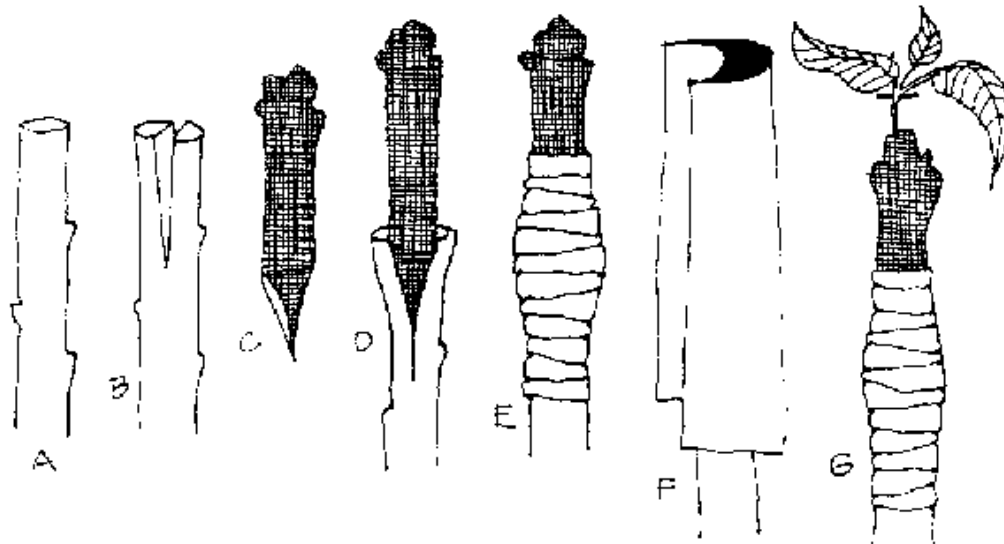

A = Rootstock cut back to the point of grafting. B = Rootstock showing vertical incision. C = Scion showing a wedge cut base. D = Scion inserted into the rootstock. E = Graft secured firmly with a budding type. Plastic ribbon can also be used. F = Scion protected with banana petiole. G = Scion starting to grow. (Garner and Chandhri, 1976)

The oblique wedge graft is similar to the wedge graft, except that it is not carried out at the top of the stock. (See illus. 5-27.) Instead, a wedge cut is made in the side of the stock. The scion is also cut differently; its wedge is not symmetrical (the upper side of the scion wedge is longer than the bottom) because the scion will initially emerge from the stock at an angle, somewhat like a branch, instead of as a continuation of the stem. Later the scion will straighten out. The procedure involves these steps:

1. Cut the scion as short as is manageable. Cut its base into an unequal sided wedge. The long side of the wedge is on the same side as the highest (apical) bud.
2. Cut the stock in the side at an angle no deeper than half its thickness. Open the stock at the cut, and insert the scion with the apical bud at the highest position and the long cut of the scion wedge pointing toward the center of the stock.
3. Let the stock close back on the scion, and then cut off the stock just above the scion. Seal the graft. Tying is generally not necessary.

**Illus. 5-27. Oblique Wedge Graft**

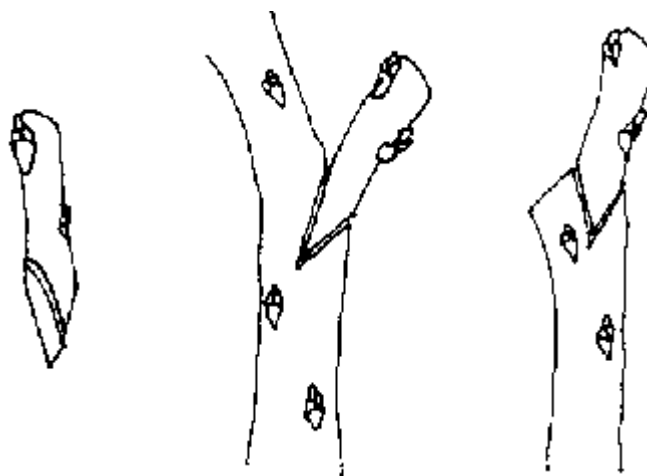

(Garner and Chandhri, 1976)

A method of **approach grafting** commonly used is in **arching**. (See Illus. 5-28.) Inarching is a method of propagation in which the scion is made to unite with the root stock while they are growing

independently on their own root systems. Although it can be done it near the ground, it is usually performed high on the branches where the scion stem approximates the size of the root stock. This necessitates providing the root stock with a rigid support like bamboo or wooden platforms.

To inarch, select an actively growing root stock and bring it to the branch chosen for grafting. Cut a longitudinal section about 4-5 cm long and about half its thickness. Make a similar cut on the scion then fit them together. Tie firmly with a string or cotton twine. When union has taken place, gradually cut the scion below the point of union and the rootstock above the union. Make the first cut about half the thickness of the scion stem. About a week later, make the second cut. If after making the second cut the scion does not show any signs of wilting, cut it off completely. In arching is one of the few methods of propagation that needs little attention. Except for the regular watering of the rootstock, no other treatment is given to the inarched plants after they are tied together.

### Illus. 5-28. Inarching

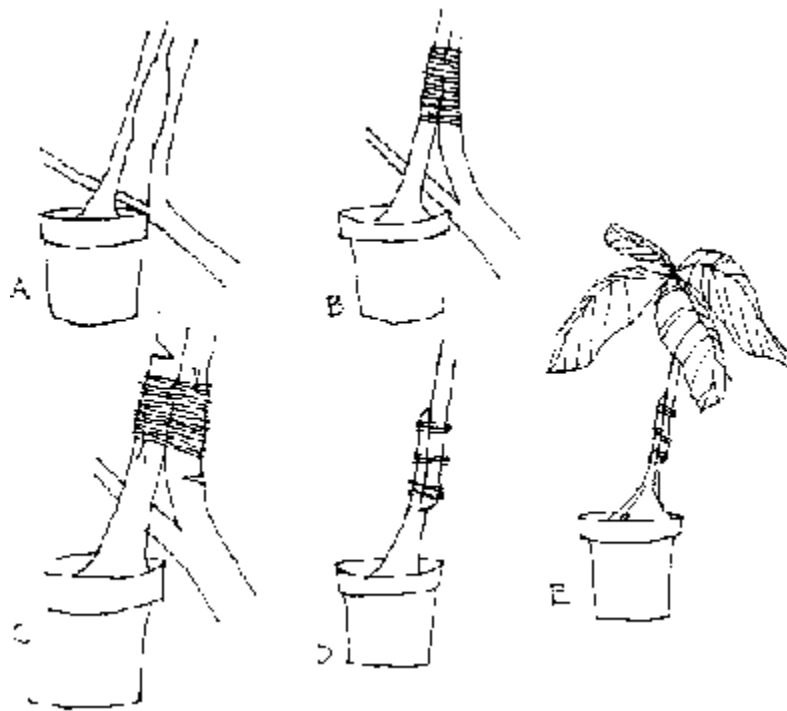

A = Stock and scion showing their longitudinal cuts. B = Scion secured tightly to the rootstock with cotton twine. C = Partially cut inarched plant. D = Newly cut inarched plant. E = Potted inarched plant ready for planting. (Hopitan, 1975)

Another grafting method which deserves a quick mention is **grafting to entire trees**. This is advantageous if a superior cultivar is developed that takes a long time to grow to maturity. A root system of a fully developed tree can be used to propagate the scions of the new cultivar. If a tree loses most or all of its canopy yet retains a healthy root system, it is possible to rejuvenate the tree and save the well-developed root system by chopping off the tree at the trunk and inserting grafts into the stump. There are many ways to do this, and all require heavier cutting tools (such as saw, mallet, and machete) than the other methods. The major problem with these methods is the large size of the cuts, which increase the chances of infection.

### Other Considerations

#### *Care of Nursery Plants*

Seedlings are fragile plants and need special treatment to ensure their survival until they are established. Water seedlings with about 5 ml of water for each plant once a day, even on holidays. This will keep the soil in both pots and beds well moistened. Check pots and beds frequently for adequate moisture by spot-checking pots without seedlings that have been watered or by digging about 20 cm into the beds and making sure moisture has penetrated to that depth.

**Watering.** Water germinating seeds twice a day for about a month, after this the seeds should have sprouted and the roots should be developed enough to cut back to one daily watering. If seedlings wilt, go back to two waterings per day until they recover.

It is necessary to consider different soil types, climate, location, and other factors which will affect water availability. Use common sense to determine any variation in water needs over extended periods of time. Check the state of the seedlings and the soil regularly, even once a day, to maintain seedling health.

**Thinning.** Open-root stock must be thinned after they reach a height of 10-15 cm. After that height root competition will lead to uneven size and poor root development. Thin seedlings to 5-6 cm apart. Use a ruler or premeasured stick to assure even spacing. It may be possible to transplant thinned seedlings into gaps that have developed due to poor germination. Doing so requires very careful handling of the seedling, however, and survival is limited. A more effective method is to reseed any holes in the beds.

**Root Pruning.** Pots must have drainage holes to prevent waterlogging. If roots are allowed to grow out of the holes and develop extensively, they will have to be cut off before the potted plant can be transported to the planting site. After 6-8 weeks, prune all roots extending from pots once a week, or as often as is necessary.

**Protection.** Extra protection from the sun may be necessary for the outer row of pots in a block. Sinking these pots will help reduce water loss and overheating. Remove 5 cm or more of soil from below the outer row. Sink the pots in the hole and backfill as high as possible to the top of the pot, using the soil removed.

**Weeding.** Weeds compete with seedlings for water and nutrients. Weed frequently in beds and pots, using care not to damage seedling roots when removing the weeds.

Soil should be kept friable. Lightly till the top of the soil to allow water and air to enter it easily. Take care to avoid damaging the roots of the seedling. Tilling may be necessary after heavy rains, as soil can become sealed by the force of the droplets and limit water and air entry.

### *Nursery Records*

The need for accurate, daily records of nursery activities cannot be overemphasized. Records provide a history of operations, so that results of techniques and materials used can be adequately evaluated. New procedures, plant types, and other innovations can also be assessed. Records help in project planning as well. As information about the amount of labor or time needed to perform certain tasks accumulates, the data become useful for future costing and other calculations. Worksheet and pay records also prevent disagreements over wages and hours worked.

A monthly report of nursery activities is an excellent way to summarize records, plan for the next month, and explain any discrepancies between the previous month's plans and results. Support from donor agencies is easier to obtain and maintain when activities and results are well documented.

Nursery and other project records should contain at least the following:

- Daily log of activities,
- Any technical notes, such as techniques used, pests discovered and treatments used, and methods used for spacing, watering and feeding of plants,
- Seed and plant histories (collection, treatment, growth rates, etc.), numbers of plants in beds, and success of plant types,
- Amount of time and labor needed for specific tasks, individual workers' histories, and pay worksheets, and
- Monthly report summarizing results, problems, and discrepancies of the past month, and expected results of the next month.

A well-designed project should continue to operate long after the departure of the community forester. A nursery is a long-term, ongoing affair that can be shared by a succession of foresters. The 2-5 year length of service experienced by the majority of Peace Corps Volunteers and extension agents is really just enough time to initiate a project or improve on the work of predecessors. Records allow the knowledge gained by one forester to be passed on to others. This information may be invaluable.

#### *Other Activities*

If the objective of the nursery is to grow plants for a specific project, it is necessary to prepare the planting site well in advance of seedling maturity. Site preparation activities include arranging labor, digging holes, collecting mulch and fertilizers (commercial or manure, or green manure) and making them available at the site, building windbreaks and fences, arranging transportation, and other activities. These activities cannot be postponed until the trees are mature and ready for planting. Failure to prepare the site ahead of time may result in seedlings less capable of handling stress associated with transplanting. Roots may become pot-bound, open-rooted stock may anchor in the subsoil, and plants may become crowded and heavy. The optimal planting time may be missed, forcing planting during dry periods and increasing tree mortality.

The following chapter specifies the tasks required to prepare and plant a project site. For additional details about project planning and timing, see Chapter 4.

## **6. Planting practices**

### **Planning**

Planning is the first, and perhaps the most important, step prior to planting agroforestry-related products. Through early planning and careful scheduling, delays that could hinder tree growth or affect the health of trees can be avoided. Planning is a useful tool for dealing with contingencies (such as bad weather) that might otherwise disrupt planting operations, and planning improves project communications. Show the plan to other community foresters and consider their opinions and suggestions. Keep the plan flexible, so that new techniques and ideas can be incorporated into it. Involve project participants in the decision-making process so that misunderstandings can be avoided.

#### *Permission*

For any planting site, obtain written permission from appropriate officials to assure that operations are not interrupted by disagreements or misunderstandings. Be sure the area is not under dispute and that it does not belong to an absentee owner who will return to claim it. Authority to use an area should cover the entire time period of the project.

#### *Labor*

A reliable labor pool, whether volunteer or paid, is essential for the preparation and continual maintenance of the planting site. Communal tree planting projects throughout the world have been failures due to the difficulty in assuring long-term maintenance of sites. It is often difficult for villagers to understand the benefits of clearing weeds around trees planted for erosion control when work closely related to everyday living remains unfinished. In other words, the rewards from one project may be less tangible than the rewards from another project.

To ensure reliable labor crews for communal projects, provide work incentives. A weeding session could be an on-the-job training session as well. When the desired amount of work is finished, hold classroom sessions on planting practices, processing, etc. Invite another extension agent with a different, yet related discipline such as drying fruits or fish to hold a training session right in the field. Since many of the volunteers will be women as well as men, make sure the presentation is geared to both sexes. The objective is to make the sessions fun, to encourage people to participate. Use your imagination.

Inadequate labor is less of a problem when the project is a cooperative effort between the forester and an individual farmer. In this case, the farmer has a personal incentive to provide the labor necessary

to complete the project. Even so, be sure the individual understands the labor commitment and has the time and/or resources to fulfill the necessary obligations. Often, neighbors learn from neighbors. If the project is a failure, regardless of the forester's advice, it is doubtful the adjoining farmers will request help on a similar project.

### *Water*

Water must be available for both direct seeded and transplanted species. Each seedling will need water when planted. Pick planting sites located near water supplies if possible. If water is not available at the planting site, it will have to be transported with the seedlings themselves. Planting during the rainy season helps avoid this problem, but rain within two days of planting is required to assure high survival rates.

### *Soil*

Soil must provide for the needs of the tree species being used. If the project area lacks good soils due to natural conditions, erosion, or poor maintenance, choose a species with the ability to tolerate poor soil conditions.

Under poor soil conditions, soil improvement from compost or animal manures will help seedlings. Unfortunately, the quantities of compost or manure necessary to fertilize a large area may not be available. If possible, provide an early boost to the seedlings by applying commercial fertilizers. Augment this with nitrogen-fixing cover crops and compost, or additional amounts of commercial fertilizers. Be aware that in order to produce hardy, disease-resistant products, fertilization of nutrient-poor soils is required throughout the length of the project. (For additional information on fertilizers and soil conditioners, see "Soils, Crops, and Fertilizer Use," available from ICE.)

### *Transportation*

Arrange transportation for the seedlings well in advance. They should be moved as fast as is safely possible. Prepare and scout the route to be followed, and prepare an alternate route in case the primary route is closed (due to flooding, etc.). Water seedlings heavily once a day for three to four days prior to transporting them. Doing so will reduce seedling trauma and help survival. Protect seedlings from the wind and sun during transport.

### *Protection*

Protective measures for the site, such as firebreaks, fences, and windbreaks should be in place before planting starts. Roads, footpaths and all other construction should be finished prior to planting as well.

## **Planting**

Planting can be the most rewarding and satisfying part of forestry. It involves site preparation, preparing, transporting, and planting the seedlings, and site maintenance and protection.

Site preparation and planting methods vary by site and project objectives. Some techniques, such as the even spacing of holes and rows, and the construction of fences and roads, are used for larger-scale projects on flat land. Other techniques such as contour planting, grading, and mulching are typical of upland agroforestry systems. These methods will be discussed in great detail in Chapter 7. This section deals specifically with preparing the site and planting the seedlings.

### *Site Preparation*

Whether seedlings are transplanted or sown directly, prior preparation of the planting site is important. Prepare the planting area just prior to removing seedlings from the bed or sowing the seeds. Preparation involves clearing the area of competing vegetation, cultivating the soil, grading, digging holes (if transplanting), and lining out rows. Preparation too far in advance of seedling removal will leave the soil exposed to the wind, rain, and hot sun. All may contribute to degradation and erosion. Preparation that begins after the seedlings are removed may result in their death due to exposure.

Initial preparation of a site requires clearing the land of all unwanted vegetation, including the roots. If time permits, and to avoid overexposure of the soil prior to planting, plant a ground cover such as green manure, which adds nutrients to the soil. Green manures are legumes and nonlegumes that are valued because they provide nitrogen to the soil either through the air or when plowed under. Common legumes are beans and peas. A common nonlegume is rye grass. Green manures can be left in the field when seedlings are transplanted. If rows need to be dug for direct seeding, plow the manure into the soil along the length of the row. (See Illus. 6-1.)

Illus. 6-1. Intercropping Green Manure and Trees

## ILLUS. 6-1 Intercropping Green Manure and Trees

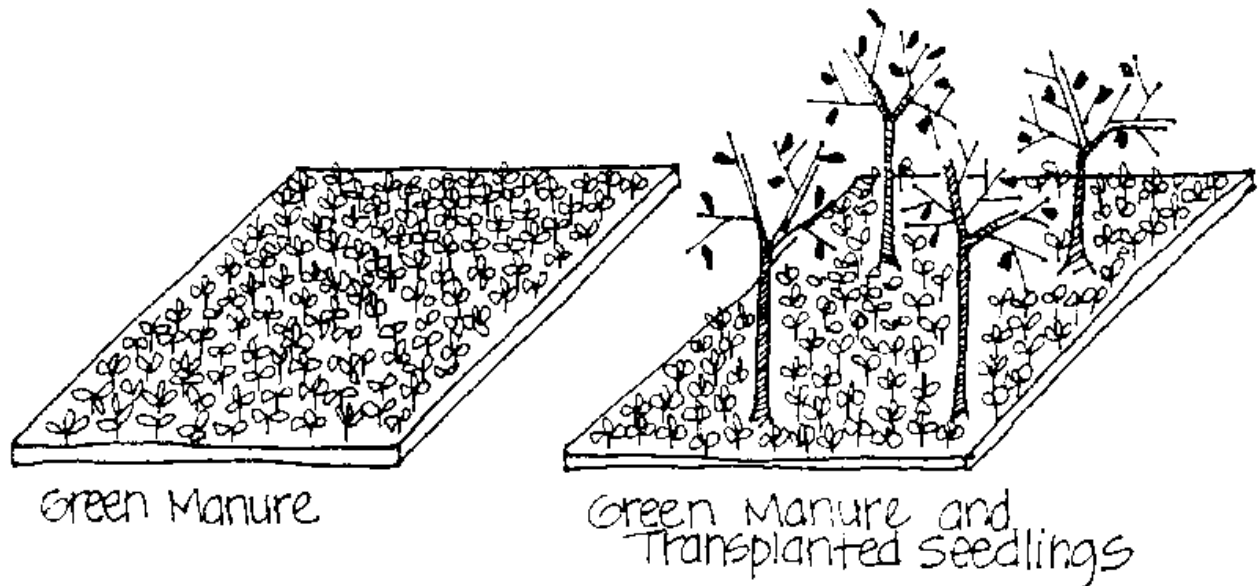

Like green manure, mulch will also protect bare soil from overexposure, as well as provide new plants with nutrients. Mulch can prevent extremes in temperature, hold down weeds, and even improve soil structure and fertility. Types of mulch include cut grasses, rice hulls, corn hulls, coffee and cocoa hulls, corncobs, and cornstalks. Collect adequate mulch beforehand to cover as much of the planting site as possible (see Illus. 6-2). Be careful not to mulch seedlings on wet soils. This may encourage damping-off of young plants. Damping-off, a disease caused by a fungus inhabiting moist, poorly ventilated soil, can be 90 percent fatal to seedlings. (For additional information on mulch, see "Soils, Crops, and Fertilizer Use," available from ICE.)

Illus. 6-2. Mulching



Illus. 6-2 Mulching

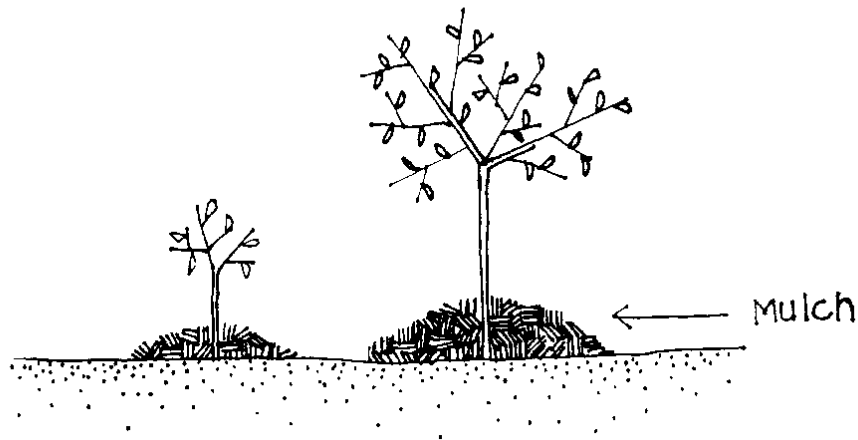

If the site is on sloping land it may be necessary to grade along the contours. Grading involves flattening or "leaning back" a terrace (the slope should go into the hill) so that water soaks into the ground, becoming more available to the trees or crops (see Illus. 6-3). Water in the ground flows more slowly than on the surface, so this method helps to regulate stream water flow and recharge watersheds. An additional method of grading, SALT (Sloping Agricultural Land Technology), is presented in Chapter 7. (For additional information on slope management see "Guidelines for Watershed Management," available from ICE.)

Illus. 6-3. Grading a slope

Figure 1

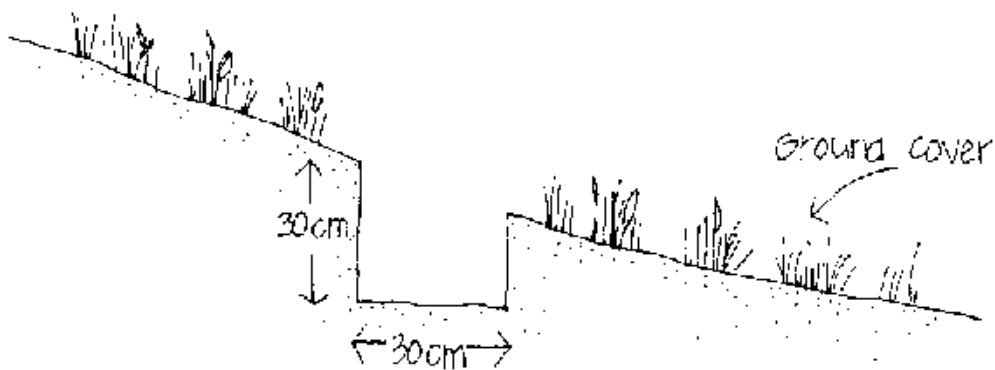

1. Trace out a ditch line along the natural contour of the hill. Dig the ditch 30 cm wide and 30 cm deep. Pile topsoil down slope of the ditch. Use when planting crops.

Figure 2

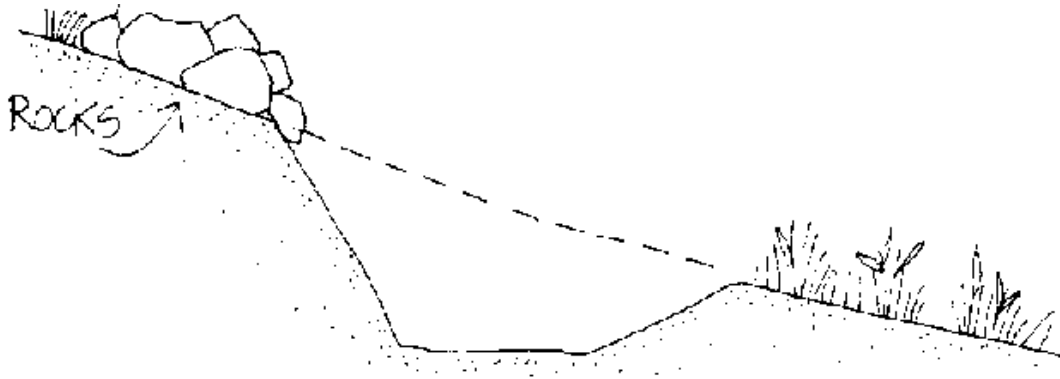

2. Taper the sides of the ditch. Make sure there is a live barrier upslope of the ditch to prevent soil from filling it in. A pile of rocks will serve of similar purpose.

Figure 3

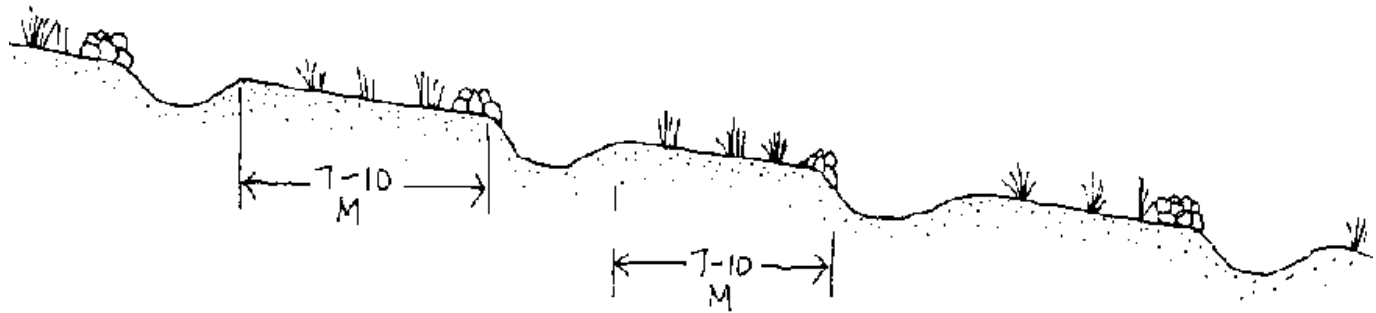

3. Build the ditches every 1 to 10 meters. This can vary with the type of crops planted.

To save time when planting, string out the rows ahead of time (see Illus. 6-4). Use footsteps or a stick to space the holes along the line. With proper spacing, trees grow evenly and productivity is increased.

Illus. 6-4. Lining Out Rows

ILLUS. 6-4  
Lining Out Rows

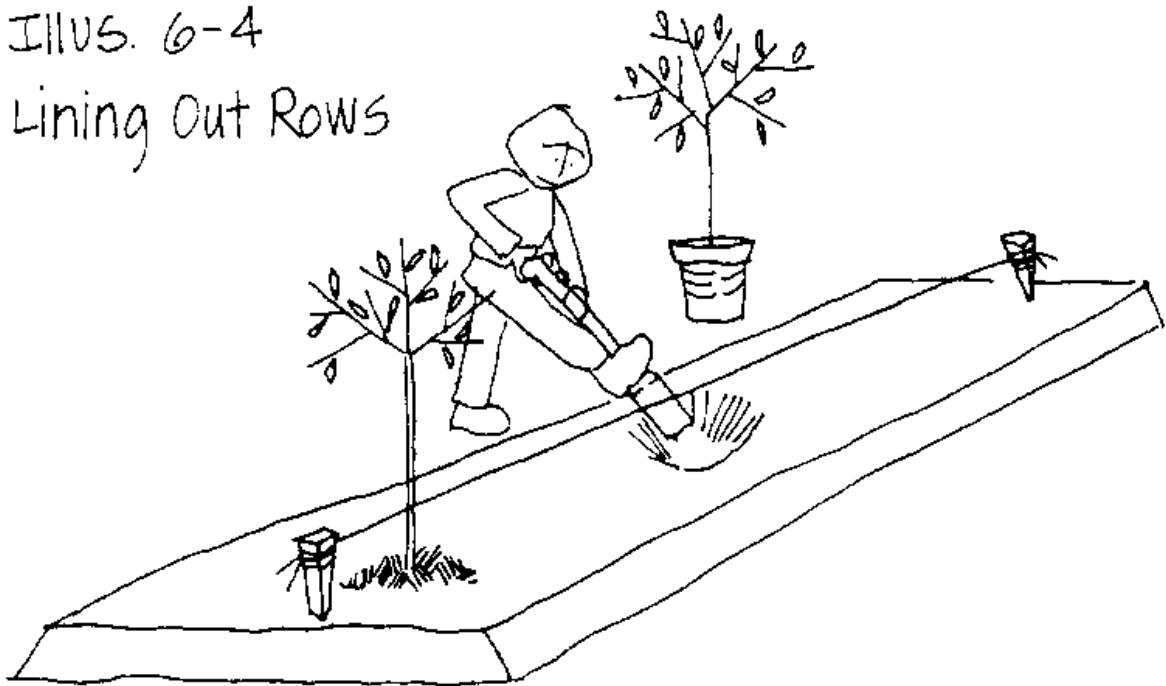

Only after the site is prepared can planting occur. When direct-seeding, scarify the seeds and place them in individual holes or in trenches. If direct-seeding legumes, inoculate the seeds (see Appendix C for how to inoculate seeds). Water them frequently until the seedlings are well established. While watering, remove any weeds that threaten the seedlings. Reseed areas where seeds did not germinate.

Provide enough space for each tree. The area required depends on the type of tree and the desired number of trees per area. Trees grown primarily to control erosion can be planted very close together. Trees grown specifically for firewood or hardwood purposes will need a wider more exact spacing. The following table is a general guide for spacing based on a certain number of trees per hectare. Species-specific information can be found in Appendix C.

Spacing of holes	Trees per Hectare (ha)
2 _ 2 meters	2,500
3 _ 3 meters	1,100

4 _ 4 meters	600
10 _ 10 meters	100

Exact spacing is not necessary, although good spacing is necessary to prevent overcrowding in later stages of growth.

#### *Planting Potted and Open-Rooted Stock*

Planting seedlings from the nursery requires preparing the seedlings, lifting them out from nursery beds and blocks, transporting them, and then planting them so that the soil surrounding them is at the same level as was the soil in the nursery.

To prepare seedlings, harden them for four to six weeks before moving by gradually removing them from shade and reducing the amount of water. This will help accustom seedlings to more variable water supplies. Prior to planting, water them heavily for three to four days. This will ensure that the nursery soil surrounding the seeds is completely moist and will provide adequate water for moving. It will also make removal from pots easier. Avoid waterlogging by making sure that pots do not sit in puddles of water and that drainage is good.

Pots are easy to remove from the nursery. The major concern is the amount of stress from sun and wind during transportation. Transportation for the plants must be timely and dependable. Move plants as quickly as is safely possible to the planting site. Arrange transportation for seedlings well in advance. If possible, outfit the vehicles that will be used with wind and sun guards to minimize plant drying. Water the plants at the nursery immediately before loading and after unloading at the planting site. Shelves in the vehicle will increase the number of pots that can be carried in one trip.

Open-rooted stock require more careful removal. Dig open-rooted stock out slowly and carefully, using a sharp shovel (see Illus. 6-5). Trim roots that are ripped and torn, and shape the roots into a compact structure (see Illus. 6-6). Make a bundle of the open-rooted stock by laying the seedlings down on a long piece of plastic or burlap; wide leaves also suffice. Place the seedlings in the bundle so that the roots point toward the center of the strip, with the shoots extending outside of it. To save space, lay half of the seedlings facing in each direction. Cover the roots with damp soil or mulch, and roll the strip carefully, making sure all of the roots are covered. The bundles can be transported by vehicle or backpacks to the site. At the site, unroll the bundles one at a time so that those still waiting to be planted will remain protected.

**Illus. 6-5. Removing Open-Rooted Stock**

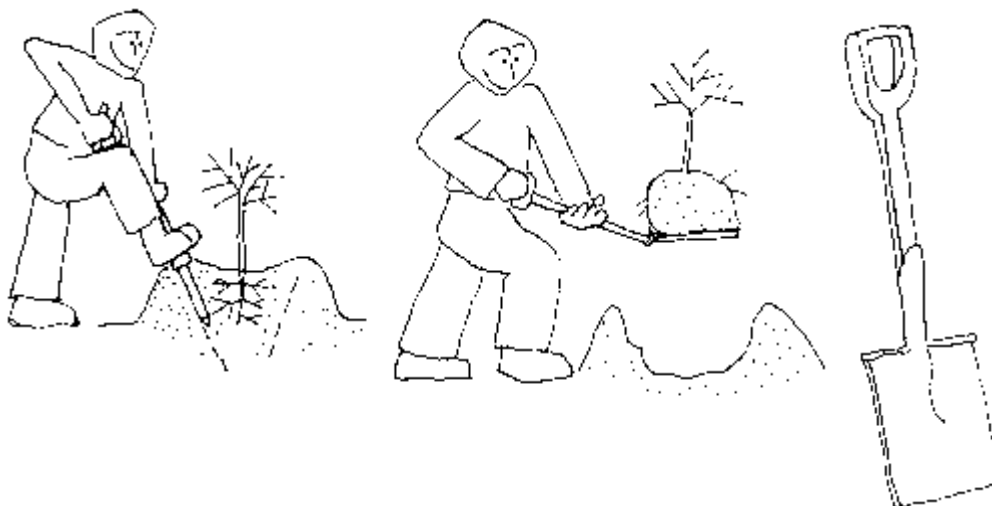

### Illus. 6-6. Trimming Roots

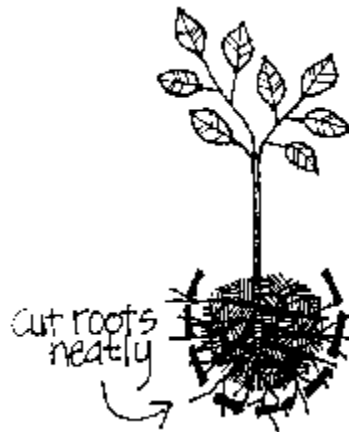

(Weber, 1983)

Some open-rooted stock suffer heavy water losses when removed from the beds. To reduce this loss, remove the lower layers of leaves. For some trees, such as **Gmelina** and **Cassia**, cut off the entire shoot and plant only the root. Regeneration will take place when the root is replanted.

If any long delays occur at the planting site due to labor shortage or other problems, the seedlings will have to be protected from drying. Sink potted seedlings in blocks similar to those in the nursery, to a depth of 5 cm or more in the ground. Water once a day.

Should delays occur during the planting of open-rooted stock, the stock must be **heeled in**, or buried close together, because open-rooted stock are not able to get nutrients or water while rolled in the bundles (see Illus. 6-7). To heel in open-rooted stock, follow these procedures:

1. Dig a trench with angled sides large enough to contain all of the seedlings, and deep enough to cover one-half of the seedlings' shoots.
2. Lay a row of seedlings along the edge of the trench, so that they are leaning at the angle of the side of the trench. Cover them with soil, leaving only one-half of the shoot exposed.
3. Lay another row of seedlings on top of the others and cover them with soil. Repeat until all of the seedlings are covered, then fill in the rest of the trench.
4. Water the seedlings well. Transplant as soon as possible.

### Illus. 6-7. Heeling in open-rooted stock

ILLUS. 6-7 HEELING IN OPEN-ROOTED STOCK

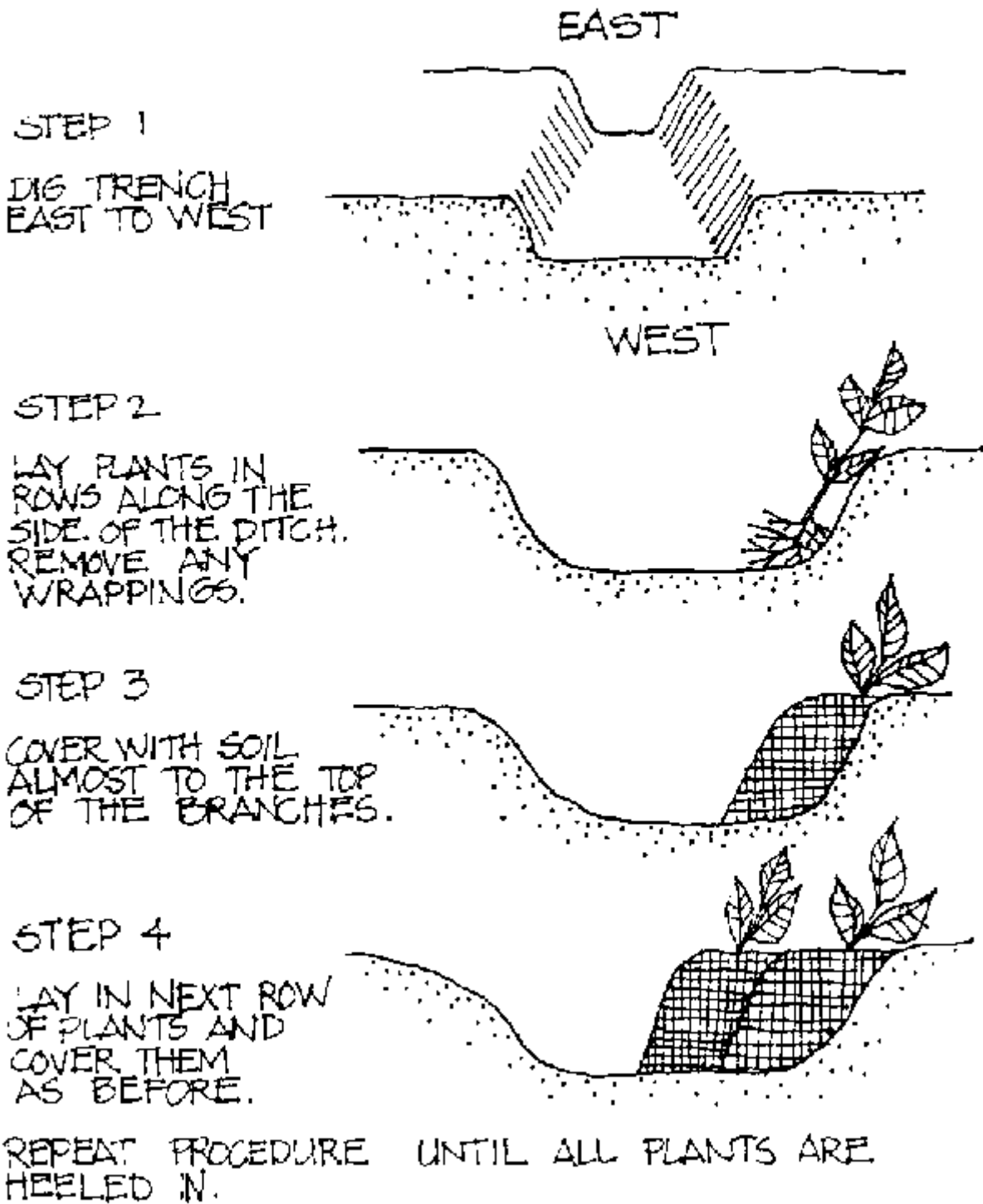

(Weber, 1983)

Open-rooted stock will not last long in the trench before they begin to suffer from competition for water and overcrowding. Heeling in only works for a few days before the seedlings are damaged beyond recovery.

Planting techniques are similar for potted and open-rooted stock (see Illus. 6-8 and 69) To ensure success, plant as soon as possible after transport. Survival rates increase when the seedlings are planted at the same level as in the nursery, and when adequate water is provided.

To prepare the holes, clear all vegetation within a one-meter area of each hole. This will reduce competition for water and increase chances of survival. Dig holes 40 x 40 cm wide. Place the dug-out soil in two piles around the hole. Keep the topsoil separate from the subsoil. The topsoil will be placed near the roots when the hole is refilled. Remove any large rocks that will hinder root growth.

**Illus. 6-8. Planting potted stock**

ILLUS 6-8

PLANTING  
POTTED STOCK

STEP 1

DIG HOLE, PLACING SUBSOIL ON TOP

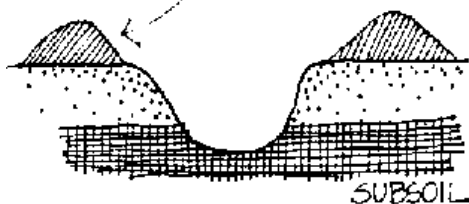

STEP 2

CUT BOTTOM FROM POT

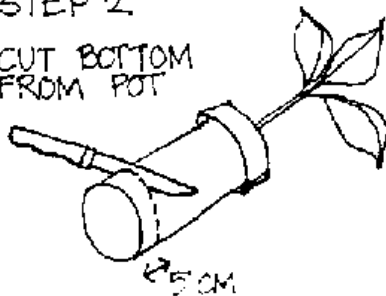

STEP 3

CUT POT LENGTHWISE

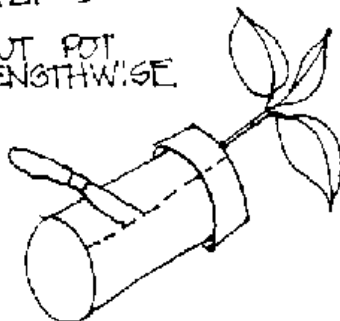

(Weber, 1983)

STEP 4

PLACE POT IN HOLE (HOLD POT TOGETHER WITH HANDS)

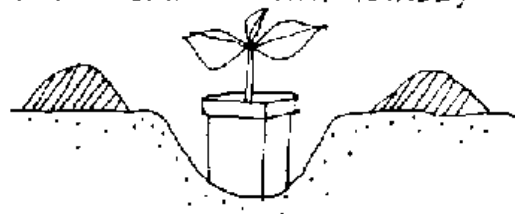

STEP 5

BACKFILL, THEN REMOVE POT

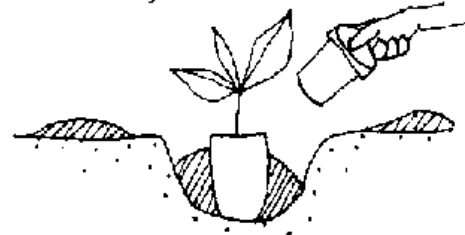

STEP 6

REMOVE AIR POCKETS, PACK SOIL FROM 2 OR 3 DIRECTIONS.

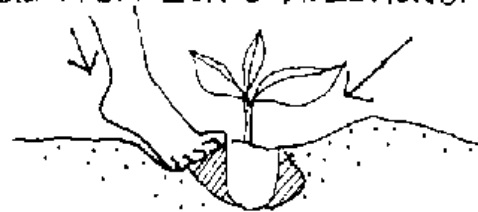

STEP 7

MAKE SLIGHT DEPRESSION AND MULCH IF POSSIBLE.



Illus. 6-9. Planting open rooted stock

ILLUS. 6-9

### PLANTING OPEN ROOTED STOCK

#### STEP 1

CLEAR THE GROUND OF ALL VEGETATION AT THE TREE LOCATION

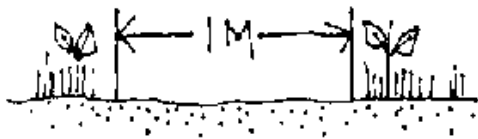

#### STEP 2

DIG HOLE, PLACING SUBSOIL ON TOP

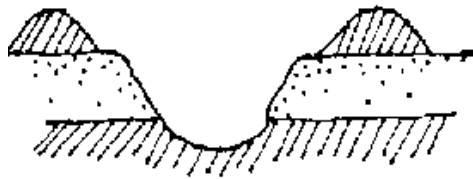

#### STEP 3

HOLD TREE ABOUT 3 CM BELOW ITS FINAL POSITION.

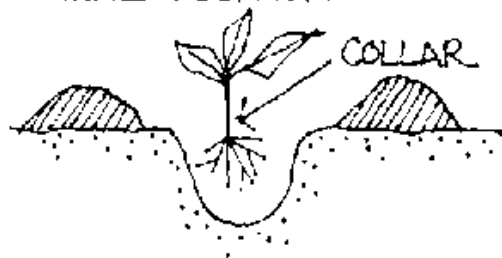

#### STEP 4

RAISE TREE TO FINAL POSITION AFTER SOME SOIL HAS BEEN PLACED AROUND ROOTS.



#### STEP 5

REMOVE AIR POCKETS. PACK SOIL WITH FOOT FROM 2 OR 3 DIRECTIONS.



#### STEP 6

MAKE SLIGHT DEPRESSION. MULCH WHERE POSSIBLE.



(Weber, 1983)

To plant nursery stock, follow this procedure:

1. Remove potted plants by turning the pot upside down and slowly letting the roots and soil slide out. Do not pull strongly on the plant or grasp the leaves firmly, as bruising may create an environment for disease. It is best to handle the plant by the leaves rather than the stem. For

plastic bags, cut around the bottom of the bag and then open it with one long horizontal cut all the way to the top. It may be possible to slide the plant out and reuse the bag. Remove open-rooted stock by slowly unrolling the bundle. Don't expose seedlings to the hot sun just before they are placed in the ground.

2. Place the seedling and the soil surrounding it in the hole so that the **collar** of the seedling is at the same level as it was in the nursery. (The collar is the point where the stem met the soil in the pot or the seed bed. This point is often visible by the first small roots on the stem.) Make sure all workers can identify the collar as the original soil height; otherwise roots that should be buried may be left exposed. Errors in placement will adversely affect the productivity of the seedlings.

3. Space the roots out as evenly as possible without damaging them. If compost is available, place a handful in the bottom of each hole. Backfill the hole halfway and tamp the soil all around the seedling. Finish backfilling and tamp again. This removes large air pockets which would dry out the roots.

4. Grade the top layer of the soil so that water flows toward the stem. Keep the soil loose and friable.

5. Water the seedling well, but slowly, allowing the water to sink in. Do not water too strongly, as it will displace the soil or quickly runoff. **Do not tamp the soil after watering.** If the soil is tamped after watering it will be compacted when it dries, preventing both water and air from entering it.

6. If mulch is available and the soils are not naturally waterlogged, place it around the tree to prevent water loss and keep the soil rich, loose, and friable. Green manure can be used to provide nutrients.

7. If the planting was timed properly, the rains will provide adequate water. Timing is crucial to survival; in arid areas, rain within the first day of planting can increase the survival rate to 90%. The lack of rain for two to three days will decrease the rate to 30%. If timing was poor or the rains fail, bring water to the site frequently to assure survival and root development. Only water the area immediately around the plant, and mulch heavily. To survive dry periods, plants must have well-developed root systems to absorb and store hard-to-reach water. If mulching during periods of extended, heavy rains, leave a space between the stem of the tree and the mulch to prevent rotting.

### *Direct Sowing*

Direct sowing at the site is the method used for species with high germination and survival rates, and for species that require less care than other plants. It is normally recommended for projects utilizing a fast-growing legume for erosion control, intercropping, or fuelwood purposes. Direct sowing is much faster and less expensive than planting seedlings raised in a nursery.

For **intercropping** and **erosion contra**, plant seeds as in nursery beds. Space rows depending on the use of the area. If intercropping trees with food crops, plant and maintain trees so light reaches the crops. Plant to avoid competition. It is also important to provide enough space so that farmers can cultivate the area with whatever tools or animals they have. Provide enough space for future plans as well. For instance, a corn Leucaena intercrop may eventually be replaced with a Leucaena-fruit tree intercrop.

It is necessary to thin directly sown seedlings in order to reduce competition between plants. The spacing is determined by the needs of the plant, the germination rates of individual species, and the objective of the project. If the objective is erosion control, or fertilizer and feed production, rather than timber, seedlings require minimal space. A legume such as Leucaena only requires 5 cm between hills. For fruit, hardwood, and firewood programs, remove all of the seedlings except the most vigorous one from the hole. Be careful not to damage the remaining seedling when removing the others. (For additional information on planting and maintaining a site, see "Establishment Techniques for Forest Plantations," available from ICE, and Appendix C for spacing requirements of selected species).



If water is available, water regularly. If not, only plant during the rainy season. Plants require more water in the field than in the nursery because of the effects of sun and wind.

### Site Maintenance

After a plantation or individual site is planted, the trees and supporting systems must be protected and maintained by reducing competition from weeds, pruning, thinning, keeping pests and diseases in check, and maintaining structures such as fences, firebreaks, windbreaks, and roads.

#### *Weeding*

Weeding within a meter of seedlings reduces competition for water and sun. Avoid damaging seedling roots when pulling or digging weeds. Beyond a meter, weed cover can be used to protect the soil from erosion, provided that the weed species grows low to the ground and requires little water. Grasses generally fit these requirements. If the trees are protected with fencing, etc., livestock can be grazed on the grasses. As the trees form a canopy, they will outcompete the weeds.

Another way to reduce competition from weeds is to encourage local farmers to cultivate the land until the trees mature. This **Taungya** system is a useful way to provide people with a means to increase their food output for a several years while keeping weeds at bay. Encourage farmers to plant crops such as legumes that provide nutrients to the soil. These can be intercropped with a staple such as corn. Avoid planting in succession crops that are heavy feeders, as this may limit the growth of the seedlings due to increased competition for available nutrients. If mulch is available, mulch the weeded area. Warn staff and farmers against damaging the young seedlings when plowing or weeding. Make it clear that as the trees mature it will be difficult to plant crops such as corn or upland rice. (See Illus. 6-10.)

Illus. 6-10. Farmer working between rows of trees

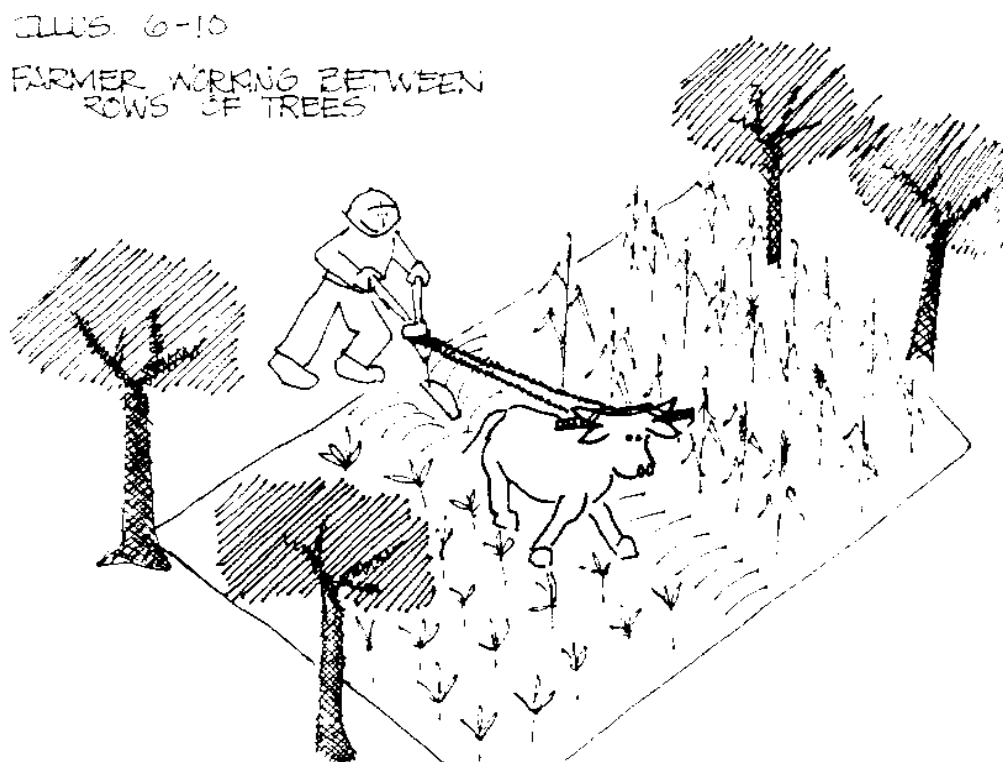

#### *Pruning*

At older fuelwood, timber, and fruit tree operations, quality of product and overall productivity is increased by pruning. Consult available records to determine the age and history of the stand. Knowing the age of the stand will help determine the time to prune. The history will provide valuable information on fertilization, diseases, etc. If possible, consult the person responsible for planting the stand.

Pruning is done for one of many reasons:

- To remove dead or injured members. This should be done any time dead or injured parts of a plant are visible.
- To check the growth of plants where space is limited.
- To thin plants that have become too dense to admit light and air to the areas in which they have planted, or plants on which interior branches, leaves, and fruit do not receive enough light.
- To encourage root growth and to prevent dieback of the branches.
- To rehabilitate trees that suffer from neglect, poor growing conditions, or diseased parts.
- To encourage fruit, wood, or foliage production, or to stimulate the growth of larger branches and fruit.

Pruned branches and whole trees can also provide firewood for local industries and households. The major disadvantages to pruning are the decrease in growth rate of trees and the amount of labor. Weigh the pros and cons. Pruning coffee trees will prove to be advantageous due to increased output, yet it may not be advantageous to prune a stand planted specifically for village fuelwood consumption.

If pruning is desirable, the schedule for pruning will depend on the type of trees, their growth rate in the area, and economic considerations. Some pruning can be done at any time suitable to the forester or farmer, while other pruning must be done during a specific time of year. As mentioned, past records will be invaluable in determining the history of the stand, especially for growth rates and any previous pruning. For this reason it is important to make accurate records of activities and schedules, and include procedural advice for the next community forester such as expected dates for pruning. A typical schedule will look something like this:

<u>Pruning period</u>	<u>Age of stand</u>
1st	6-7 years
2nd	8-9 years
3rd	10 -12 years

Actual schedules will depend on the tree type and local conditions.

Most pruning takes place close to the ground, but occasionally higher branches must be felled. The best tools for pruning are clippers, saws (separate and fixed on long poles), and ladders. Large limbs should be undercut away from the trunk first, then cut above to fell them (see Illus. 6-11). This will prevent the bark of the tree from being stripped off, which exposes the tree to disease. Finish by cutting the limb flush to the trunk. Smaller branches can be cut flush with one cut.

Illus. 6-11. Pruning

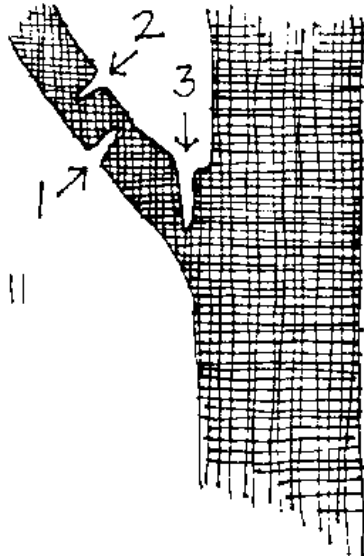

ILLUS. 6-11  
Pruning

Fruit trees should always be pruned. Pruning is carried out when the tree is dormant, normally during the dry season. When fruit trees are pruned, nutrients that would have gone to make leaves and branches are redirected to produce fruit, increasing yields. All "suckers"- the single -year shoots which have grown straight up from lateral branches - should be removed.

The rule to follow is "a space for every limb and a limb for every space." This rule is followed while developing the shape of the tree. This assures even spacing of limbs and adequate sunlight for fruit development. Remember that each type of fruit tree (and each individual tree) has different pruning requirements in terms of techniques used and desirable final shape of tree.

#### *Thinning*

Thinning of stands is carried out to remove dead and diseased trees, to allow faster-growing trees more room to grow, and to provide products that generate steady income. Like pruning, thinning should be carried out only when it is economically feasible. Costs of thinning are estimated on the basis of the following requisite steps:

Marking trees for cutting. Trees to be cut should be marked by personnel qualified in selecting suitable trees and in removal techniques.

Falling and bucking. Trees marked are felled and removed from the stump. The branches are stripped or cut off.

Yarding and loading. Trees are moved and loaded. To minimize costs, wood should be loaded within at least 200 m of felling activities.

Transport to market. This will be the greatest cost, involving fuel and vehicle maintenance. Attempt to find markets close to the stand.

Administration. Administration involves various costs of paperwork, other labor, and supply costs.

Costs can be reduced by using manual methods for cutting and animals for yarding. However, these simpler techniques will increase the time needed to complete the operation. This must be considered when promising availability to customers. Timely shipment is not a concern if the intention of the project is to provide products for local consumption.

Selection of trees is all- important to thinning operations. Consider the space requirements for the individual species and the soil characteristics of the site. Consider the position of trees in the stand and the need for openings for lateral branch growth. Generally, the ideal state is one in which the crowns of the trees touch without crowding and fully cover the ground. This is especially true of trees grown for maximum timber and fuelwood production, and it is less true for fruit tree production. Fruit trees should be thinned so none of the trees overlap. If the program is designed to control soil erosion, thinning need not be a priority.

When thinning, leave the strongest, healthiest trees and remove sick, weak, or defective trees. Defects include rot, top breakage, and forks and crooks in the trunk. For frequency of cutting, consider the space needs of crowns and roots. Removal can be carried out systematically by either cutting every other tree in a row or by cutting all the trees in every other row.

### *Harvest Planning*

Harvesting is the final part of a forestry cycle. When to harvest a site depends on many factors: the product, effects on the community, maturity of stand, and market price, among others.

Carry out harvesting procedures in such a way as to limit environmental impact. Remember that the community is to be the major benefactor of any harvest. Plan carefully the methods and areas to be harvested so that slopes are not exposed to erosion and the watershed recharge is not reduced. Be willing to forego the harvest of a stand if the benefits to the community (products and money) will not outweigh the costs, such as loss in services. Avoid removing from sites trees that are needed for soil conservation and watershed recharge. Consider leaving trees at the edges of the site for erosion control, water production, windbreaks, and wildlife habitat.

Different products require different harvesting strategies. Products such as fruit, resins, and green manure are harvested throughout the lifetime of the tree. Fuelwood, poles, sawlogs, and pulp are harvested at the end of the tree's life.

Harvest fruit for local consumption when it is ripe. When the market is far away, harvest fruit before ripening, provided the fruit will continue to ripen off the tree. If farmers are provided with appropriate fruit trees and instructed in their care, they will be able to determine the best harvesting time by themselves. Give additional instruction in handling and storage techniques to increase the quantity of fruit available to farmers and their families.

The leaves of most green manure and fodder species can be harvested after the plant reaches one meter in height. One method of harvesting is to top the tree to a desired height like a hedge. This is normally practiced when intercropping food crops with trees. Another method is to harvest individual branches, then strip them of leaves. The advantage of the former method is the ability to intercrop, as well as ease of harvest. In the latter method, the trees will often grow tall and make harvesting more difficult. Regardless of the method chosen, in order to sustain growth it is necessary to leave at least one-third of the leaves on the plant. Be aware that certain species will only coppice readily for a certain number of years and then must be replaced with a new tree.

When planted for local consumption, fuelwood species can be harvested as fuelwood is required. Since most species coppice well for a number of years, and thus can produce a sustained yield, it is recommended to harvest portions of the trees rather than whole trees. (For additional information on harvesting of fuelwood species for maximum yield, see "Firewood Crops: Shrub and Tree Species for Energy Production," available from ICE.)

Trees are harvested for poles when the diameter desired (based on the end use of the pole) is attained. Select poles for soundness, straightness, and gradual taper. Harvest bent, diseased, or uneven poles for use as fuelwood. Treat poles that are to be used in exposed places against rot and termites. (For additional information of harvesting trees for wood products, see "Firewood Crops: Shrub and Tree Species for Energy Production," available from ICE .)

When harvesting for wood products, consider economic and biological factors. From an economic point of view, trees should be harvested when profit is maximized - when returns from selling the wood minus costs of growing and harvesting it are the greatest. Sometimes the age at which profit is maximized is less than the desirable biological age of rotation, or harvest. Money should not be the only determining factor when considering an appropriate time to harvest. The need for trees and services, availability of labor, and existing markets must also be considered.

Biological considerations are also important in determining the appropriate time to harvest. As with green manures, other species should be allowed to reach a minimum size before they are coppiced or harvested whole. Failure to do so may result in a yield lower than expected over the lifetime of the tree. As trees age they become more susceptible to infestation and disease. Early harvesting may be necessary when disease and pests threaten to leave nothing worth harvesting. As mentioned, certain

fuelwood species will only coppice for a number of years before production is reduced. Other considerations include seed production, the durability of the soil, and the emergence of competitive species.

Foresters consider the optimum biological time (also known as the rotation age) to harvest fuelwood, sawlogs, and pulpwood to be the point when the average growth rate of the trees slows down. Growth is measured by changes in the volume of the tree. To determine the volume of a stand, the overall area of the stand must be known. A cruise stick or similar device is needed to measure a tree's diameter at breast height (DBH, measured 1.3 m from the ground) and its overall height. These measurements are used with volume tables for the species being measured.

### *Harvesting Methods*

Harvesting requires skill, tools, knowledge, and equipment in order to do a complete, environmentally sound job.

Axes, saws, wedges, and sledges are all that are needed for harvesting in most cases. Avoid using chain saws for small operations. They are expensive to purchase and operate.

To fell a tree, make a direction cut at right angles to the desired direction of the fall with an axe. This cut should be a wedge 1/5 to 1/4 of the thickness of the tree depth. On the other side of the tree, parallel to the first direction cut and a little bit above it, make another cut until the tree leans over and falls. An axe can be used for this cut, but saws are faster. Wedges can be placed behind the saw to keep the cut from closing on the saw and crimping it. When planning the direction of the fall, consider the balance of the crown, the clearance, and the risk of damage if the tree falls in an unwanted direction. Remember: it takes a lot of practice to land a tree where it is supposed to go. Learn on small ones.

After felling, remove branches and cut trees into desired lengths. Haul them to a loading point within easy carrying distance.

In many areas of the Pacific, farmers are in the habit of felling trees with fire. This should be discouraged for the simple reason that a good portion of the tree becomes unusable, and uncontrolled fires have the potential of destroying vast forested areas.

### **Site Protection**

Protection is an important component of site management. Various threats to the productivity of a site include diseases and pests, animals, wind, fire, and damage caused by humans.

#### *Disease and Pest Control*

The risk of damage from pests and disease is greater if the trees are weakened by poor planting methods, poor site selection, preparation, and maintenance, and adverse soil and climatic conditions for the species being used. Choose species suitable to the site and use genetically resistant strains when possible. Maintain young trees to ensure good health throughout the life of the stand. Manage the site to reduce the exposure of trees to stress (such as fire), which will lower resistance.

Diseases and pests, such as insects, must be brought under control as quickly as possible or they may destroy most of the project. Inspect plantations and farmers' trees frequently for signs of disease, such as spotting or yellowing of leaves, rot, rust, root or stem weakness or decay, and any other symptom of damage. Insect damage will show up as chewed leaves (defoliators) or damage to seeds and fruits (borers). Isolate damaged plants or their parts by removing and destroying them. Identify pests as quickly as possible and enact necessary controls.

The types of controls available for pests are silvicultural, biological, mechanical, and chemical.

**Silvicultural controls** include well-timed and careful thinnings, which eliminate the weak and diseased stems that act as vectors for diseases and pests, in turn reducing the threat of an attack. Following removal, burn the thinnings to ensure destruction.

Integrating different species on one plot is another silvicultural control which makes it difficult for pests to spread across the entire stand. Plant species that attract different insects and diseases. Also, interplant species that attract predatory insects.

**Biological controls** are complicated and not yet well developed, but are less environmentally damaging than chemical controls. The types of biological controls include the introduction of predator species that feed on harmful insects. In addition to insect predators, there are pathogens that usually work by entering insects through the mouth and then multiplying in the bloodstream. Be careful not to destroy natural predators by introducing chemical pesticides. Beneficial insects and pathogens are often more susceptible than pests to toxic chemicals.

Traps are another way to destroy harmful insects. Sticky substances placed in a band around tree trunks stop crawling insects. Sweet liquid placed in a container will attract then drown harmful pests. Hollow poles resembling habitats draw some insects and allow easy collection and destruction.

**Mechanical controls** involve physically removing or destroying pests or their hosts. Litter removal and cleaning are effective mechanical controls if the pest spends part of its life in humus or detritus. Tree traps, which are constructed by cutting a tree, stripping its bark for easy insect entrance, and placing it across a row of trees, are another way to control pests. Large numbers of certain types of pests will enter the tree trap and leave the other trees alone. Then simply remove and burn the trap before the larvae of the pest emerge. For this method to work, the life history of the pest must be well known and the practice well tested on it.

**Chemical controls** should be used as a last resort because of their danger to the environment and their great cost. Chemical controls may be difficult to use safely, and it may be hard to properly instruct workers on their use. Consider the effects of chemical controls on yourself, workers, and the local environment before using them. Effects on the water supply must be carefully gauged, as chemicals can cause deleterious long-term problems. When using insecticides, herbicides, or fungicides, follow safety procedures strictly and dispose of residues properly (see Appendix F). Other controls to be considered include natural insecticides (such as those derived from the fruit of the neem tree, *Azadirachta indica*). Local experts and farmers should be consulted on local treatments for insect and disease problems.

### *Animal Problems*

Crop damage can be caused by both domestic livestock and wild animals. With a large project, this is almost impossible to control. If possible, erect fences around individual trees or the entire area to control animal intrusion. Construct fences with spacing between wires or sticks small enough to prevent entry by the smallest animal which could cause a problem. Maintain the fence regularly to prevent holes, a single hole can negate the effects of the entire fence.

If livestock intrusion is a serious problem, work out an agreement with the owner of the intruding animals that is favorable to both parties. Attempt to obtain another parcel of land for the owner.

Wild animals are more difficult to control because they are smaller and less visible. Individual fences of thorny material surrounding young plants may be necessary to keep rats, ravens, fruit bats, and other animals away. Fruit trees are especially vulnerable to predation, and constant observance during fruit ripening season is necessary in areas where birds and other predators are abundant. Nets or bags are often placed around individual fruits to repel fruit bats and climbing predators.

### *Wind*

Wind can dry out seedlings, blow away exposed topsoil, and deposit unwanted sand and dust. Small **windbreaks** can be constructed of local materials, or a **shelterbelt** can be planted at right angles to the prevailing wind. Both methods affect air movement in such a manner that there is a slowing down in wind velocity as winds approach the break, even before the break is reached. The diminution of the wind starts a chain of favorable climatic influences, such as the reduction of evaporation, the lowering of temperature, the increasing of relative humidity in the air - all of which result in an increase of crops grown under the protective influence of shelterbelts.

The design of a shelterbelt is determined by the project. Normally, shelterbelts are many-rowed plantings with short bushes on the outside and higher-growing trees to the inside. Plantings are

alternated between rows to minimize gaps. The effect, in cross section, is a delta-shaped arrangement that halts the wind in the lee and reduces wind speed nearby. Do not plant a shelterbelt too near the project it is designed to protect. Close plantings will rob plants of moisture and nutrients.

Prepare the soil as in any other planting project. Plow, add essential nutrients, and plant. Trees can be grown from seeds or transplants. Shelterbelts must be initiated long before transplanting if they are to be mature and in place when needed. Plant at the outset of the rainy season if water is a problem.

Holes must be repaired in windbreaks and shelterbelts, as they concentrate the wind and its effects by funneling action. Avoid this problem by having paths cross shelterbelts obliquely and by using gates on windbreaks.

Shelterbelts can also be less formal. Trees of uniform height can be planted in one row, or several rows deep. Grow directly from seed for quick emergence. Choose a species that is hardy and requires minimal maintenance.

If carefully planned, shelterbelts can also be a good source of seeds for a nursery or field project.

### *Fire*

Fire is used in many areas to clear land for agriculture and to invigorate grasslands for grazing. Fires can be a threat, however, if they get out of control or are misdirected toward a planting site. Factors that affect burning and should be understood by the forester are fuels, wind, moisture, temperature, and slope. (For additional information on fires and fighting fires, see the "Fireman's Handbook," United States Department of Agriculture, Forest Service, FSH 5109.12.)

Fuels are commonly divided into two main groups: light and fast-burning fuels make up one group - dead grass, dry leaves, and tree needles, brush, and small trees. Light fuels cause rapid spread of fire and serve as kindling for heavier fuels. Some green fuels such as tree needles have a high oil content and are fast-burning when they are not in the active growing stage. Heavy or slow-burning fuels are composed of logs, stumps, and branch wood. Dry, heavy fuels burn readily and produce large amounts of heat.

The stronger the wind, the faster the spread of fire. This is true because wind brings an additional supply of oxygen to the fire, directs the heat toward the fuel ahead, and causes spot fires by blowing sparks and embers from the main fire into new fuel.

Fire itself causes local air currents that add to the effect of the prevailing wind in the fire spread. The air above the flame becomes heated and rises, then fresh air rushes in and helps the burning. Generally, the wind is gentlest from 0400 to 0700. As the heat from the sun warms the ground, the air next to the ground is heated and rises. Air currents thus usually flow up mountains and slopes during the day. During the evening and night, the ground cools and the air currents reverse their direction and flow down mountains and slopes. It is important to remember the direction of slope wind flow when planning the attack on a fire.

Moisture in the form of water vapor is always present in the air. The amount of moisture in the air affects the amount that is in the fuel. The moisture content of fuel is always an important consideration in firefighting since wet fuels, and most green fuels, will not burn freely. Air is usually drier during the day than it is at night. Fires thus burn more slowly at night, under normal circumstances, because moisture is absorbed by the fuels from the damper night air. (See Illus. 6-12).

Illus. 6-12. Periods of fire hazard

ILLUS. 6-12  
PERIODS OF  
FIRE HAZARD

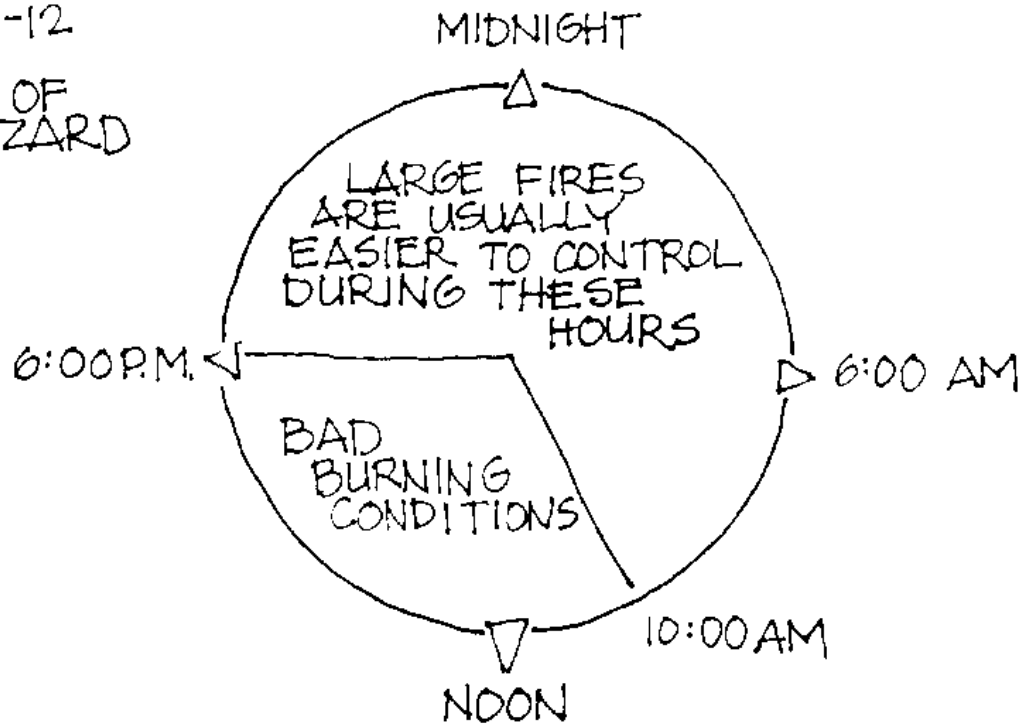

Absorption of moisture by the fuels, downslope winds, lower temperatures, and day-night weather differences generally aid the firefighter at night. This is why a fire may burn out of control in the afternoon and yet may be contained by the same crew at night. Every effort should be made to completely surround and control a fire before bad burning conditions build up the following day.

Air temperature affects firefighting. Fuels preheated by the sun burn more rapidly than do cold fuels. Temperature will also have an effect upon firefighters.

As well as its wind effect, slope greatly influences the spread of fire by preheating and draft (see Illus. 6-13). A fire will run faster uphill than downhill if the wind is not strong enough to influence the spread. On the uphill side the flames are closer to the fuel. This causes preheating and faster ignition. Heat rises along the slope causes a draft, which further increases the rate of spread. For this reason, it is important not to get caught upslope of a fire.

Illus. 6-13. Slope and fire



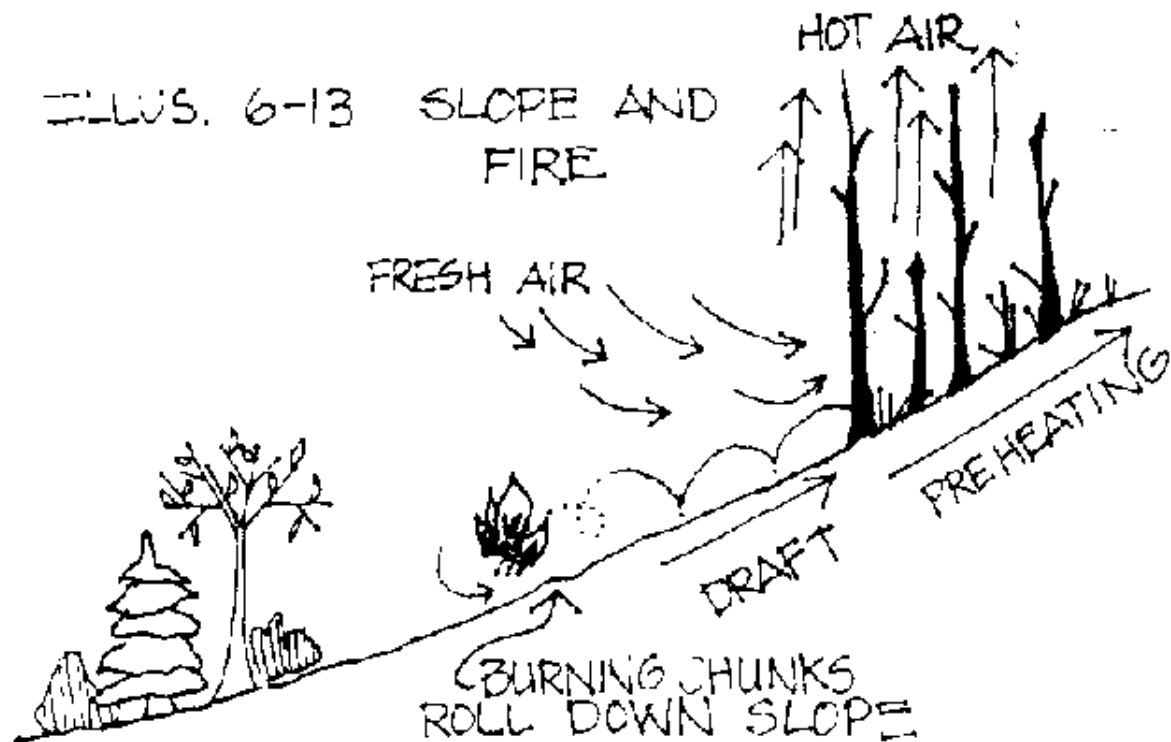

(after U.S. Department of Agriculture,  
n.d., FSH 5109.12.)

Fire controls include firebreaks, controlled burning, and removal of forest litter and weeds, which can act as fuel in a fire. Firebreaks and removal of litter are the recommended method for inexperienced crews fighting fires.

The first step in fighting small fires is to cool down the flames with dirt or water. Follow up this temporary measure by putting in a fireline to the depth of mineral soil. Cut off the fire from the most dangerous fuels as a first effort, and prevent the fire from becoming established in explosive types of fuels, such as thickets of tree seedlings, heavy brush, and areas slashed for use as farmland.

**Firelines** should be constructed a considerable distance from the fire. This gives fighters time to establish a proper line. Remove all rollable or unburned material near the line. This will help prevent fire from spreading into unburned areas. It is easier to construct the line in open cover. Make the line as short as possible and avoid sharp angles in line, where the topography allows (see Illus. 6-14). Block off high-hazard fuels where possible by leaving them outside the fireline. Dig the fireline deep enough to cut tree roots. It is usually safer to construct the line upslope from the head of the fire. This minimizes the danger of the fire crossing the slope below the firefighters and sweeping up to trap them. On the other hand, if the fire is on one side of a narrow ravine, construct the line on the opposite side of the ravine and work up the flank of the slope above the head of the fire (see Illus. 6-15).

**Illus. 6-14. Fireline**

ILLUS. 6-14 FIRELINE

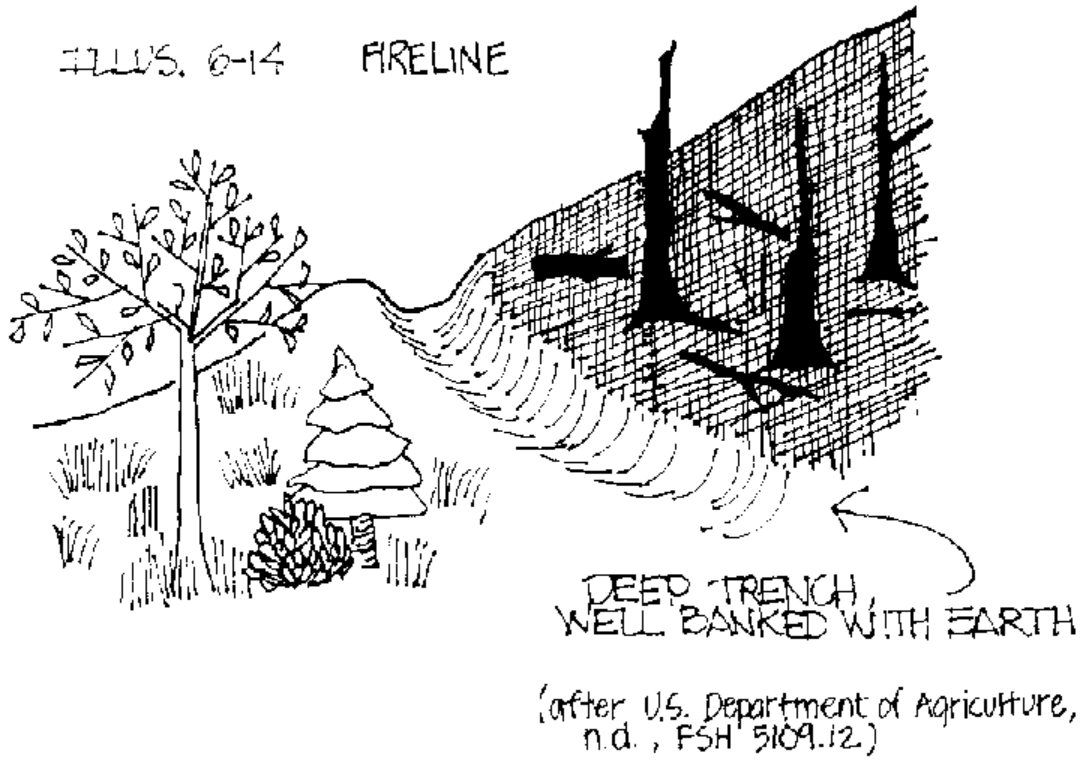

Illus. 6-15. Fireline

ILLUS. 6-15 FIRELINE

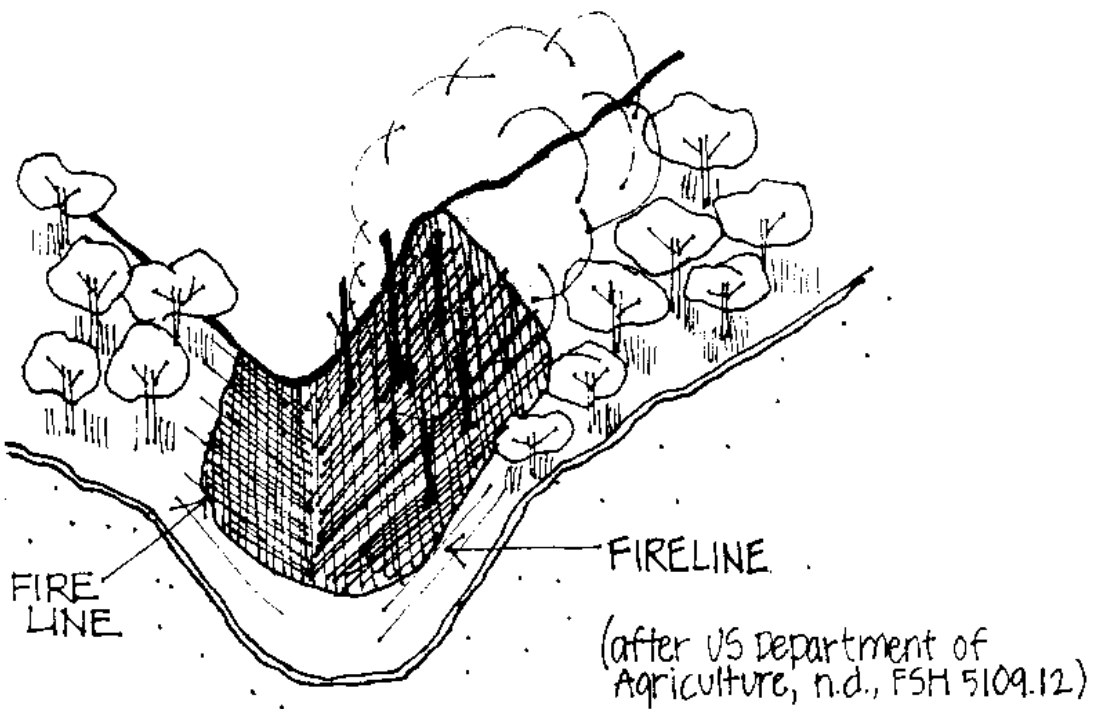

The width of the line is dependent on the type of fuel, slope, weather, and the part of the fire to be controlled. Generally, with hot fuels, steep slopes, and hot, dry weather, wide firelines are necessary.

Since a fire burns hottest at the head, not as hot on the flanks, and with the least heat at the rear, the widest line should be at the head. An average width is 7-15 m.

**Backburning**, or building backfires, is a technique that can halt a fire by eliminating fuel from its path. Build a small, controlled fire in the path of the major fire, within 100 m of the head. Burn along a line similar to a firebreak, 7-15 m in width. The area must have limited growth and litter, or the backfire will get out of control and add to the other fire. If the backfire is built correctly, the large fire will run out of fuel when it reaches the area burned by the backfire.

**Only properly trained and experienced crews should carry out backburning.** Make sure crews have had dry runs of techniques and understand the principles and dangers involved.

After the fire is brought under control and limited in size, mopping-up operations are essential. Water any smoldering areas or branches, and rake them into a single area to isolate them. Carry out mopping-up exercises from the outer limits of the fire inward, until all areas are extinguished.

**Controlled burning** is a method of cleaning the forest of litter that would feed a fire. It can only be carried out in mature stands of trees with fire-resistant bark. Controlled burning requires well-trained crews and good equipment. **This should not be undertaken by inexperienced personnel.**

The procedure is to let small fires burn the undergrowth and dead materials in the forest. The small fires are carefully tended and directed, so that no tree is exposed for very long. The following conditions must be prevalent for controlled burning to be carried out:

- Test fires must not burn faster than 60 cm/min
- Wind must be calm, or under 8 km/hr.
- Relative humidity must be greater than 35%

Controlled burning should be performed late in the wet season to remove litter for the coming dry periods, when the threat of fire is greatest. It should also occur at night, when the relative humidity is greatest. Grasses, especially tall grasses, must be burned before they dry

**Cleaning** the forest floor is another method of denying fuel to possible fires. Organize people to collect fallen branches for use as firewood. Litter should be raked into piles to be carried to a compost or trash pile. It can also be raked into piles for burning. Although this cleaning method takes more time and labor than controlled burning, it is safer

If the reforestation project is large, it should have a fire control plan and trained crews. Assess the danger of fire every day and make the community aware of the level of fire risk, especially during dry seasons. Enlist the community in fire detection by asking people to report any fires in the area. The best firefighting technique is prevention. Educate local people on the need to protect forests and to use safe burning techniques in their areas.

Fires need heat, oxygen, and fuel to keep going. Firefighting and fire controls involve removing one or more of these from the fire, thus extinguishing it. Removing oxygen or heat is possible for small fires by using water, or beating the flames out with brooms, mats, and sticks. For larger fires, removing fuel is the only method feasible.

## **7. Agroforestry strategies for the community forester**

Agroforestry is a sustainable land management system that integrates the production of crops and forest plants and/or animals simultaneously or sequentially, on the same land. Agroforestry applies management practices that are compatible with the cultural practices of the local population, with the intent of increasing the overall yield of land through production of a variety of products, improving the local standard of living, and improving or protecting the quality of the environment.

Agroforestry techniques provide for the use of trees in traditional ways such as timber, fuelwood, and fruit farming. They also encourage new uses: intercropping nitrogen-fixing trees (NFTs) with agricultural crops, creating sustainable, year-round food production, and controlling soil erosion. Useful introductory references include Combe, 1982; Fillion and Weeks, 1984; King, 1980; Mongi, 1975; and Spurgeon, 1979.

Some agroforestry systems have been in place for thousands of years. Most, however, have relied on shifting cultivation (**swidden agriculture**) techniques and are therefore not sustainable over long periods of time in the same location. Traditional systems have also rarely incorporated fast growing NFT species, which offer many advantages over other types of trees. (See ICE Manual FC046; Haines and DeBell, 1979; and NAS, 1977, for details on NFTs.)

Most NFTs used are members of the legume family, often of the genus Mimoseae. Results from controlled experiments and field tests with NFTs in mixed agricultural systems have demonstrated that the overall productivity of the mixed system can be increased over that of traditional cropping or forestry systems alone. Of course, the agroforestry species mix must be carefully selected, proper care taken, and maintenance procedures followed.

The ability of certain trees to fix nitrogen is key to the success of many agroforestry projects. Nitrogen is abundant in the atmosphere, but not in a form readily usable by plants. NFTs fix nitrogen through the action of Rhizobia bacteria, which infect root hairs and remain in root nodules (see Illus. 7-1). The Rhizobia are capable of fixing atmospheric nitrogen and then releasing it to the plant in a usable form. The plant absorbs the nitrogen, and some is incorporated into the leaves. Fallen leaves can then be collected and used as mulch to provide nitrogen to crops or as a protein rich fodder for livestock. Of the nitrogen in the leaves, 60% is generally lost to the air (though renitrification) or washed into streams. The other 40% is available as green manure to crops. This quantity is adequate to provide all of the nitrogen needs of most crops and is sufficient to increase yields by 89-100% (in controlled tests).

Illus. 7-1. Rhizobia nodules

### ILLUS. 7-1 RHIZOBIA NODULES

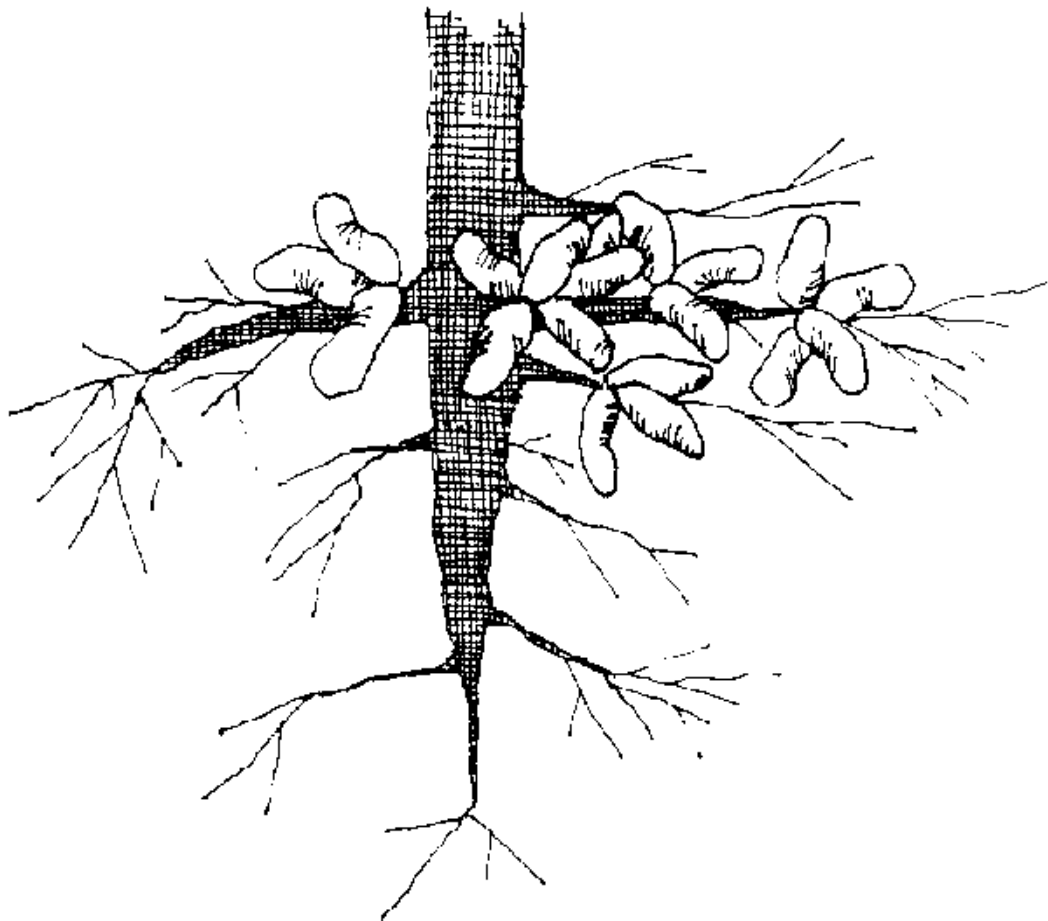

For NFTs to be effective, the correct Rhizobia strain must be available, healthy, and vigorous. The presence of healthy Rhizobia is indicated by bright red nodules. White nodules indicate an absence or an inadequate number of Rhizobia colonies.

Inoculants can be obtained from extension agents or the forestry service. If necessary, they can be grown in a laboratory using only basic equipment and simple culturing techniques. If lab culture is not possible, soil can be taken from the area around healthy stands of the same tree species that have active nodules. This soil can be used to treat seeds and other soil to initiate new colonies. Rhizobia do not grow well under acidic conditions. If the soil has a low pH, add lime.

Phosphate may also be a limiting factor for NFTs. Superphosphate or rock phosphate may be applied if signs of phosphate deficiency appear.

### **Agroforestry Systems - Pros and Cons**

The community forester should be familiar with the advantages and disadvantages of agroforestry systems and should help the community members and local farmers understand the important issues involved in project and system selection. Some of the advantages and disadvantages are as follows:

#### **Advantages**

- Reduction of pressure on natural forest and upland ecosystems
- Sustained, year-round production
- Soil improvement (both chemical and structural)
- Watershed improvement (stability, erosion control, water production)
- Crop diversity and reduced risk
- More efficient use of space (more levels used, instead of single crops at one level)
- Microclimate improvement
- Shelter/habitat for wildlife
- Economic advantages (greater income, less risk).

#### **Disadvantages**

- Trees viewed as permanent
- Fewer short-term returns
- Long-term returns from trees difficult to predict
- New systems often less readily adopted by farmers
- Crop yield may decrease if system is not well planned and maintained
- Requires education of farmers and help from extension agents
- Commitment of national and local governments is necessary
- Initial capital expenditure may be required.

These advantages and disadvantages should be understood by individuals or community groups who may be considering an agroforestry system. The community forester should provide explanations and support for those engaged in the decision-making process, but should not try to convince a community to take on a task if they have strong feelings against it. It could be that what technical people see as advantages, local farmers may perceive as problematic. For instance, the protection of a wildlife habitat may be seen as providing a haven for pests such as rodents. Year-round production may be an unwanted benefit if people enjoy a break from the rigors of farming, or take on outside work.

Resistance to agroforestry schemes may be due to a number of factors, including the lack of a tradition of tree planting, unconsciousness of the importance and productive potential of trees, and overall lack of support for tree-planting activities. Some of this resistance may be overcome through education and persistence, and by providing examples of the benefits to be gained. Search out individuals who are more likely to try new ideas and use them as examples for others to follow.

### **Agroforestry and Food Production**

Food is of primary importance to all people, but especially to subsistence farmers, who often find it difficult to produce a regular supply. This problem can be alleviated by intercropping various species of trees with local foods. For instance, NFTs intercropped with local foods and fruits have the ability to

increase crop yields and thus have a positive impact on a subsistence farmer's standard of living. Or, fruit trees intercropped with other food crops provide a diversified diet and income. Another system might integrate all of the above on hilly land with the objective of controlling soil erosion, increasing soil fertility, as well as producing edible products.

The following planting methods are designed for any tree species. Because of common problems such as soil erosion and lack of productivity in the tropics, agroforesters are recommending the incorporation of NFTs in most projects. Intercropping NFTs is the most proven strategy currently in practice for increasing total food crop production, controlling soil erosion of sloping land, and stippling fuelwood and timber products. NFTs can be intercropped by planting them along the perimeter of a plot, randomly within a plot, or in alternate rows or strips. Each planting method has its own set of requirements and advantages.

### *Border Planting*

For agricultural crops that require a lot of light, or are normally grown on flat areas, planting trees along the border of a plot is a suitable method for producing a variety of products (see Illus. 7-2). Any type of tree can be planted as long as the trees do not compete with the crops for light and nutrients. Allow at least a 5 m x 5 m area around fruit and hardwood trees. NFTs can be planted closer together and still survive. Less shade intolerant crops can be grown closer to the trees as long as the soil is periodically fertilized .

Illus. 7-2. Border planting

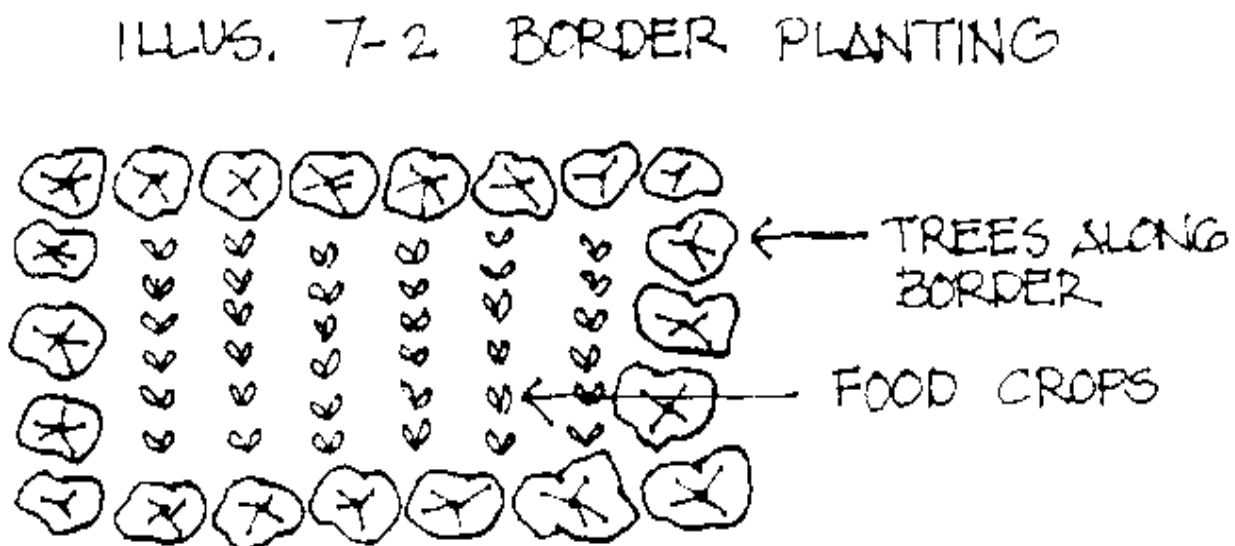

A method recommended to increase the fertility of the soil incorporates NFTs on the edge of the plot. The branches are periodically cut to any desired height above 1 m for use as green manure and are then spread around the planting area. Another method is to simply remove the leaves without destroying the branches. Removing branches is easier, but when only leaves are removed the branches remain intact, which ensures a more rapid regeneration of leaves.

Leaves can also be used as fodder, they can be collected and fed to livestock, or grazing can be allowed along the perimeter of the field. Plant trees close together to produce a live fence that provides fodder while keeping livestock out of the field.

### *Alternate Row Planting*

Alternate rows or strips (alley cropping) are preferred when on hilly farmland. A strip is formed by one or more rows of trees planted close together (see Illus. 7-3). Plant the rows along the contours to minimize soil loss. (See Appendix E for instructions on how to locate and mark the contours). Rows should be planted at the start of the rainy season to ensure germination. Many trees, such as Leucaena, can be directly sown with good results.

Illus. 7-3. Alternate row planning

### ILLUS. 7-3 ALTERNATE ROW PLANNING

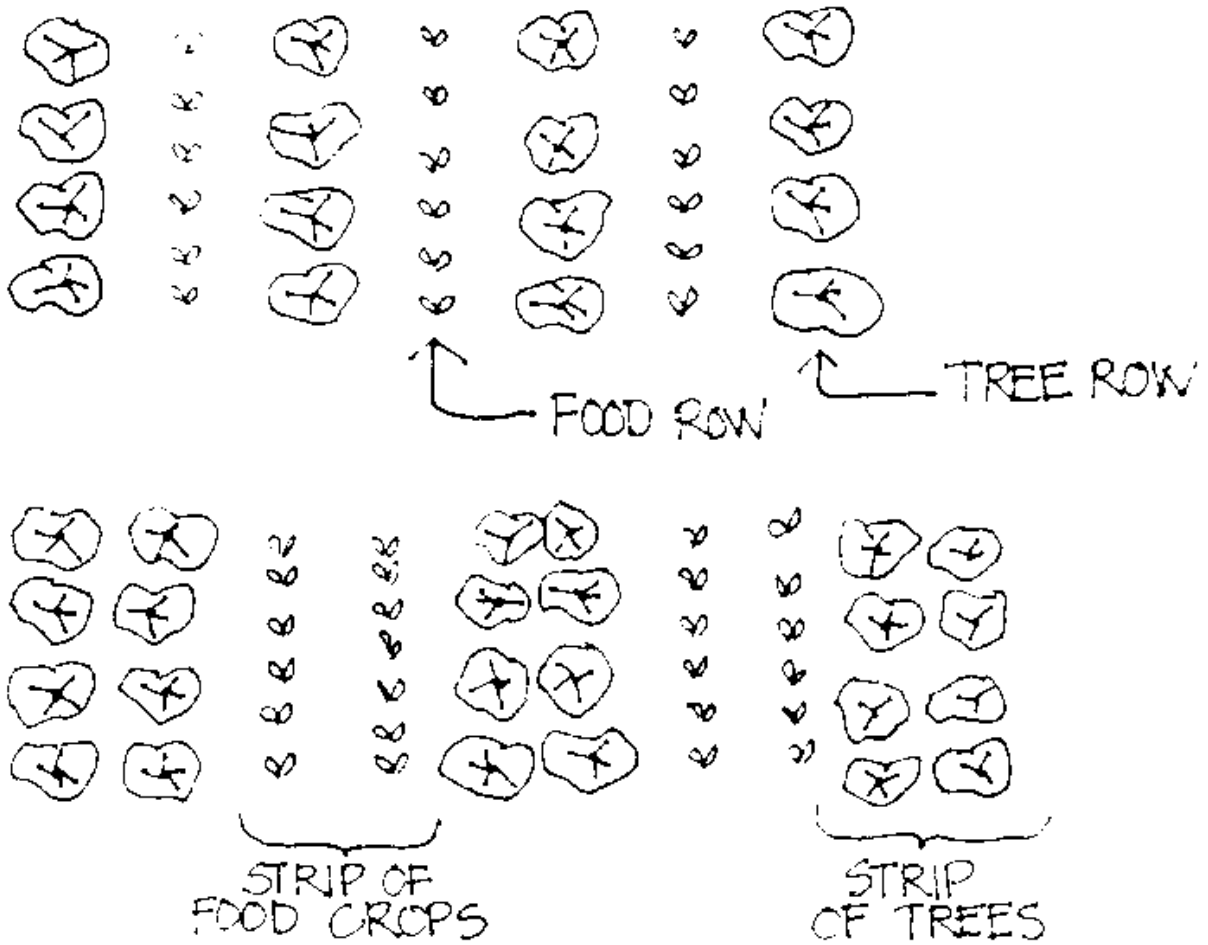

Trees with deep tap roots planted every 5 cm along the contour will intertwine, forming a fence of underground roots that hold soil very well. After two to three years a terrace will form above the row from eroding soil deposits and the build-up of organic matter (see Illus. 7-4).

Illus. 7-4. Alternate row planting on a slope

ILLUS. 7-4 ALTERNATE ROW PLANTING ON A SLOPE.

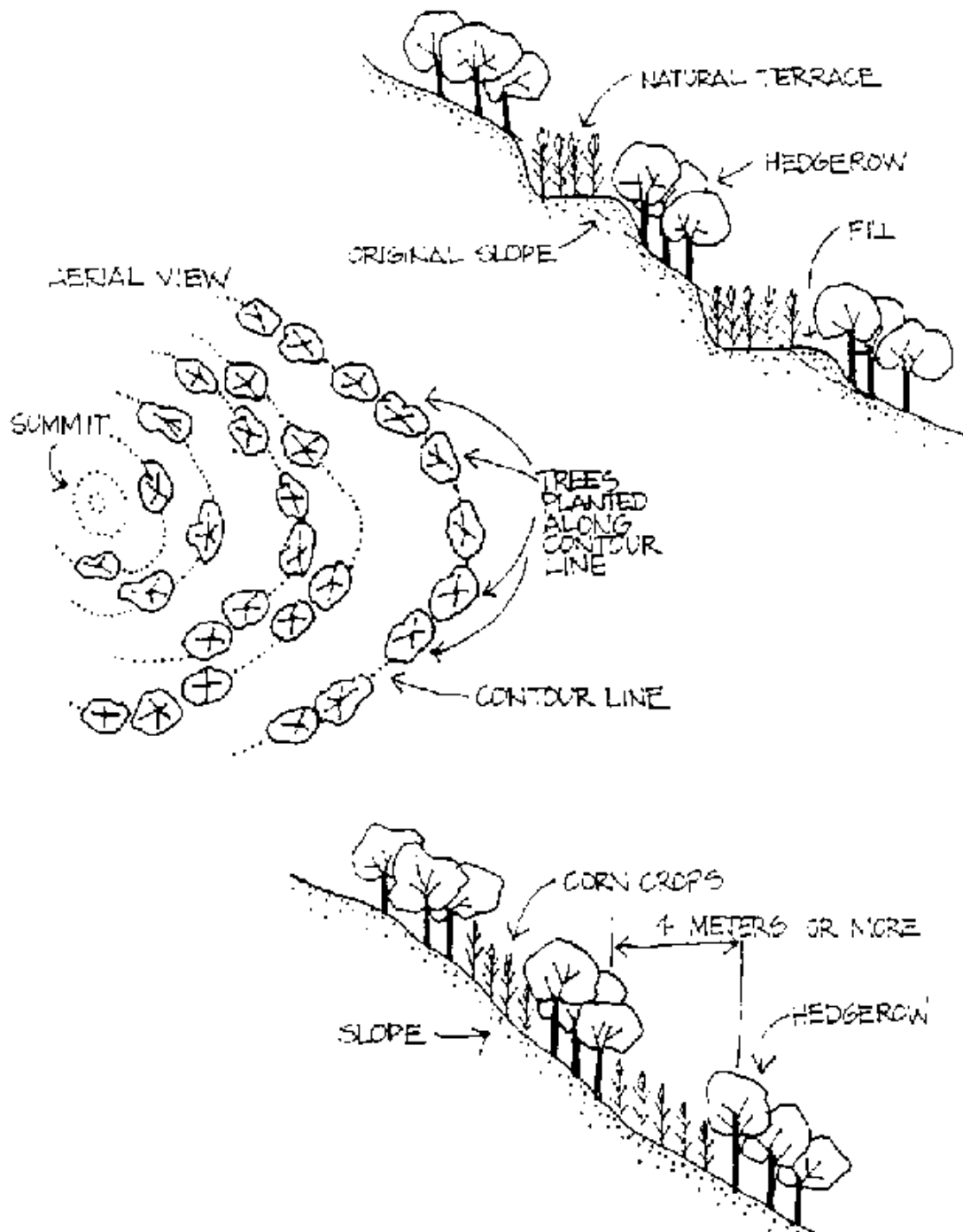

If planting *Leucaena* for the purpose of soil stabilization, not food production, plant the rows 1 m apart. For soil stabilization when crops are growing between the rows, plant double rows approximately four to five meters apart, depending on the slope and the light requirements of the crop. For gradual slopes, rows or strips can be 7-10 meters apart. This method is an inexpensive and easy means of erosion control. One advantage of alley cropping over border planting is that the proximity of the trees to the crops makes it unnecessary to haul leaves across the field to assure all plants have been treated. Rather, leaves are spread in the adjoining row of crops as they are cut from the trees.



The major products of the alley cropping and border planting systems are green manure and fodder. The close spacing of the NFTs prohibits the fast, high-volume growth needed for fuelwood and timber production. It also limits fruit and seed production (although it is possible to widen rows, as will be explained in the section on SALT). In both border and alley plantings, trees are pruned to collect the leaves for green manure and fodder and to reduce shading of food crops. It is important to prune at the correct time. If pruned too soon, the immature trees will die from inadequate leaf growth. If pruning is done too late, the food crop will be reduced because of shading by the trees.

The height of the tree stumps is also important. The higher the stump, the greater the leaf production, and regeneration (coppicing) ability of the tree. However, high stumps also reduce crop yields. A balance must be reached in order to optimize food production, leaf production and the coppicing rate of the trees. For convenience of cutting, a height of 90 to 100 cm is good. To determine if other heights are better under certain conditions, carry out trials for the species being used. Many farmers will be able to recognize changes in output of crops and leaves and can determine stump height for themselves. Seek out their advice for a better idea of the ideal stump height.

### *SALT*

SALT (Sloping Agricultural Land Technology) is an agroforestry system practiced on steeply sloping land prone to soil erosion and low crop productivity. Although the method is not new to extension agents and researchers, it has been successfully refined through practical hands-on application by a former Peace Corps Volunteer and a Baptist missionary working on the island of Mindanao in the Philippines (Watson, 1981).

The objective of SALT is to control soil erosion as well as produce one or several types of agroforestry products, such as fruit, corn, and/or vegetables. The method involves determining the location of the natural contours, preparing the soil, planting Leucaena, followed by one or several types of food or cash crops. Permanent crops such as citrus, cacao, and coffee are grown in between every fourth double row of Leucaena. The remaining rows are planted with non-permanent crops such as peanuts, beans, rice, and corn.

The first step in setting up a SALT system is to mark the contour lines on the slope (see Illus. 7-5). (See Appendix E for instructions on how to locate and mark the contours.) Plant a double row of Leucaena seeds or seedlings along each marked contour line. The spacing between each set of double rows of Leucaena depends on the steepness of slope and type of crop. An average spacing for steep slopes is four to six meters (see Illus. 7-6).

Illus. 7-5. Mark contour lines

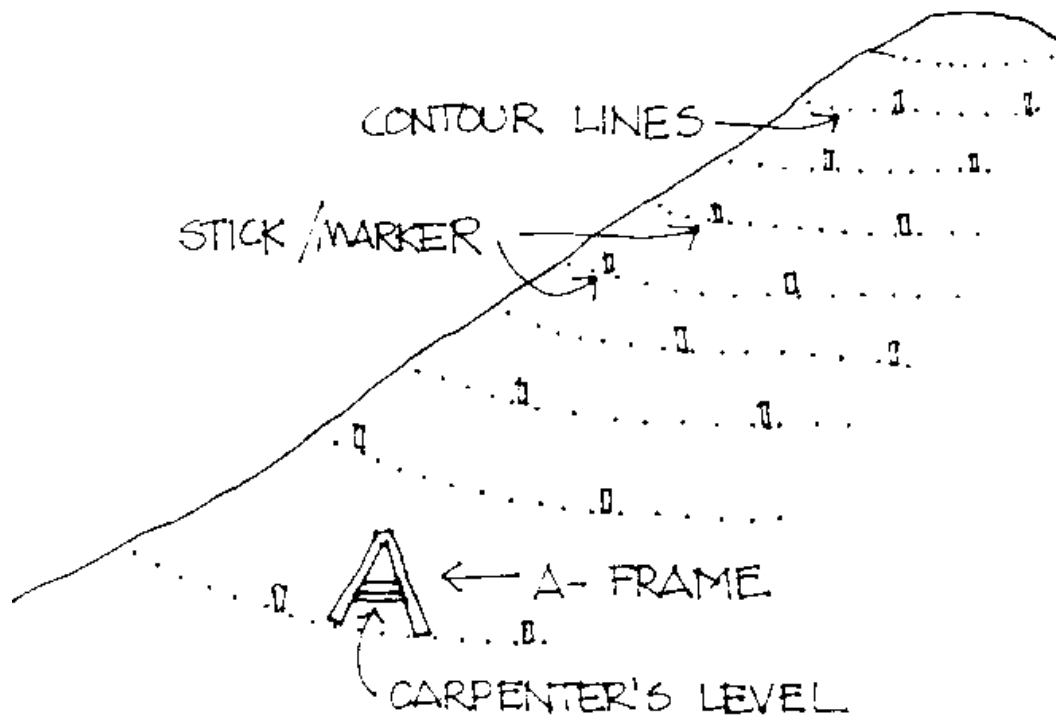

Illus. 7-6. Plant double rows of Leucaena

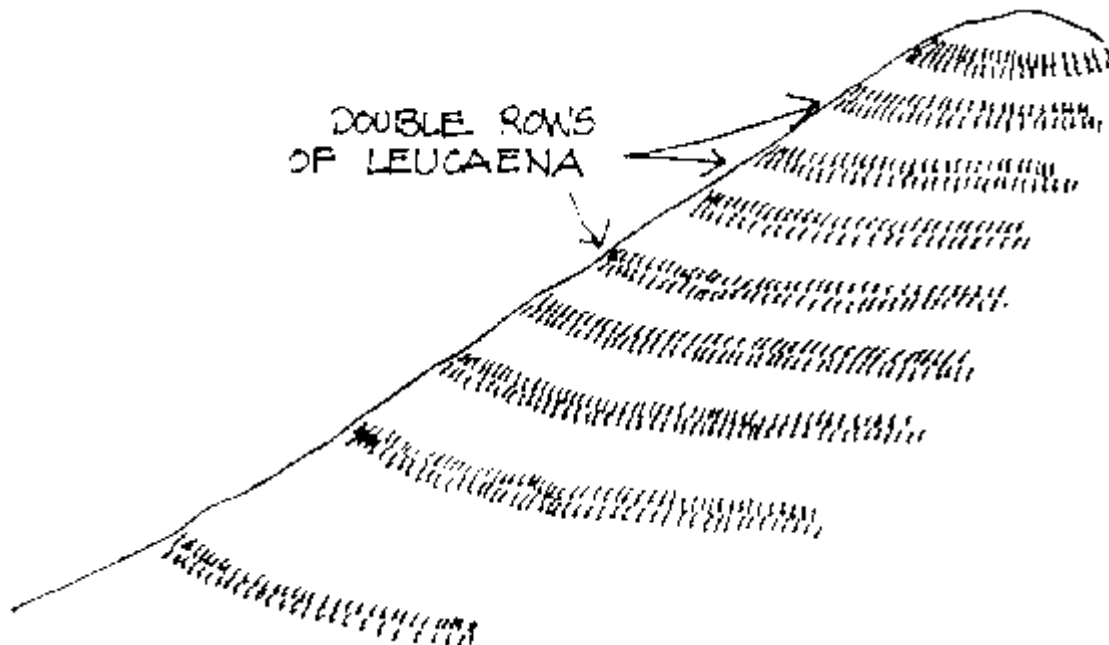

When the trees reach a height of several meters, cut them to one meter above the ground. Spread the cuttings at the base of the trees or in the area just behind them. As the trees mature they will begin to form a hedge. Over time, the area behind each contour will flatten out as eroding soil and rocks are caught by the trees and their roots.

If the soil on the slope is able to support crops, plant every fourth strip behind the hedge with a permanent crop (see Illus. 7-7). If the soil is completely lacking in nutrients, do not plant crops until the Leucaena has a chance to enrich the soil. The crops planted should be based on the nutritional needs and/or market demands.

**Illus. 7-7. Plant permanent crops**

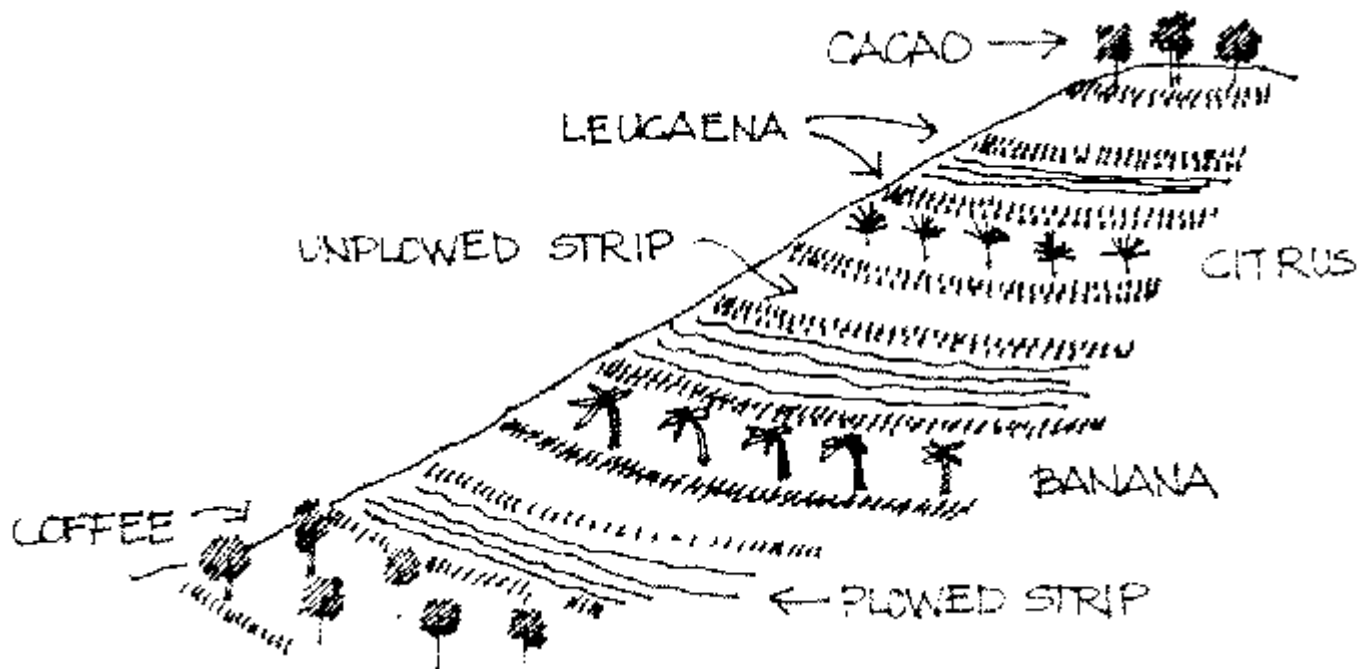

Following the establishment of permanent crops, plant the remaining rows to nonpermanent crops (see Illus. 7- 8). Always rotate the non-permanent crops in order to prevent the depletion of soil nutrients and the build-up of pests and diseases. After planting corn, rice, potato or pineapple, plant peanuts or beans. (For additional information on SALT contact Harold Watson, Mindanao Baptist Rural Life Center, Kinuskusan, Bansalan, Davao del Sur, Philippines.)

**Illus. 7-8. Plant non-permanent crops - A completed SALT project**

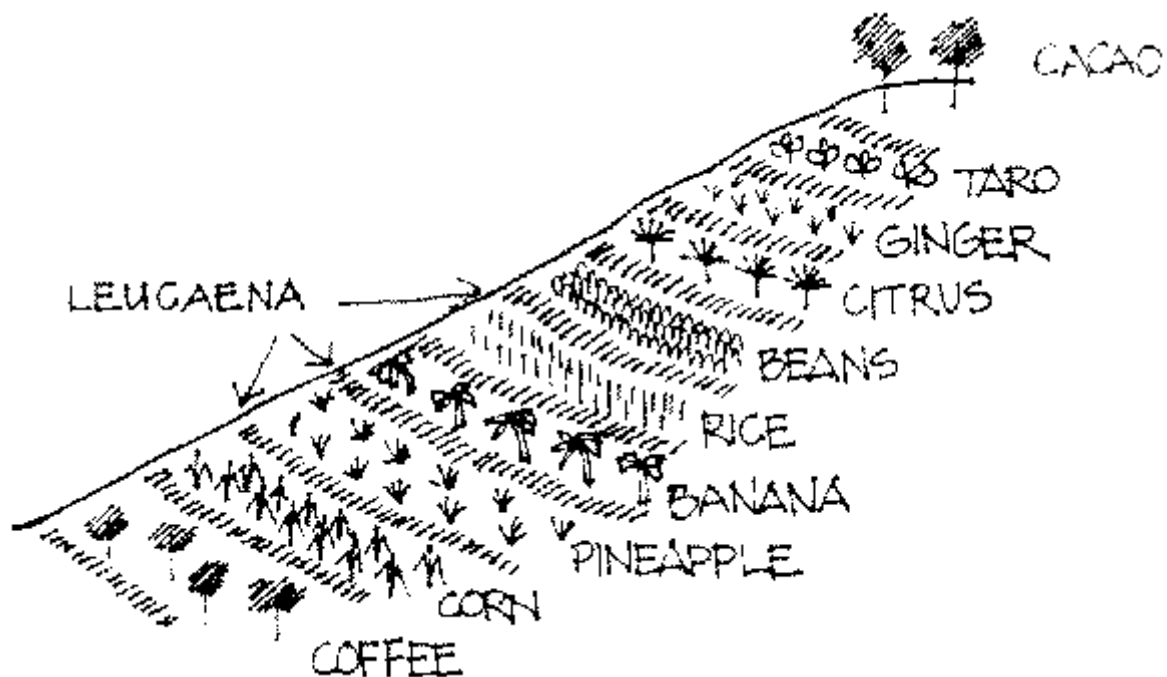

### *Home Agroforestry Systems*

The term **agroforestry** encompasses more than an agronomic system designed by foresters to achieve objectives such as erosion control, shading, fodder for animals, fruit, fuelwood, and timber. The evidence of a fruit tree providing shade for young tomato seedlings, a live fence of *Leucaena* supplying nutrients to vegetables, garden-grown greens fed to a fish culture, or cornstalks acting as support for climbing beans in a home garden implies the presence of an equally productive

agroforestry system. This suggests agroforestry is not limited to large-scale forestry projects, but is equally applicable to a household mixed garden. A botanist supporting this conception of agroforestry wrote about gardens in Central America:

By European standards the garden was disorderly, but productive; helter skelter in general aspect but intelligent in its basic patterns. It was simultaneously an orchard, a vegetable garden, a medicinal garden, a flower garden, a bee yard, a garbage disposal unit and a compost heap. It was in continuous performance, constantly in use, continually being planted... Every week in the year would find the garden in actual production. (Eckholm, n.d.)

Foresters and agronomists working in the tropics may want to understand the function and importance of home gardens in an agroforestry system. The concept of a household mixed garden resembles the agroforestry practice of mixed cropping. A mix of cultivated and semi-cultivated plants, both perennial and semi-perennial, are planted in the vicinity of a villager's dwelling with the objective of assuring a sustained yield of household consumables and marketable products. Complementing the plants can be any of a variety of animals.

In many societies, a mixed garden supplies food year-round. In some parts of the Philippines, gardens have been known to provide the sole source of food in the months preceding the rice harvest. Harvest from a properly planned mixed garden can supply animal feed, shade, organic fertilizers, medicinal plants, and building materials - much as an agroforestry project does, only on a smaller scale. Surplus products can augment income through sale to local markets. A variety of possible uses of home garden products and established cropping systems is explained below.

Medicinal plants are found in many tropical household gardens. In the less accessible areas of the tropical Pacific where modern medicine has been slower to reach, much of the traditional medical knowledge still exists. In the Philippines, tea brewed from the leaves of guava trees is used for stomach ailments. The juice from certain palms is used as an astringent for open wounds. Seemingly unimportant plants growing along a trail or deep in the jungle are highly valued for their healing powers. Many researchers claim that the cure for cancer may be an uncataloged plant growing in the tropical forest or cultivated in a home garden.

Certain trees thoughtfully planted around the perimeter of the house are a good source of material for garden fencing, animal shelters, firewood, outhouses, animal feed, home consumables, and outside markets.

Bamboo planted in unused areas makes excellent building material for chicken, rabbit, and goat shelters. When cut into strips and fashioned into a fence, it protects gardens against greedy chickens

Hardwood trees are good sources of material for tool handles, charcoal, and houses. If the household has the space and patience, valuable hardwoods can be cultivated and sold to lumber merchants.

Old or dead coffee and cacao trees can be cut down and used as firewood. Planted in the vicinity of the house, they provide consumables and a source of added income through the sale of the surplus. Village cooperatives can collect, process, and market the beans.

Jack fruit (*Artocarpus communis*), an expansive, densely foliated tree producing large fruit pods, is consumed by humans and animals. The seeds are edible and the flesh surrounding them is boiled and eaten as a vegetable by many households. Better yet, the uncooked flesh is a sweet, sticky candy and the favorite of many children. The remainder of the fruit may be fed to pigs

Nitrogen-fixing trees are invaluable in a household garden. The leaves and seeds from *Leucaena* provide food for goats and work animals, wood for firewood and fences, a non-caffeinated coffee, shade - and nitrogen for the soil.

Vegetables grown in the garden have a variety of uses. Leafy greens are a hardy source of iron for pigs. When chopped up the greens can be fed to fish. Cut grasses provide hay for work animals. Bran from corn and rice augments animal feeds. Taro is a good source of nutrients for people and animals. Above all, home gardens mixing beans, eggplants, greens, root crops, fruits, and tomatoes will supply all the necessary dietary nutrients required by a family.

Fish culture can also be an integral part of any household. Certain species of Tilapia, a hardy, fast-growing tropical fish, can be raised in small ponds. Little input is needed since the fish can live off of garden-grown foods such as chopped leafy vegetables, rice and corn bran, and copra meal. A more intensive system would include raising ducks in the fish pond. In this type of system, a duck house would be placed on the edge of the pond directly in the water. A fence, sunk in the pond and surrounding the house, would provide the ducks with access to water. This system would provide several benefits. The ducks supply meat and eggs, and their droppings fertilize the fish pond. Pig or goat pens similarly situated serve the same purpose. As fish and most animals prefer shady areas, fruit, leguminous, and hardwood trees can be planted along the edges of the pond.

Cheap energy is another product of a well-designed mixed garden. Installation of a bio-gas digester can convert animal manure and plant waste into a valuable fuel for cooking and fertilizer for the garden. The manure from three pigs, continuously composted in a digester, supplies adequate cooking gas for a family of three.

Integrating plants in a home cropping system may reduce input requirements. A system of intercropping can choke the growth of weeds by shading bare ground exposed to the sun, or by filling niches normally occupied by undesirable plants. The time saved in weeding frees household members for other endeavors. Plant diversity may reduce the chances of severe insect and disease problems, thus reducing the need for expensive inorganics.

Better use of nutrients, water and light through diversification may well increase garden productivity. The stratification of canopies improves use of incoming radiation. Similar below-ground diversity (variable rooting depths and abilities to capture beneficial elements) argue for more efficient nutrient retention. Litter-fall and the continuing partial harvests of these gardens tend to favor maintenance of soil-organic matter ratios. This can improve infiltration of moisture and recycling of nutrients.

Extension workers and researchers have designed numerous approaches to integrating the above systems into a productive home garden that uses local materials and planting stock and meets the needs and tastes of the household. Of course, examining existing practices is the best method of learning locally preferred plants, animals, and methods of production. More often than not, traditional systems have evolved from natural systems and therefore are suitable for the existing conditions. However, this does not preclude the introduction of less traditional agricultural species and improved production methods. (For additional information on home gardens see "Intensive Vegetable Gardening," available from ICE.)

**An optimal home agroforestry system** would integrate a variety of plants and animals (see Illus. 7-9). Often, due to technical, financial, land, or labor constraints, only one or two of the above elements will be used. In light of this fact, each element can be explained as an independent production system. Yet, with a little imagination and a lot of work, these elements can be combined into one home garden system.

### **Illus. 7-9. Home Agroforestry System**

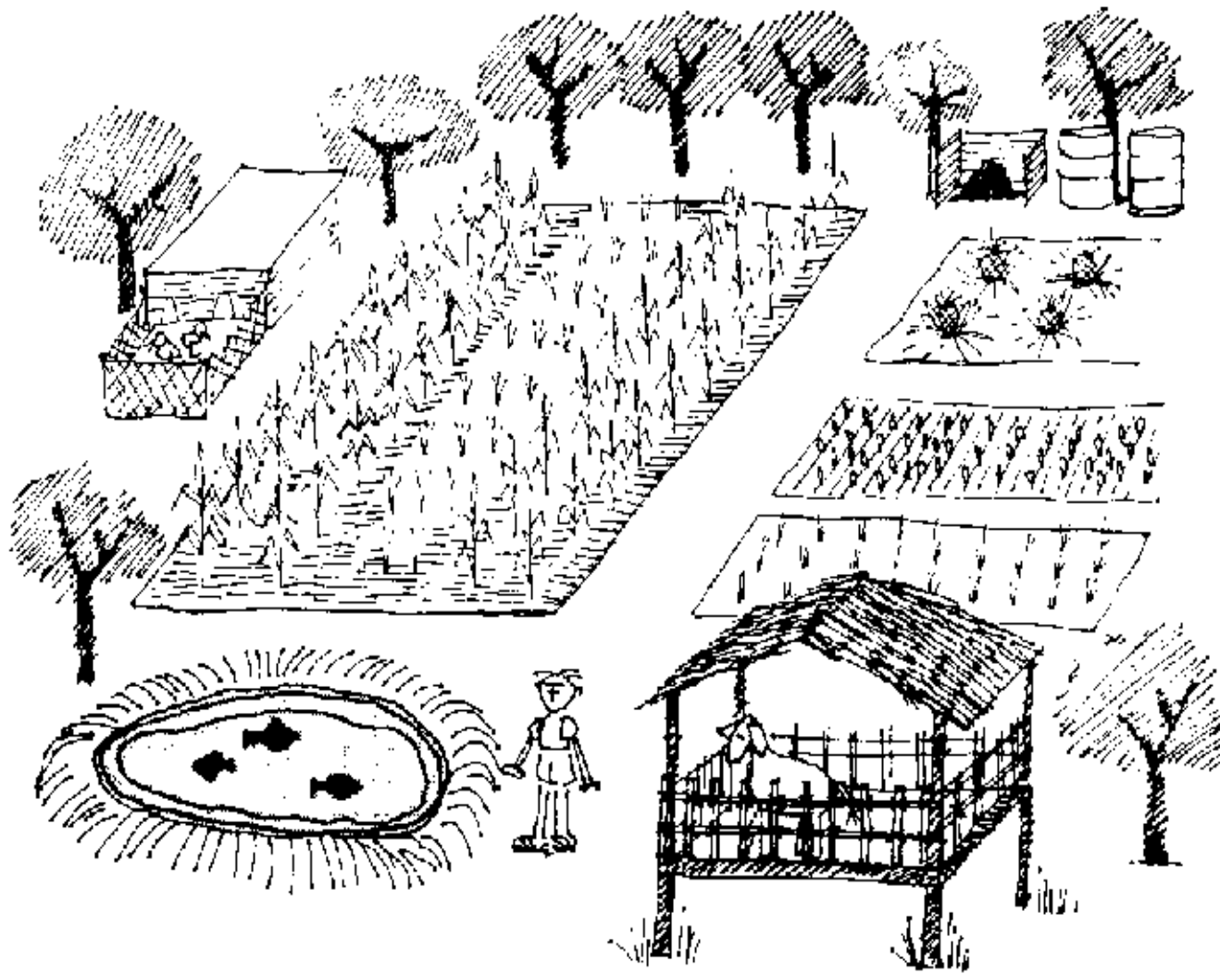

Illus. 7-9 Home Agroforestry System

**A home vegetable garden** should be nutritionally balanced to provide the proper plant proteins, vitamins, and minerals for a family of six. The size of the garden is 6 meters wide and 16 meters long (96 square meters) (See Illus. 7-10). Locate the garden in the most fertile area around the house. Pick an area which may have had a pig, chicken, or goat house on it. A place where the organic garbage was dumped is a good spot. If one area is all grasses, then natural fertility may still remain. Make sure there is plenty of sunshine. Many vegetables will not ripen without full light.

**Illus. 7-10. Home cropping system**

ILLUS. 7-10 HOME CROPPING SYSTEM

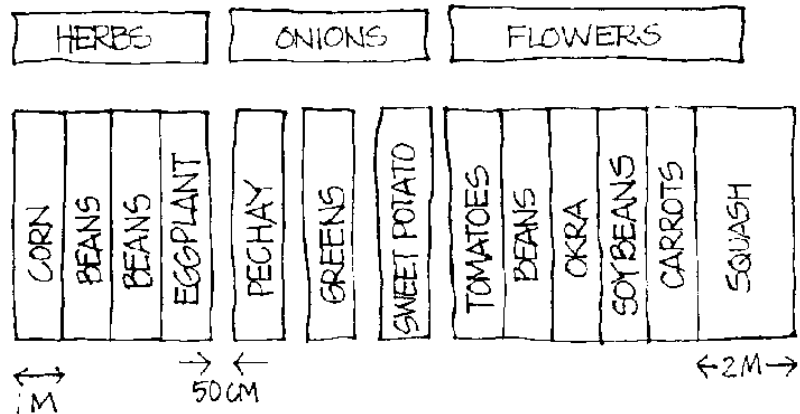

Find a well-drained area; continuous flooding will rot the roots. If possible, place the garden near a reliable supply of water. During dry periods it is critical to water the garden every day.

In order to supply food year round, plan on planting one-third of the area with crops that need to be replanted once a year. Examples are lima beans and the vegetable varieties of root crops. Plant another third with plants that need to be planted once every six months, such as eggplant. The remaining third can be planted with seasonal vegetables. Plant fruit trees around the perimeter, being careful not to overshadow the other plants (see Illus. 7-9).

To construct the garden, first mark off 96 square meters and each sub-plot within the overall area. The plots can be prepared two different ways. One method, known as **raised bed**, involves mounding the planting bed six inches off the ground. The soil is dug up, pulverized, and mounded into hills over the length of the bed. The sides are gradually sloped to control erosion. The top part of the bed is concave (see Illus. 7-11). This aids in the retention of water. In the second method, the plot is constructed at **ground level**. The soil is dug down six inches, then pulverized. (For additional information on the two methods, see "Intensive Vegetable Gardening," available from ICE.)

Illus. 7-11. Preparing the bed

ILLUS. 7-11 PREPARING THE BED

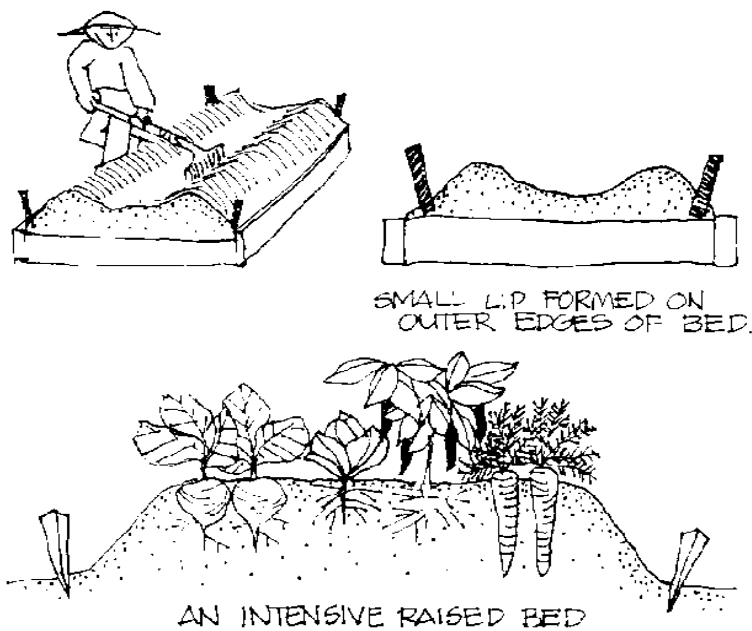

Regardless of the method, work the soil well, discard large stones, and incorporate organic additives. Remember, organic fertilizers break down quickly in tropical environments, and thus must be continually added. If the soil has a high percentage of dense clays, add fine sands. The sand will improve root penetration and water-retention capacity.

When the beds are prepared, plant the year-round vegetables in separate beds one meter wide by six meters long, with a distance of 50 cm between beds. Set the plants 20 cm apart. Apply one small can of 14-14-14 or 12-24-12 fertilizer per bed, if available.

Shorter-term plants such as beans should be planted in rows that are a meter apart. Separate each hill by 50 cm. Plant two to three seeds per hill. Fertilize each hill with one tablespoon of 14-14-14 or 12-24-12 before planting. Side-dress with the same amount every three or four months.

Plant the seasonal or four-month varieties in beds one meter wide. The distance between hills should be written on the seed package. If not, consult a government extension agent.

At the end of each planting, replace the crop with a variety that complements the previous crop. For instance, a crop that requires a lot of nutrients (corn) should be replaced by a crop that replaces nutrients (beans). Determine what combination of crops deters insect and disease infestation. Choosing the right combination of crops will reduce financial and labor inputs.

A practical method of supplying nutrients to a garden without purchasing inorganic fertilizer is to construct a **basket compost** (see Illus. 7-12). Basket composting is a process in which home garbage, garden and farm wastes, and nitrogen-rich plants are allowed to rot in baskets that are half-buried in a garden plot. The purpose is to provide plant nutrients directly to garden crops.

Illus. 7-12. Basket composting

## ILLUS 7-12 BASKET COMPOSTING

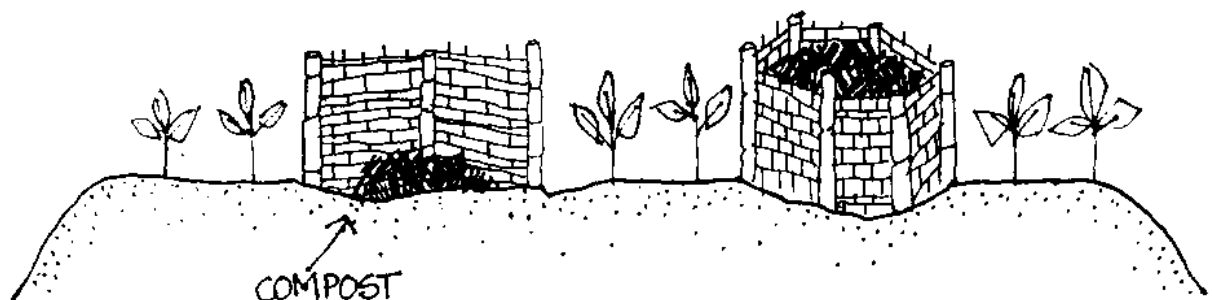

The materials needed to construct a basket compost are old round baskets at least one foot in diameter and one foot deep, or several stakes, and organic wastes. The purpose of the basket or stakes is to hold the organic material in place.

Prepare your bed as suggested above. Save all the weeds for use as composting material. Make holes in your beds at least one meter apart, six to eight inches deep, and wide enough to accommodate your baskets. If you are using stakes, place them an inch apart around the perimeter of the hole. If you are using bamboo stakes, it is possible to weave discarded strips through the vertical stakes to make a basket. Place the basket in the hole with six inches protruding above ground level. The most decomposed waste goes in the bottom of the basket. The new material goes on top. By the time the older material has totally decomposed, the newer material will be releasing nutrients.

Plant the seeds or seedlings two to three inches from the baskets. As needed, water the middle of the basket instead of the base of the plants. This way, the roots of the plants gravitate toward the middle of the basket and get the full benefit of the compost. There is no need to turn the compost because sufficient air and water are available for natural breakdown of the material. Just continue to add fresh organics to the top of the pile. Following harvest, remove the contents of the basket and spread them around its outer perimeter. Begin a new batch in the basket.

The advantages to basket composting are many. For one, it reduces the need to purchase expensive inorganic fertilizer. Two, it makes valuable use of discarded waste. Three, watering the center of the



basket rather than the entire plot reduces water needs. Four, it allows for intensive cultivation with minimal financial input.

**Citrus trees** can be valuable part of any home garden. They supply vitamin C and can provide an additional source of income for the household. There are many varieties of citrus to choose from, but choose ones that have good market value and are well liked by the family.

Citrus can be propagated from seeds and marcots, but budding is the preferred method. The method chosen will determine the date of transplant. Prepare the planting site by digging a square hole. Fill the bottom of the hole with compost. Transplant the seedling at the beginning of the rainy season. Seedlings should be at least one foot apart.

**NFTs** are also useful in the home system. Leucaena can be used for making posts or as lumber, firewood, and/or charcoal. Its leaves can be fed to farm animals. The leaves are also a good source of cheap fertilizer. When dry they contain 4.3% nitrogen, 2% phosphorus, and 1.5% potash. They are an excellent additive to a basket compost. The seeds can also be dried, roasted, and ground into a coffee-like beverage. (Information on propagating, maintaining and harvesting Leucaena is in Chapters 4 and 5 and Appendix C).

**Animals** can also play a positive role in a home agroforestry project. They can feed from vegetables and trees grown around the house. Although it is difficult to grow all the nutrients required by animals, it is not impossible. Harvested trees can be a source of construction materials for animal shelters.

**Goats** are known to eat Leucaena, as well as many types of wild grasses found on the islands of the tropical Pacific. A household may grow these grasses or collect them from nearby fields. If a pasture is available, allow the goats to graze freely for eight hours a day. If a pasture is not available, feed them concentrates consisting of rice or corn bran (78 kg), molasses (10 kg), copra meal (10 kg), and salt (2 kg) every day. Fresh grasses and Leucaena should be provided in the goat pen. Clean out the remaining grasses at the end of each day: goats will not eat old food. Provide fresh, clean water at all times.

Shelters for goats are easily constructed out of local materials. Bamboo cut into strips makes good flooring and siding, and it can even be used as a roofing material. A mature piece cut in half is adequate for a water or feed trough. (For additional information on raising goats, see "Aids to Goatkeeping," or "Homesteader's Handbook to Raising Small Livestock," available from I CE).

**Pigs** are also a common sight in many villages in the tropical Pacific. They are an important source of food and income, and require few inputs. The most common pig is a native black variety that runs freely or is tethered to a tree. Pigs subsist on human discards, root crops grown in gardens, and wild plant material. However, in some cultures, pigs are subject to religious taboo.

In the last decade, hybrid pigs have become as popular as the native variety. Hybrid breeds, such as Landrace, Duroc, and Hampshire, grow faster and bigger than the native variety and thus are a prize for any household. However, many of these newly introduced varieties are considered less suitable in a village situation because of special dietary and shelter requirements. Minor adaptations of village-level technology can be undertaken to meet these requirements.

Hybrid pigs require shelter from the elements. Place the house on slightly sloping ground so that runoff does not pool on the floor. For a permanent house, use a concrete floor, which makes cleaning easier and helps minimize the presence of pests and disease. A 3m \_ 3m pen can accommodate one sow and her young, 10 to 12 growing pigs, or six to eight fattening pigs. Make the walls one meter high for convenience of cleaning and to keep the pigs from escaping. A feed and water trough can be made of concrete; other materials are also suitable.

Pigs have a voracious appetite and will eat almost any kind of food. Common feeding methods utilize cooked vegetables from the household garden. More modern methods use nutritionally balanced concentrates. At the village level it is recommended to feed hybrid pigs a combination of the two. Mix garden-grown vegetables, especially greens and the chaff from ground corn or rice. The combination of the two will provide iron, proteins, and carbohydrates. Periodically supplement the diet with store-bought feed. The success of the feeding will be evident by the growth of the pig, so weigh the pig periodically and adjust the diet accordingly. Most important, maintain the good health of the pig by observing sanitation procedures and immunizing against hog cholera and swine plague. (For

additional information on raising pigs see, "Small-Scale Pig Raising," and "Swine Science", available from ICE.)

**Fish farming** is becoming popular in the tropical Pacific, especially in upland communities that lack access to fresh fish because of distance and transportation problems. Fish farming is a simple method of producing food high in essential nutrients, as well as increasing income through sale of the surplus.

**Tilapia** has responded most favorably to backyard and large-scale culture. It has proven to be fun, profitable, and beneficial to many small producers. The fish grows fast; it only takes three to four months for a Tilapia fingerling to weigh approximately 150 grams, an edible size. The fish reproduces quickly, maturing at four months and reproducing every two to three months. A pair of mature Tilapia can reproduce 4,000 to 6,000 offspring in one year. Tilapia can live in rice paddies, irrigation canals, ditches, rivers, lakes, swamps, reservoirs, fish tanks, and backyard ponds. It is easy to feed them, and they will eat any kind of feed provided. They will also eat insects and blue-green algae. Tilapia is tasty when fresh, and equally palatable when dried.

There are three types of Tilapia to choose from. The most common variety is Java or Mossambica. The Java and Mossambica males are blackish in color; the females are whitish. The other variety is Nilotica. It is lighter in color, with silky stripes on its dorsal fins and tail.

Although it is possible to raise the Tilapia in one pond, it is best to raise them in three separate ponds. One pond is for the breeding Tilapia, the second pond is for the young or fingerlings, and the third is for the growing Tilapia. Place the ponds where water is accessible throughout the year. The pond should be well exposed to sunlight. This exposure will hasten the growth of edible algae in the pond. If space is limited, several fruit trees planted on the north side of the pond will not adversely affect algae proliferation.

The size of the pond is determined by the number of fish you plan to raise. A good guide to allow is two to three mature fish per square meter of water surface. The depth of the pond should be one meter. Be aware that the hot sun will evaporate pond water quickly. Refill the pond accordingly.

Screen all water inlets and outlets to avoid the escape of Tilapia and to prevent the entrance of predatory species. Keep the pond free of lilies and similar plants. They will compete with the fish for space, air, sunlight, and nutrients.

Fertilize the pond once a week or until the pond is greenish. Use commercial fertilizer or organics such as compost, fresh manure, and leaves from Leucaena. Apply 1/2 kilo of urea and 1/2 kilo of 15-15-15 on a monthly basis. Supplemental feeds can include rice bran, corn bran, copra meal, and leaves from Leucaena. You can train the fish by clapping your hands at feeding time. Over time the fish will respond to the clapping and swim to the feeder.

For every 10 female breeders, provide two to three male breeders. It takes practice to distinguish the two. Transfer the fingerlings from the breeding pond to the nursery pond when they are the size of a small coin. Transfer only the males from the nursery pond to the growing pond when they are about the size of two fingers. Do not mix the males and females in the growing pond. The females grow more slowly, thus making it more difficult to determine the proper harvest time. Either eat the females or place them in a separate pond. After two months, or when the Tilapia weigh 150 grams, harvest them from the growing pond using a net.

When stocking the pond, make sure there are no predatory fish. Stock in the early morning or late afternoon in order to control trauma. (There are several sources of information on fish culture available from ICE: "Tilapia: A Guide to Their Biology and Culture In Africa," "Integrated Agriculture Aquaculture Farming Systems," "The Biology and Culture of Tilapias: Proceedings of the International Conference on the Biology and Culture of Tilapias.")

Integrating **ducks** in a fish pond is an excellent way to conserve space, supply nutrients to the pond, provide meat and eggs to the household, and earn extra income. Place a duck shelter at the edge of the pond, directly in the water. The shelter can be constructed out of local materials. A roof is necessary to keep the ducks dry (ducks get sick easily when wet from rain). Slot the floors so the droppings fall directly in the water. There should be three to four square feet of floor space per duck. Sink a wire or wood fence surrounding the shelter in the pond. Leave enough room so the ducks are

not crowded when in the water. A wood or bamboo ladder will supply the ducks access from the shelter to the pond.

Most varieties of ducks start laying eggs when they are four to six months old. Other varieties start laying at six to seven months. For breeding one male duck is needed for every five female ducks.

Ducks can be fed commercial as well as home-grown feeds. A home-grown mixture should include rice bran (55 kg), ground corn (20 kg), shrimp or snails (25 kg), wood ash or ground charcoal (1.5 kg), table salt (250 g), and ground limestone (250 g). The ducks should also have a plentiful supply of chopped greens. Ten grams a day per duck should be sufficient. Provide fresh drinking water all the time. If the objective of the plan is egg production, harvest the ducks as their egg-laying productivity declines. Otherwise harvest the ducks at six months, when they are at full weight.

### **Agroforestry and Livestock Production**

Livestock are important sources of food for people throughout the world. They provide high-quality meat protein and by-products such as milk products and hides. Animals also serve as a way to store value from food crops, either through the sale of the animal for cash or by the slaughter of the animal at maturity.

Animals have nutrient needs just as humans do, and they are healthier when those needs are met. Healthy animals grow faster and resist infection and disease better than sick animals. The leaves and fruits of certain tree species are consumed by animals. NFTs can add needed nutrients, especially proteins, to the diet of livestock. Nitrogen is a key ingredient of amino acids, which are the building blocks of proteins. Amino acids are found in high concentrations in the leaves of NFTs. These leaves, when palatable, can meet most if not all of the protein needs of livestock when used as fodder.

Two agroforestry systems exist which can be used to increase livestock growth and health: growing fodder trees and planting grasses and other feed plants between trees.

**Growing for fodder** is a relatively simple system similar to growing trees for food. The major difference is that trees are continually pruned to provide a sustainable food source. Animals feed directly from the trees or the branches and/or leaves are brought to them. Trees are spaced to allow good development and to prevent crowding. Pruning schedule and height of cut are set up to maximize fodder output and to allow the animals to reach the leaves. In hot climates, 10-15 trees/ha are left unpruned for shade. Good fodder trees include Gliricidia, Sesbania, Calliandra, and Leucaena, although Leucaena, if overconsumed, has been reported to cause hair loss in cattle due to a mimosine in the leaves.

There are various methods for cultivating trees solely for fodder. One method is to collect fodder from NFTs grown in alley cropping systems when a surplus of leaves is available. This method requires cutting the branches and bringing them to the livestock. On the other hand, livestock may be allowed to roam freely in an alley cropping field after the annual crop has been harvested. This system eliminates the need to collect and move fodder. Another advantage to this system is that more food is available, since livestock can also feed on crop residues after the harvest. Yet another advantage is that animal manure, a valuable soil additive, is applied directly to the field with this method. Some farmers practicing SALT also allow their work animals to feed on Leucaena hedges on the slopes.

Disadvantages to growing trees solely for fodder include the following:

- Unavailability of trees for other uses, such as fuelwood and timber, due to frequent pruning;
- Trees allowed to grow to the optimum height for inhibits annual crop growth; and
- When livestock feed directly from the tree, annual crop growth is impossible.

When livestock are allowed to feed on NFTs in fields where intercropping occurs, disadvantages include trampling and compacting of the soil and reduced amounts of green manure available to annual crops.

Plants favored by livestock can be **intercropped between rows of trees** planted for fuelwood, timber, pulp, or other tree products. Two types of integrated livestock-food production systems are silvo-pastoral and agro-silvo-pastoral. Both are rotational systems, in which crops and/or livestock are introduced at specific times in the rotation of the tree crop.

In a **silvo-pastoral system**, livestock and their food plants are introduced in the middle of the rotation. It is necessary to wait for the trees to mature sufficiently lest they be eaten or trampled by livestock before grasses or other feed crops are planted between them. Livestock are placed in the area when the grass is ready for grazing. The cultivated trees do not have to be NFTs or food sources for the livestock. However, secondary products, such as seeds which fall to the ground and are eaten by livestock, can increase the animals' weight gain. Livestock may increase tree yields by adding manure to the soil, but on the other hand they may decrease tree yields by damaging trees and compacting soil.

An **agro-silvo-pastoral system** is nearly identical to silvo-pastoral system, except that nonpermanent crops are grown between the seedlings at the beginning rather than at the middle of the rotation. Regular weeding reduces competition and increases the seedlings' chances of survival. When the trees are mature enough, grasses and other feed plants are grown and livestock introduced as in a silvo-pastoral system.

The advantage to both systems is the increase in overall productivity of the land. This benefit must be balanced against the possibility of lower tree yields, or longer rotation times. The entire system must be evaluated using economic as well as ecological criteria. The community forester should help local farmers make informed choices about which type of system to implement.

### **Agroforestry for Fuelwood Production**

Fuel is second only to food in importance to subsistence farmers. Traditionally, fuelwood has been the major source of fuel in most parts of the developing world. For many people, fuelwood may be the only reliable form of energy for cooking, heating, and light. Until recent years it has been the most readily available form of energy for subsistence farmers.

In the past fuelwood was collected from natural forests and usually consisted of fallen branches, brush, and dead limbs. Only rarely were trees cut for use as fuel. Population pressures were minimal and forest areas were large enough to provide adequate fuelwood to most communities. Changes in population and land-use patterns have altered this situation, and fuelwood is scarce in many areas. The need for substitute fuels has become acute. In areas where the fuelwood supply has been seriously depleted, substitutes include animal dung and crop residues. However, when these materials are used for fuel, their benefits as fertilizers and soil conditioners are then lost. When dung is dried and used as fuel, organic nitrogen which would have been beneficial to plant growth is lost. (For information on alternative sources of fuel, see "Food, Fuel, and Fertilizer from Organic Wastes," "A Chinese Biogas Manual," and "Methane Digesters for Fuel, Gas, and Fertilizer," available from ICE.)

Agroforestry systems can be designed to produce adequate fuelwood on individual or community plots while still allowing for food production. These systems can reduce the pressure on natural forests and the time it takes for villagers to find and collect fuel.

The most important criterion for selecting fuelwood species for domestic use is their potential to ensure a continual fuelwood supply. Other considerations include coppicing ability, amount of smoke produced when burned, and structure of the wood (dense woods provide greater heat when burned).

Tree species selected for agroforestry fuelwood systems should fit all the criteria for trees outlined above and in Chapter 5. (For additional species see Appendix C). To produce the greatest amount of heat energy, trees with high heat content **per volume of wood** produced should be selected. It should be noted that the heat content of wood per kilogram is the same for most tree species. Choosing a tree with a high heat content per volume produced is done to ensure the greatest heat value for the growth recorded. The heat value of a type of wood is determined as follows:

1. Measure and cut a stack of wood so that all of its dimensions are one meter. This is a cubic meter of wood.
2. Weigh the cubic meter of the wood to give kg/cubic meters, or density.

3. Laboratory tests have determined that most woods contain about 21,000 kilojoules ((kj)/kg. To determine the heat content of a tree species, multiply the density (kg/cubic meter) by 21,000 kj to get kj/cubic meters, the heat content of the wood.

A sample determination would be as follows:

A tree is cut down and the trunk is cut into one-meter lengths. The lengths are stacked one meter high and one meter wide, making a cubic meter of wood. All of the lengths in the stack are weighed. The total weight comes to 300 kg. The density of the wood is 300 kg/cubic meter. The heat content of the wood is: 300 kg/cubic meter X 21,000 kj/kg = 6,300,000 kj/cubic meter

Heat contents for different tree species can be determined and compared. Given a choice between species with similar characteristics, the species with the higher heat content should be chosen as a fuelwood tree. (For the heat content of selected fuelwood species, see Appendix C).

Spacing considerations of trees planted for fuelwood production are similar to the spacing of trees planted for food production. Intercropping and fodder production is limited, as trees will be closely spaced, and pruning is infrequent. However, crops can be planted in between rows when plants are still young, and branches that are pruned can be used as a fodder supplement. If NFTs are used, fallen leaves can be collected for green manure and fodder.

Develop a system that provides fuelwood on a sustainable basis. NFTs with short rotations (3 years) are planted at different times so that maturation is sequential. Using this method, a farmer can plant three stands or strips of NFTs at different intervals and harvest fuelwood continuously. The procedure is as follows:

1. Determine the fuelwood needs of the project. This is difficult to do and may require a best-guess estimation. For this example, assume that one family uses 10 cubic meters/year.
2. Determine the yield of the trees planted. A reasonable yield for Leucaena spaced 0.5 m \_ 1 m is 100 cubic meters/ha over the three year rotation.
3. Plant enough trees to produce 10 cubic meters/year. If a hectare produces 100 cubic meters over three-years, then 0.1 ha will produce 10 cubic meters over three-years. One five-row tree strip 4 m wide and 250 m long will produce 10 cubic meters of wood over three years. An equivalent area can be used for the same yield.
4. To produce fuelwood continuously, three rows 4 m wide and 250 m long (which will mature at different times) are needed. Plant one row the first year, the second row the next year, and the final row the third year. Harvest the first row in the third year. If the tree coppices, let the first row regenerate itself. Otherwise replant the row. Continue the cycle for all of the rows. The schedule for planting and harvesting using this system is summarized as follows:

YEAR	PLANT	HARVEST
1	row 1	
2	2	
3	3	row 1
4	1	2
5	2	3
6	3	1
etc.	etc.	etc.

After three years, this system will provide continuous fuelwood for one family. If the quantity produced is too large, the farmer can reduce the amount of land being used for fuelwood or sell the surplus if a market exists. If the quantity is insufficient, the farmer can increase the amount of land dedicated to fuelwood production, if possible. The farmer must decide on the best allocation of land with the help of the community forester.

Planting fuelwood trees can be done by direct sowing or by transplanting nursery stock at the beginning of the rainy season. Transplanted trees will survive better than trees planted directly, and Rhizobia bacteria can also be more easily introduced. The cost of nursery production will be greater,

however. Each species and planting site will have different variables that will favor one or the other of the planting methods. Determine the best method after careful analysis.

Care of fuelwood trees and sites is necessary to ensure a continuous yield. Reseed or replace any dead trees. Cut trunks at an angle to prevent rainwater from collecting and rotting stumps. This will reduce tree loss and increase coppicing rates. Coppicing rates can also be increased by cutting high on the stem, although this reduces the amount of wood harvested. Let farmers determine the best height for maximizing coppicing and productivity. If many stems emerge from a tree after cutting, cut away all but the strongest. This will reduce competition between stems and increase fuelwood output.

### **Agroforestry for Timber Production**

Timber is needed by small farmers and communities for construction, tools, and fencing. Local markets for pulpwood, poles, and sawn logs may also exist; if so, farmers may use wood sales to generate income. Small farmers can use a simple strategy to raise food crops while producing timber products for local use and sale. Intercropping timber or pulpwood species such as Albizia falcataria or NFTs with cereal and root crops is one such strategy.

Small farmers are generally interested in quick returns with little input. Select timber trees that can be harvested after four to ten years. Trees must grow straight and be relatively knot-free for ease of use in construction.

For intercropping crops with timber species, select trees with thin canopies. This will allow light to reach the crops for a longer period of time. Timber trees are generally spaced 4 m \_ 4 m. Due to this wide spacing, timber intercropping is inappropriate for erosion control. Different agroforestry strategies should be considered for sites or communities that require erosion control measures. The requirements of the species and planting site will determine whether seeds are sown directly or seedlings are transplanted from the nursery.

A simple schedule exists for intercropping timber or pulpwood trees with rotations of four to ten years (see Illus. 7-13). For the first two years grow crops that need a lot of light between the rows of trees. As the canopy closes, plant shade-tolerant crops such as sweet potato between the rows. After four to five years, thin the stand by removing every other row and selling what is harvested. Grow crops until the canopy closes; then plant shade tolerant crops. When the remaining trees are harvested, replant the stand; the cycle begins again. A summary of the cycle is shown in the table following illustration 7-13.

Illus. 7-13. Intercropping Timber and Food Crops

Illus. 7-13 Intercropping Timber and Food Crops

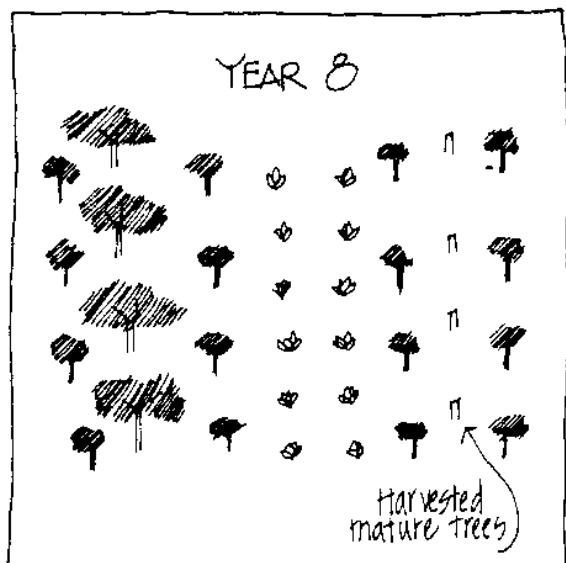
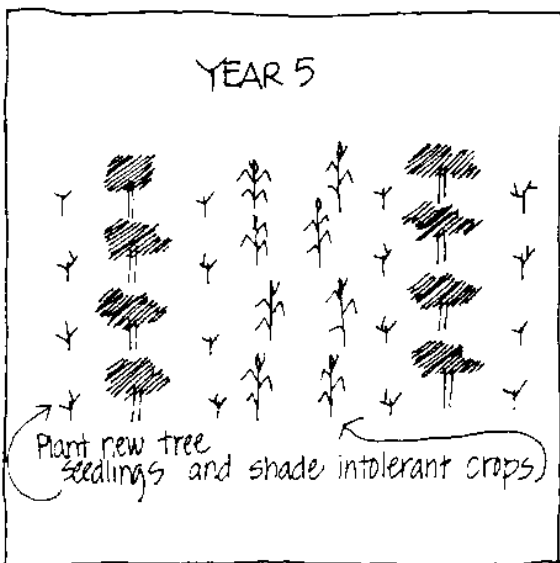
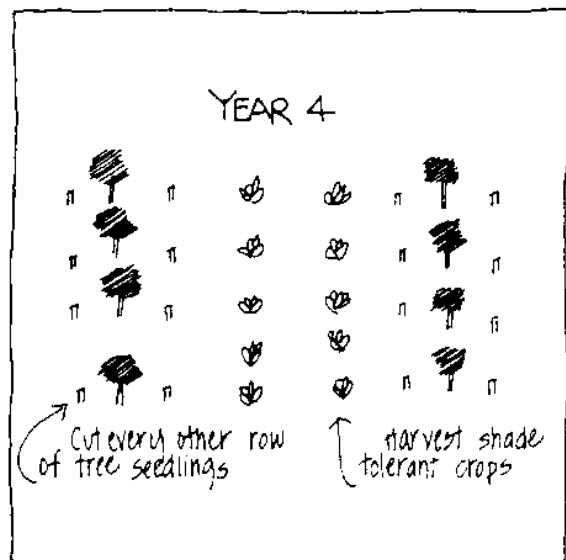
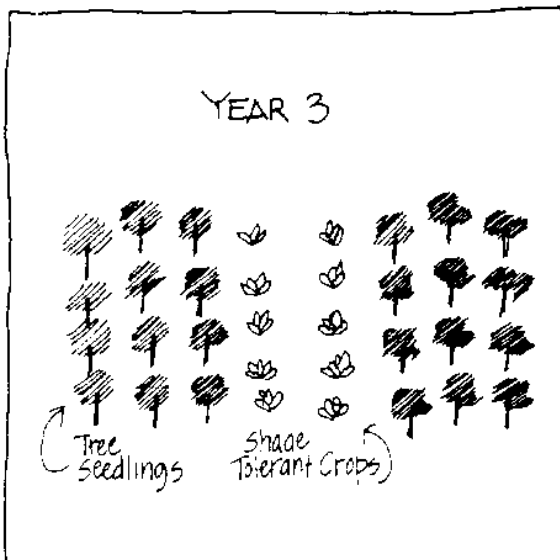
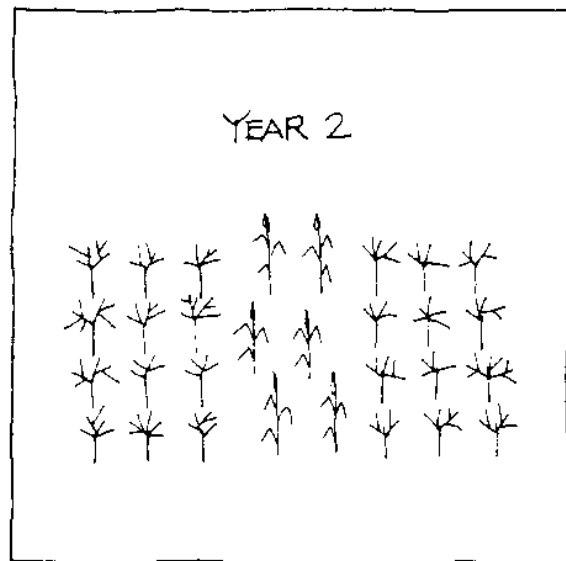
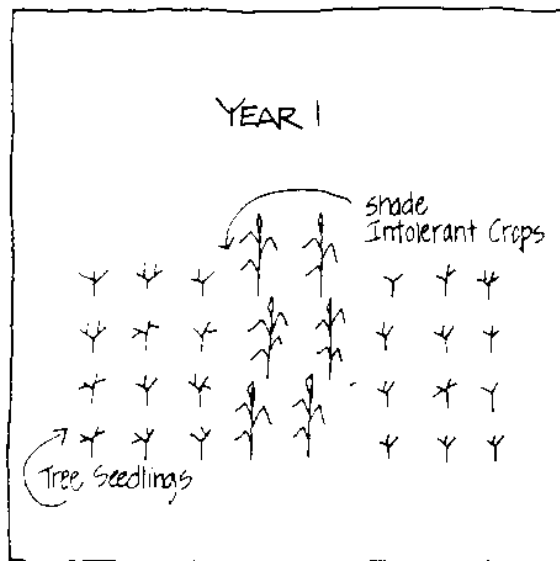

YEAR	FOOD CROP
1-2	Plant cereal, other crops that demand light.
3 - 4	Plant root, other shade -tolerant crops.
4-6	Plant cereal crops.
6- 8	Root crops,
1	Plant seeds or tree stock for timber, pulp.
4	Thin every other row and sell harvest. Use leaves of NFTs for green manure.
4*	Second tree crop can be planted if conditions permit (adequate light).

\* Care must be taken if the second planting is attempted this early in the cycle. Young trees could be damaged when final harvesting occurs, and they may not grow vigorously with the limited light and water available.

This system has been very successful for Albizia when it is planted to supply pulpwood to local paper mills. The proper schedule will depend on the species used and local conditions. This system can be developed to produce on a yearly basis, providing a steady income to farmers. Instead of devoting the entire plot to the same schedule, divide the plot into sections. The number of sections is determined by the age of rotation. If the age of rotation is 6 years, for instance, divide the plot into six sections and plant one section per year every year for 6 years. Replant each section after harvesting. After 6 years the farmer will have products to harvest (not including thinning products and crops planted between rows) every year.

The success of this system depends on the existence of a market for timber or pulpwood. If no such markets exist, timber may still be grown for private use, but it will be on a limited basis. Markets can be developed for wood products, but this requires a long time and success is not assured. If markets do not exist, consider other agroforestry strategies that will better serve the needs of the community and individual farmers.

### Bibliography

Adeyoju, S.K. 1980. "The Future of Tropical Agroforestry Systems." Commonwealth Forestry Review, 59(2): 151-161.

Agricultural Extension. 1983 ICE, Manual number M18.

Arnold, J.E.M. 1983 "Community Forestry and Meeting Fuelwood Needs." Commonwealth Forestry Review, 62(3): 183-189.

Arnold, J.E.M. 1983 "Economic Considerations in Agroforestry Projects "

Agroforestry Systems, 1:299-311

Audio-visual Communication Handbook ICE, Manual number M20.

Bamboo as a Building Material, 1953. ICE, Manual number R33.

Baver, L.D., Gardner, Walter H. and Gardner, Wilford R. 1972. Soil Physics. 4th ed. New York: John Wiley & Sons, Inc.

Bonvoisin, S. 1982. "Agathis: A Genus of Fast Growing Rain Forest Conifers." Commonwealth Forestry Review. 61(2): 145-150.

Budowski, G. 1980. "The Place of Agroforestry in Managing Tropical Forests." In Mergen, F., ed., 1980, Tropical Forest Utilization and Conservation: Proceedings of an International Symposium, April 15-16, Yale University, New Haven, Conn.

Burley, J. 1980. "Selection of Species for Fuelwood Plantations " Commonwealth Forestry Review, 59(2): 133-147

Casuarinas: Nitrogen-Fixing Trees for Adverse Sites. 1984. ICE, Manual number FC046.



Carter, Vernon Gill, and Dale, Tom 1981. Topsoil and Civilization. Norman, Okla.: University of Oklahoma Press

Combe, J 1982. "Agroforestry Techniques in Tropical Countries. Potential and Limitations." Agroforestry Systems. 1: 13-27

Cultivation of Neglected Tropical Fruits With Promise' 1976. ICE, Manual number AG138.

Curran, H. 1976. "Giant Ipil-ipil: Green Gold for the Tropics " US Peace Corps., mimeographed.

Domingo, Ireneo, L. 1981. "Agroforestry and Albizia Falcataria in PICOP." Paper presented at the Workshop on Agroforestry and Fuelwood Production, East-West Center, Honolulu, Hawaii.

Doneen, L.D., and Westcot, D.W. 1984. Irrigation Practice and Water Management. 1 Rev 1. Rome: Food and Agriculture Organization of the United Nations.

Douglas, J.S., and de J Hart, R. A., 1976. Forest Farming. Towards a Solution to Problems of World Hunger & Conservation. Emmaus, Pa.: Rodale Press.

Engineering Field Manual of Conservation Practices. 1979 ICE, Manual number FC04.

Establishment Techniques for Forest Plantations 1978 ICE, Manual number FC06.

Eucalypts for Planting. 1979. ICE, Manual number FC122.

Evans, J. 1982. Plantation Forestry in the Tropics. Oxford: Clarendon Press.

FAO (Food and Agricultural Organization of the United Nations). 1982. "Conservation and Development of Tropical Forest Resources." Rome, Italy.

FAO (Food and Agricultural Organization of the United Nations). 1980. Forestry for Rural Communities, Rome, Italy. 52 pp.

FAO (Food and Agricultural Organization of the United Nations). 1977. Forestry for Local Community Development. Rome, Italy. FO: MISC/77/22.

Ffolliott, P.F., and Thames, J.L. 1982. "Environmentally Sound Small-Scale Forestry Projects. Guidelines for Planning. Coordination in Development." Volunteers in Technical Assistance, ICE, Manual number FC123.

Fillion, Jacob, and Weeks, Julius. 1984. Agroforestry In-Service Training: Asia and the Pacific Islands. Washington, D.C.: Peace Corps Information Collection and Exchange. Training Manual No. T-16.

Filus, A.S. 1982. "Economic Aspects of Agroforestry." Agroforestry Systems, 1: 29-39.

Firewood Crops: Shrub and Tree Species for Energy Production. 1980. ICE, Manual number FC42.

Firewood Crops, Vol. 2: A Report of an Ad Hoc Panel of the Advisory Committee on Technology Innovation. 1983. ICE, Manual number FC045.

Forestry Case Studies. 1981. ICE, Manual number CS3.

Forestry for Food Collection. 1979. ICE, Manual number FC35.

Forestry Support for Agriculture through Watershed Management, Windbreaks and other Conservation Actions. ICE, Manual number FC12.

Foth, H.D., and Turk, L.M. 1972. Fundamentals of Soil Science. 5th ed. New York: John Wiley & Sons, Inc.

Fruit and Vegetable Juice Processing Technology, 1980. ICE, Manual number AG019.

Garner, R. J., and Chandhri, Saud Ahmed. 1976. "The Propagation of Tropical Fruit Trees." Horticultural Review no. 4. FAO reprint 1985.

Gittinger, J. Prince. 1982. Economic Analysis of Agricultural Projects. 2d ed. Baltimore: Johns Hopkins University Press for the World Bank.

Gregersen, H.M. 1980. "Environmental Constraints versus Economic Gains in Tropical Forest Utilization and Conservation." In Mergen, F., ea., 1980, Tropical Forest Utilization and Conservation: Proceedings of an International Symposium. April 15-16, Yale University, New Haven, Conn.

Greenland, D. J. 1975. "Bringing the Green Revolution to the Shifting Cultivator." Science, Volume 180, pp. 841-844.

Guevarra, A. B. 1976 Management of Leucaena Leucocephala. University of Hawaii.

Guidelines for Watershed Management. 1977. ICE, Manual number FC016.

Hadley, M. and Lanly, J. 1983. "Tropical Forest Ecosystems: Identifying Differences, Seeking Similarities." Nature and Resources, 19(1): 2-19.

Haines, S. G. and D. S. DeBell. 1979. "Use of Nitrogen-fixing Plants to Improve and Maintain Productivity of Forest Soils." In Proceedings: Impact of Intensive Harvesting on Forest Nutrient Cycling, SUNY, Syracuse, New York.

Handling, Transportation and Storage of Fruits and Vegetables, Volume 1: Vegetables and Melons. 1979. ICE, Manual number AG023.

Handling, Transportation and Storage of Fruits and Vegetables, Volume 2: Fruits and Tree Nuts. 1982. ICE, Manual number AG026.

Hartman, H.T., and Kester, D.E. N.d. Plant Propagation: Principles and Practices. Englewood Cliffs, N.J.: Prentice Hall.

Hopitan, Jose C. 1975. Common Methods of Propagating Fruit Plants. Agrix Publishing Corporation.

How to Make Tools. 1980. ICE, Manual number R35.

Hufschmidt, M.M., James, D.A., Meister A.M., Bower B.T., and Dixon J.A. Forthcoming. Environment, Natural Systems and Development: An Economic Valuation Guide. Baltimore: John Hopkins University Press.

Jaiyebo, F.O. and A. W. Moore. 1964. "Soil Fertility and Nutrient Storage in Different Soil-Vegetation Systems in a Tropical Rain-Forest Environment." Trop. Agriculture (Trin) 41: 129-139.

Jordan, C.F., and Farnworth, E.G. 1982. "Natural vs Plantation Forests: A Case Study of Land Reclamation Strategies for the Humid Tropics." Environmental Management, 6(6): 432-492.

Jordan, C.F., and Farnworth, E.G. 1980. "Agroforestry and the Development of Tropical Forestry." International Council for Research on Agroforestry, Nairobi, Kenya.

King, K.F.S. 1979. "Agroforestry and the Utilization of Fragile Ecosystems." Forest Ecology and Management, 2:161-168.

Lamb, A.F.A. 1969. "Artificial Regeneration within the Humid Lowland Tropical Forest." Commonwealth Forestry Review. 48(1): 41-53.

Leonard, Dave. 1980. Soils, Crops, and Fertilizer Use. Washington, D.C.: Peace Corps Information Collection and Exchange. Reprint No. R - 8.

Leucaena: Promising Forage and Tree Crop for the Tropics. National Academy of Sciences (NAS), 1977. ICE, Manual number FC15.

Little, E.L. Jr. 1983. Common Fuelwood Crops. A Handbook for their Identification. Morgantown, West Virginia: Communi-Tech Associates.

MacDaniels, L.H. and Lieberman, A.S. 1979. "Tree Crops: A Neglected Source of Food and Forage from Marginal Lands." Bioscience, 29(3): 173- 175.

Manual of Reforestation and Erosion Control for the Philippines. 1975. ICE, Manual number FC017.

Manual on Soil and Water Conservation. 1954. ICE Manual number R38.

Mongi, H.O. 1979. Agroforestry Extension. Needs and Strategy. International Council for Research in Agroforestry.

Nair, P.K.R., Fernandes, E.C.M., and Wambugu, P.N. 1984. "Multipurpose Leguminous Trees and Shrubs for Agroforestry." Agroforestry Systems.

National Academy of Sciences. 1980. Shrub and Tree Species for Energy Production. Washington, DC.

National Academy of Sciences. 1977. Tropical Legumes: Resources for the Future. Washington, DC.

Nye, P. H. and Greenland, D. J. 1964. "Changes in the Soil After Clearing Tropical Forest." Plant and Soil, 21(1): 101-112.

Orchard Management. 1969. ICE, Manual number R31.

Parfitt, R. L. 1976. "Shifting Cultivation--How it Affects the Soil Environment." Harvest, 3: 2.

Planting for the Future: Forestry for Human Needs, 1979. ICE, Manual number FC41.

Plumwood, V. and Routley, R. 1982. "World Rainforest Destruction--The Social Factors." The Ecologist, 12(1): 4-21.

Poore, M.E.D. 1983. "Replenishing the World's Forests: Why Replenish World Forests, Past, Present, and Future." Commonwealth Forestry Review, 62(3): 163-168.

Ruthenburg, H. 1980. Farming Systems in the Tropics. Oxford: Clarendon Press.

Sanchez, P.A. 1976. Properties and Management of Soils in the Tropics. New York: John Wiley and Sons.

Seeber, G. and A. Agpaoa. 1976. "Forest Tree Seed." In Manual of Reforestation and Erosion Control in the Philippines. H. J. Weidelt ed. Eschborn, Germany: German Agency for Technical Cooperation.

Sinden, J. A. and A. C. Worrell. 1979. Unpriced Values: Decisions Without Market Prices. New York: John Wiley and Sons.

Spears, John. 1982. "Preserving the World's Forest: Tropical Reforestation: An Achievable Goal?" Commonwealth Forestry Review, 62(3): 201-217.

Spears, J.S. 1980. "Small Farmers or the Tropical Forest Ecosystem?" In Mergen, F., ea., 1980, Tropical Forest Utilization and Conservation: Proceedings of an International Symposium. April 15-16, Yale University, New Haven, Conn.

Spurgeon, D. 1979. "Agroforestry: New Hope for Subsistence Farmers." Nature. 280: 533-534.

Stewart, P.J. 1981. "Forestry, Agriculture, and Land Husbandry." Commonwealth Forestry Review, 60(1): 29-34.

Strand, S.S. 1976. "Woodstock: An Integrated Farm/Forestry Management Project." New Zealand Journal of Forestry, 21(1): 36-42.

Textbook of Fish Culture. 1970. ICE, Manual number FH026.

The Propagation of Tropical Fruit Trees. 1976. ICE, Manual number FC111.

Tilapia: A Guide to Their Biology and Culture in Africa. 1979. ICE, Manual number FH020.

Tisdale, Samuel L., and Nelson, Werner L. 1975. Soil Fertility and Fertilizers. 3rd ed. New York: Macmillan.

Torquebiau, E. 1984. "Man-made Dipterocarp Forest in Sumatra." Agroforestry Systems, 2: 102- 127.

Tree Planting Practices in Tropical Asia. 1983. ICE, Manual number FC119.

Tropical and Subtropical Fruits, Composition, Properties and Uses. 1980. ICE, Manual number AG027.

Tustin, J.R., Knowles, R.L., and Klomp, B.K, 1979. "Forest Farming: A Multiple Use Production System in New Zealand." Forest Ecology and Management, 2: 169- 189.

UNESCO/UNEP/FAO. 1978. Tropical Forest Ecosystems.

U.S. Department of Agriculture. N.d. Fireman's Handbook. Washington, D.C: USDA, Forest Service, FSH 5109.12

Wadsworth, F.H. 1980. "Management of Forest Lands in the Humid Tropics under Sound Ecological Principles." In Mergen, F., ea., 1980, Tropical Forest Utilization and Conservation: Proceedings of an International Symposium. April 15- 16, Yale University, New Haven, Conn.

Watson, Harold. 1981. Home Gardens. Mindanao: Baptist Rural Life Center.

Weber, Fred. 1983. Reforestation in Avid Lands. ICE, Manual number M5. Washington, D.C.: The Peace Corps.

Weidelt, H.J., ed. 1976. "Establishment, Maintenance and Protection of Forest Plantations." In Manual of Reforestation and Erosion Control in the Philippines, Eschborn, Germany: German Agency for Technical Cooperation.

Wiersum, K.F. 1980. "Possibilities for Use and Development of Indigenous Agroforestry Systems for Sustained and Use of Java." Tropical Ecology and Development, 515-521.

Zaltman, F. and Duncan, R. 1977. Strategies for Planned Change. New York: John Wiley and Sons.

## **Appendix A. List of International Organizations for Resource Assistance**

### **List of International Organizations for Resource Assistance**

Appropriate Technology Development Institute  
P.O. Box 793  
Lae, Papua New Guinea

Australian Conservation Center  
672 B Grenferrie Road  
Hawthorn, Victoria  
Australia 3122

Australian National Focal Point  
INFOTERRA  
Environment Studies Branch  
Department of Home Affairs & Environment  
P.O. Box 12522

Canberra, Australia 2601

Claudia Monge  
INFORAT  
CATIE  
Turrialba, Costa Rica

College of Tropical Agriculture & Human Resources  
Publications Office  
University of Hawaii  
Honolulu, Hawaii 96822

Environment & Policy Institute  
East-West Center  
1777 East West Road  
Honolulu, Hawaii 96848

Information Collection & Exchange (ICE)  
United States Peace Corps  
1990 K Street, NW  
8th Floor  
Washington, DC 20526

Institute of Pacific Island Forestry  
1151 Punch Bowl Street  
Honolulu, Hawaii 96813

Institute of Tropical Forestry  
Post Office Box AQ  
Rio Piedras, Puerto Rico 00928

International Council for Research in Agroforestry  
Information & Documentation Section  
P.O. Box 30677  
Nairobi, Kenya

International Institute for Environment & Development  
1717 Massachusetts Avenue, NW  
Suite 302  
Washington, DC 20036

International Society of Tropical Foresters  
5400 Groevenue Lane  
Bethesda, MD 20814

John Seed  
Rainforest Information Center  
P.O. Box 368  
Lismore, Australia 2480

Liklik Buk  
Information Center  
P.O. Box 1920  
Lae, Papua New Guinea

National Academy of Sciences  
2101 Constitution Avenue, NW  
Washington, DC 20418

NIFTAL Project  
P.O. Box 0  
Paia, Hawaii 96779

Nitrogen Fixing Tree Association  
P.O. Box 680  
Waimanaio, Hawaii

Oxford University  
Commonwealth Forestry Institute  
Oxford, England

Total Environment Center  
18 Argyle Street  
Sydney, Australia

Tropical Products Institute  
58/62 Gray's Inn Road  
London WC1X 8LU  
England

Tropical Science Center  
Apartado 83870  
San Jose, Costa Rica

Volunteers in Technical Assistance (VITA)  
1815 N. Lynn Street  
Suite 200  
Arlington, VA 22209

World Wildlife Fund  
World Conservation Center  
1196 Gland, Switzerland

### **Publications Available from ICE**

The following publications are available free of charge to Peace Corps Volunteers and staff working in the field from the Office of Information Collection and Exchange (ICE). Requests for publications can be made through incountry program officers or directly to the following address:

United States Peace Corps  
Information Collection and Exchange (ICE)  
1990 K Street, NW  
8th Floor  
Washington, DC 20526

Note: In your letter to ICE, please identify yourself as a Peace Corps Volunteer, specify the country in which you are serving, briefly describe your work and secondary projects, and list the Whole ICE Catalog Number and title of each item you require. (Providing a short description of your work and projects will allow ICE staff to identify and send additional appropriate material if available.)

M0018	<u>Agricultural Extension</u>
FC067	Agroforestry Species for the Philippines
M0020	<u>Audio-Visual Communication Handbook</u>
R0033	<u>Bamboo as a Building Material</u>
FC046	<u>Casuarinas: Nitrogen-Fixing Trees for Adverse Sites</u>
M0023	Conservation Education: A Planning Guide
AG138	<u>Cultivation of Neglected Tropical Fruits with Promise</u>
FC151	A Directory of Selected Environmental Education Materials
FC004	Engineering Field Manual for Conservation Practices
FC149	Environmental Education about the Rain Forest
FC123	<u>Environmentally Sound Small-Scale Forestry Projects: Guidelines for Planning</u>
FC045	<u>Firewood Crops. Vol. 2: Shrub and Tree Species for Energy Production</u>
FC049	Forest and Watershed Development and Conservation in Asia and the Pacific

FC010	Forestry for Local Community Development
FC147	Indigenous Peoples, Environmental Protection and Sustainable Development
FC145	Management of Tropical Moist Forests: Ecological Guidelines
FC148	Managing Protected Areas in the Tropics
FC017	<u>Manual of Reforestation and Erosion Control for the Philippines</u>
R0038	<u>A Manual on Soil and Water Conservation</u>
R0031	<u>Orchard Management: Horticultural Practices for Peace Corps Volunteers</u>
R0073	Planning National Parks for Ecodevelopment: Methods and Cases from Latin America
R0062	Soil Conservation Techniques for Hillside Farms: A Guide for Peace Corps Volunteers
FH026	<u>Textbook of Fish Culture: Breeding and Cultivation of Fish</u>
FH020	<u>Tilapia: A Guide to Their Biology &amp; Culture in Africa</u>
AG027	<u>Tropical and Subtropical Fruits: Composition, Properties and Uses</u>

### Appendix B. Nitrogen-Fixing Trees: General Information

**Table 1. Ecological Requirements, Impacts, Uses, and Management of Nitrogen-Fixing Legume Trees**

Items	<u>Cassia siamea</u>	<u>Acacia auriculiforms</u>	<u>Pithecellobium dulce</u>	<u>Mimosa scabrella</u>	<u>Prosopis alba</u>
<b>Species identification</b>					
Scientific name	<u>Cassia siamea</u>	<u>Acacia auriculiforms</u>	<u>Pithecellobium dulce</u>	<u>Mimosa scabrella</u>	<u>Prosopis alba</u>
Synonym			<u>Mimosa dulces</u>	<u>Mimosa bracatinga</u>	
Common name	Yellow cassia, muong, minjri, kassof-tree, angkanh, cassia		Manila tamarind, Madras torn, quachamil, kamachi, blackbead, opiuma (Hawaii)	Bracatinga	Algarrobo blanco, tacu, ibopi
<b>Distribution</b>					
Country(ies) of origin	Southeast Asia from Indonesia to Sri Lanka	Papua New Guinea, Torres Strait Islands, Northern areas of Australia	From the Pacific slopes of Mexico and S. Cal. thru all of Central America to Colombia and Venezuela	Parana region of Southeastern Brazil	
Current geographic location	Southeast Asia, West Indies, Central America, Florida, East and West Africa; Southern Africa	Papua New Guinea, Torres Strait Islands, North Australia, Indonesia, Tanzania, India, Malaysia, Nigeria	SW U. S., Central America, Philippines, India, Sudan, Florida, Tanzania, Cuba, Jamaica, Hawaii, Puerto Rico, St. Croix	Brazil, Portugal, Zaire, Spain, Mexico, Senegal, Ethiopia, El Salvador, Jamaica, Argentina, Venezuela	Arid zones of Northern Argentina, Paraguay, Bolivia
<b>Latitudinal range</b>		<b>Tropics</b>	<b>Tropics/subtropics</b>	<b>Humid tropics</b>	

<b>Environmental requirements</b>					
Soil	Deep, well-drained, rich soil; tolerates soils with laterite and limestone	Wide range of deep or shallow soils; pH 3.0 to 9.5	On most soil types: clay, colitic limestone, barren sands, wet sands with brackish water table	Well-drained soils; not selective but wet soils stunt its growth	Sands with high clay; tolerates some salt
Temperature	Cannot withstand cold but thrives in tropical heat	Humid tropics, 26 to over 30°C	Warm tropical and subtropical	Cool subtropical but can grow in warm/dry areas	Not frosty hardy 15°C - mean temp
Altitude	Lowland	Up to about 600 m	Mexico: Up to 1,800 m Burundi: Up to 1,500 m	2,400 m	100-500 mm; resistant to drought
Rainfall/moisture	Most prevalent in monsoonal areas with 1,000 mm or more and with 4-5 months dry season	1,500-1,800 mm with 6 months dry season	450-1,800 mm/yr; resistant to drought		
<b>Environmental impacts</b>					
On soil erosion		Roots can hold soil in place; used to stabilize slopes in Indonesia			Windbreaker
On soil moisture and water table		Soil cover crop and shade tree to maintain soil moisture			
On soil nutrients				Nitrogen-rich leaves for humus	Nitrogen fixer
On undergrowth			Shades out more desirable forage plants		
<b>Economic uses</b>					
Mainstem and branches	Firewood, timber for cabinet-making	Fuelwood, wood pulp, charcoal	Firewood; general construction purposes; posts	Firewood, pulp for paper	Firewood, wood for flooring, wine casks, shoe-lasts, and paving blocks
Fruits and seeds			Pods for food and drinks, for fodder, seeds with oil for food and soap-making		Pods for cattle; milled seeds for human food
Leaves			Fodder		



Other	Host for sandalwood	Bark contains 13% water soluble tannin; shade tree	Shade, hedges, ornamental, bark extract for tanning, gum from bark, shelterbelt, flowers for honey	Fertilizer: ornamental, fence	Windbreak and roadside planting
<b>Productivity</b>					
Wood yield	Up to 15 m <sub>3</sub> /ha	Indonesia: 17-20 m <sub>3</sub> /ha/yr Malaysia: 17-20 m <sub>3</sub> /ha/yr	Can reach a height of 10 m in 5-6 years	14 mos.: 5 m tall 2 yrs.: 8-9 m tall 3 yrs.: Up to 15 m	In Argentina: 10 years old plantations give 7 m <sub>3</sub> /ha/yr spaced 2 x 2 m on a fair site
Hydrogen yield					
<b>Management</b>					
Establishment, spacing, timing	Direct seeding, seeds require no treatment if they are fresh; old seeds must be scarified with hot water or sulfuric acid	Direct seeding and nursery-raised seedlings	Cuttings or seeds	Direct seeding at 3-4 seeds in shallow depression (3-4 cm) at distances of 2-3 m apart	Direct seeding but seedling transplanting is better at 2 x 2 x 40 cm when seedlings are 2-3 months old; plant in spring or the onset of rainy season
Tending care	Weeding in the first year or so; protect from browsing live-stock or wildlife	weeding during early years; treat seeds with boiling water and soak for 24 hours			Inoculate seeds with mesquite rhizobia
Pest and disease	Susceptible to attack by scale insects	Zanzibar: Seedlings attacked by insects and nematodes	Leaf spot disease: host for thornbug; defoliating and boring insect nests		Eruchid beetles attack seeds in pods
Harvesting	Yields for 4 or 5 rotations; every 7 yrs. harvesting.				
Regeneration	Coppices readily	Coppices poorly; regeneration thru seedlings	Coppices vigorously		

Table 1. (cont 1)

Items	<u>Leucaena leucocephala</u>	<u>Prosopis chilensis</u>	<u>Sesbania bispinosa</u>	<u>Sesbania grandiflora</u>	<u>Albizia lebbek</u>
Species identification					

Scientific name	<u>Leucaena leucocephala</u>	<u>Prosopis chilensis</u>	<u>Sesbania bispinosa</u>	<u>Sesbania grandiflora</u>	<u>Albizia lebbek</u>
Synonym	<u>Leucaena glauca</u>		<u>Sesbania aculeata</u>	Aqeti <u>grandiflora</u>	<u>Mimosa lebbek</u> , <u>mimosa</u>
Common name	Leucaena, ipil-ipil, lamtora, guaje, yale, auxin, leadtree	Algarroba, kiawe, mesquite, algarrobo blanco, algarrobo de Chile	Dahaincha, prickly sesban	Agati, bacule, katurai, turi, gallito, chogache, August flower	Lebbek, karana, kokko frywood
<b>Distribution</b>					
Country(ies) of origin	Midlands of South Mexico, Guatemala, Honduras, El Salvador	Peru, Chile, Eastern Argentina	Tropical/subtropical areas of the Indian subcontinent	India, Malaysia, Indonesia, Philippines	India, Pakistan, Bangladesh, Burma
Current geographic location	Mexico, Pac, Islands, Indonesia, Popua New Guinea, Malaysia, East and West Africa, South America, Philippines	South America, Hawaii	Tropical Africa, South-east Asia, China, West Indies	Asia, West Indies, Central and South America, Mauritius	India, Bangladesh, Pakistan, tropical/subtropical North Africa, West Indies, South America, Southeast Asia
<b>Latitudinal range</b>	<b>Tropics/subtropics</b>		<b>Tropics/subtropics</b>	<b>Tropics/subtropics</b>	<b>Tropics/subtropics</b>
<b>Environmental requirements</b>					
Soil	Grows well in neutral or alkaline soils; sandy clay to sandy loam; does not like acidic soils		Grows on saline and alkaline wastelands and wet, almost waterlogged soils	Wide range including black poorly structured clay	Moist, well-drained loam; tolerates sea sprays
Temperature	Tropical/subtropical; frost kills it	Withstands high desert temp.; requires 27°C	Tropical/subtropical	Tropical conditions; frost sensitive	Tolerates light frost and drought after first year
Altitude	Below 500 m	Peru: Up to 2,900 m India: 340-1,230 m	Up to 1,200 m	Up to 800 m	India: Sea level to 1,600 m
Rainfall/moisture	600-1,700 mm 400-800 mm (Philippines)	200-400 mm/year; very resistant to drought	550-1,100 mm; resistant to drought	More than 1,000 mm with a few months of dry season	500-2,000 mm with wet summers
<b>Environmental impacts</b>					
On soil erosion	Suppresses undergrowth in the first 3-4 years		For erosion control	Used to reforest eroded land	Good soil binder

On soil moisture and water table	Roots break subsoils improving soil penetration				
On soil nutrients	Nitrogen fixer; nitrogen from foliage	Probably N-fixer	Fertilizer from nodules and leaves	Nutrients for litterfall and nitrogen fixation	Nitrogen fixer
On undergrowth	Shade out undergrowth during the first 3-4 years				
<b>Economic uses</b>					
Mainstem and branches	Firewood/charcoal, lumber/timber, pulp and paper roundwood construction material, fence posts, banana props, direct fuel source for steam-powered generators	Firewood; wood is easy to work finishing smoothly and taking a natural	Firewood; pulp and paper; cordage fiber for fishing nets, gunny sacks, and sail	Firewood, pulp and paper, roundwood, gum from bark, tanning agent from bark	Fuelwood, wood for furniture and houses; carves and polishes well
Fruits and seeds	Pods for food; seeds for beverage, medicine		Gum for textile and paper products	Pods for fodder, human food	Fodder
Leaves	Fodder, N-source	Pods are excellent food	Fodder for cattle; green manure	Vegetables, fodder, green manure	20% protein when young; green manure
Other	Shade and ornamental, windbreak, tannin from barks	Fodder	Windbreak, shade, hedge, cover crop	Ornamental, shade, windbreak, fence	Shade, nectar for honey; ornamental
<b>Productivity</b>					
Wood yield	30-40 m <sub>3</sub> /ha/yr (scan) Philippines: 24-312 m <sub>3</sub> /ha/yr		15 bone-dry t/ha/yr or more where more than one crop/yr can be harvested	20-25 m <sub>3</sub> /ha/yr	In 10-15 years rotation: 5 m <sub>3</sub> /ha/yr
Nitrogen yield	Leaves contain 0.5-1% of the green weight or 4.3% of the dry weight in N				
<b>Management</b>					

Establishment, spacing, timing	Seeds in hot water, then soak 2-3 days; direct seeding or by seedlings; plant at the start of rainy season at 2 _ 2 m or 2 _ 3 m for bigger wood yield	Propagated by seeds; seeds must be scarified in hot water or sulfuric acid before planting	Establishes easily by direct seeding; no seed treatment required	Propagates easily by cuttings or seedlings; no seed treatment required	Direct seeding; also stem or root shoot cuttings; boil seeds and soak for 24 hours
Tending care	Weed control, inoculate soil, keep soil moist		Can compete with weeds	Requires little maintenance	Weeding during the first 2 years
Pest and disease control	Use semesan, ceresan, ferbam, arasan for seeds; damping off and fungal diseases	Bruchid beetles destroy seeds		Susceptible to nematodes; also damaged by birds and grasshoppers	Protect from browsers; in India, some fungus attack the leaves and pods
Harvesting	For fuelwood, cut when 4-6 years old		Two harvests a year	3-4 years, although 2 years is okay	10-15 years rotation
Regeneration	Coppices well		Two harvests a year are possible	Coppices	Coppices fairly well

Table 1. (cont 2)

Items	<u>Gliricidia sepium</u>	<u>Calliandra calothyrsus</u>	<u>Acacia mearnsii</u>	<u>Acacia senegal</u>	<u>Acacia seval</u>
<b>Species identification</b>					
Scientific name	<u>Gliricidia sepium</u>	<u>Calliandra calothyrsus</u>	<u>Acacia mearnsii</u>	<u>Acacia senegal</u>	<u>Acacia seval</u>
Synonym	<u>Gliricidia maculate</u>	<u>Calliandra confuse</u>	<u>Acacia mollissima</u>	<u>Acacia verek</u>	<u>Acacia fistula</u>
Common name	Madre de cacao, mataraton, kakauati	<u>Calliandra</u>	Black or tan wattle	Gum acacia, hashab, gum arabic tree	Talh, shittim wood
<b>Distribution</b>					
Country(ies) of origin	Mexico, Central America, Northern South America	Central America	Victoria, S. Australia, New South Wales, Queensland, Tasmania	Southern Sahara, Sahelian zone from Senegal to Somalia, Sudan	Africa

Current geographic location	Mexico, C America, S. America (Brazil), West Indies, Asia, Southern Florida	C America, Indonesia, E. Africa, India, Sri	New Zealand, S., C. and Pakistan, Nigeria Lanka, parts of C America, Indonesia	Sudan, Senegal, India,	Africa, Egypt
<b>Latitudinal range</b>	<b>Humid tropics</b>	<b>Humid tropics</b>	<b>Tropical highlands</b>		
<b>Environmental requirements</b>					
Soil	Does well in moist or dry soils, even with limestone	Can grow on infertile and heavy compacted clay with poor aeration	Cannot tolerate calcareous soil; can grow on poor soils	Grows in sand, clay except where rainfall is high (800+ mm/yr) which will cause water-logging	Often found on stony ground; grows on most soil types even heavy clay
Temperature	22-30°C		Cool winters; slow growth on high temp.; frost tolerant	Sudan 14-43°C India (-4 to 48°C)	Hot
Altitude	Up to 1,600 m but mainly below 500 m	150-1,500 m	Australia: Up to 1,100 m Indonesia: Up to 110 m Natal and South America: 300-1,100 m	100-1,700 m	Tropics: Up to 2,100 m; a lowland tree
Rainfall/moisture	1,500-2,300 mm or more	Over 1,00 mm but can withstand drought for several months	500-700 mm	Range: 200-800 mm Opt.: 300-400 mm; resistant to drought	Drought tolerant; 350+ mm/year
<b>Environmental impacts</b>					
On soil erosion	Conserves ground water	Soil binder on slopes	Good on hillsides of up to 50-degree slope	Ideal for reclamation of refractory sites and sand dunes and wind erosion control	
On soil moisture and water table	Conserves ground water when it drops its heavy mantle of leaves	Provides ground cover to reduce evapotranspiration rate			
On soil nutrients	Nitrogen fixer	Ground cover improves soil; nitrogen fixer	Green manure	Nitrogen fixer	
On undergrowth		Chemicals from litterfall	Nitrogen fixer		
<b>Economic uses</b>					

Mainstem and branches	Fuelwood, wood for furniture, small articles, agricultural implements, tool handles, posts and heavy construction	Firewood	Fuelwood, roundwood, tannin from bark for leather products, pulpwood for wrapping paper	Fuelwood, charcoal, poles, agricultural implements	Firewood, lumber
Fruits and seeds	Flowers for bees			Pods for fodder; dried seeds for food	Pods and flower for fodder
Leaves	Green manure or ruminant feed	Fodder (7-10 t dry fodder/ha/yr)	Green manure	Feeds for camels, sheeps and goats	Fodder
Other	Fence, windbreak, shade, ornamental	Ornamental, firebreak, nectar for honey	Forage	Roots for ropes/nets; gum arabic source	Edible gum when fresh
<b>Productivity</b>					
Wood yield	8 m_/ha/yr	After first year: 5-20 m_/ha/yr after second year: 35-65 m_/ha/yr	10-25 m/ha/yr	5 m_/ha/yr (dense); 0.5-1 m_/ha/yr (sparse)	Slow growing
Nitrogen yield			21-28 t wet leaves; with 240-285 kg N		
<b>Management</b>					
Establishment, spacing, timing	Seeds or cuttings; seeds in hot water and soak overnight before planting	Seeds or seedlings for plantations; planting should be done at the start of the wet season transplant 4-6 most old seedlings at 1 _ 1 m or 2 _ 2 m	Direct seeding; dormancy of seeds is broken by immersing them in boiling water	From seeds; overnight soaking of seeds is effective	From seeds, large cuttings, nick or boil seeds briefly
Tending care		Treat seeds with hot water and soak for 24 hours		Weeding for first 2 years; protect from browsers	
Pest and disease	Termite resistant; aphids attack foliage which leaves to fall		Not serious but susceptible to attack under wet conditions with more than 3,000 mm rainfall/year	Pods: Insects Roots: Termites Seedlings-susceptible; mature-rests/ant	Resistant; felled logs may be severely damaged by wood borers
Harvesting		Can be harvested annually	7-10 years		
Regeneration	Coppices easily	Coppices readily	Coppices poorly	Coppices well	

SOURCES: "Firewood Crops" (NAS); "Tropical Legumes" (NAS).

**Table 2. Ratings of Uses and Environmental Adaptability of Some Nitrogen-Fixing Legume Trees**

Uses	Acacia auriculiforms	Acacia mangium	Albizia falcataria	Albizia lebbek	Calliandra calothyrsus	Dalbergia sisso	Gliricidia sepium	Leucaena diversifolia	Leucaena leucocephala	Samanea saman	Sesbania grandiflora
Human food	C*	C	C	C	C	C	B	C	A	B	A
Fuelwood	A	B	C	A	A	A	A	A	A	B	A
Poles	C	B	C	A	C	B	A	A	A	C	A
Sawnwood	C	A	A	B	C	A	C	C	A	A	C
Pulpwood	A	A	A	C	B	B	C	A	A	C	C
Woodcraft	C	B	C	A	C	A	B	B	B	A	C
Forage	C	C	C	A	B	B	A	A	A	B	A
Green manure	C	C	B	A	A	B	A	A	A	C	A
Environmental adaptability											
Acid soils	A	A	-	-	B	-	-	C	C	-	C
Drought	B	B	C	B	B	A	B	A	A	A	B
Coppicing ability	A	A	A	A	A	A	A	A	A	A	A
Minimum rain (mm/yr)	750	750	1,500	600	1,000	500	1,500	600	600	600	1,000

\* Ratings

A = Good

B = Fair

C = Poor

SOURCE: Brewbaker, J. R. Van Den Beldt, and K MacDicken, 1981

**Table 3. Properties of Some Nitrogen-Fixing Legume Trees**

Properties	Acacia auriculiforms	Acacia mangium	Albizia falcataria	Albizia lebbek	Calliandra calothyrsus	Gliricidia sepium	Leucaena diversifolia	Leucaena leucocephala	Samanea saman	Sesbania grandiflora
Specific gravity	0.68	0.65	0.33	0.58	0.65	0.75	0.55	0.54	0.52	0.42
Wood yield (cm/ha/yr)	15	30	40	5	50	8	25	45	15	22
Average height growth (m/yr)	2.6	2.5	5.0	1.4	6.0	2.5	4.0	4.5	2.5	3.3
Height at maturity (m)	30	30	45	30	10	10	20	20	45	10



Diameter at maturity (cm)	60	25	100	20	50	20	30	35	180	30
---------------------------	----	----	-----	----	----	----	----	----	-----	----

**NOTE:** The above growth figures are from trials in Hawaii and may be used as indicators only. Growth rates in other sites could vary widely from them.

**SOURCE:** Brewbaker, J., R. Van Den Beldt, and K. MacDicken, 1981.

## **Appendix C. Tropical Timber, Fuel, and Fruit Species**

### **Tropical Timber and Fuelwood Trees**

#### **Betulaceae**

*Alnus nepalensis*

#### **Family**

Betulaceae

#### **General Description and Distribution**

*Alnus* is a large tree with thick bark. It grows quickly and may fix atmospheric nitrogen. Native to Burma, the Himalayas, and China, it has been successfully propagated in the tropical upland forests of Hawaii.

#### **Use**

The wood is primarily used for firewood. It has a specific gravity of 0.32-0.37. It burns evenly but rapidly, and coppices well.

#### **Environmental Requirements**

The trees grow on cool, moist, tropical highland climates between 1,000-3,000 m in elevation. Soil moisture rather than soil type is a factor affecting growth.

#### **Propagation and Care**

The tree is best started in the nursery and then transplanted. Care should be taken to avoid damage caused by beetle larvae and borers.

#### **Burseraceae**

*Bursera simaruba*

#### **Family**

Burseraceae

#### **General Description and Distribution**

*Bursera* is an erect, straight tree when grown in the jungle but tends to be lower and broader when planted in the open. It reaches 20-30 m with a trunk diameter of 75 cm. It is highly esteemed in Central America and Caribbean for its use as fuel and fence posts.

The tree is virtually unknown outside of the Americas.

#### **Use**

The wood is used for firewood and charcoal. Other uses include boxes and crates, soles, light furniture, and toothpicks. In the Caribbean it is used for live fences. In the southern United States it is planted as an ornamental.

## **Environmental Requirements**

The tree requires a tropical to subtropical climate, and grows between from sea level to 1,800 m. Rainfall should be no less than 500 mm a year. It has no particular soil requirements.

## **Propagation and Care**

The tree regenerates itself through natural seeding, and is tolerant of weeds. Strong winds will often snap branches allowing the infestation of fungus. Cut logs should be thoroughly dried or treated with fungicide.

### **Casuarina littoralis**

*Casuarina equisetifolia*

### **Common name**

Casuarina, she oak, Australian pine, ironwood, whistling pine, agoho (Philippines), nokonoko (Fiji)

### **Family**

Casuarina littoralis

## **General Description and Distribution**

Rapid growing, carefree species for sites and climates as varied as coastal sand dunes, high mountain slopes, hot humid tropics and semi-arid regions. The species is salt tolerant and adaptable to moderately infertile soils. Although the species is not a legume, it has the ability to form root nodules and fix nitrogen. The tree can attain heights of up to 50 m, with diameters of up to 1 m. It normally reaches a height of 15-25 m tall.

Casuarina species are native to the Southern Hemisphere from tropical India to Polynesia, It has thrived when introduced in Pacific Island countries.

## **Use**

The wood is primarily used as firewood. It burns with great heat and has been called the best firewood in the world. It is used for both domestic and industrial fuel. It has a specific gravity of 0.8-1.2 and a calorific value of 4,950 kcal per kg. In the Philippines the tree commonly grows two to three meters a year. The yield per hectare varies from 75-200 tons on a rotation of seven to ten years, with a spacing between plants of approximately two meters.

Because the timber is strong, it is also used for house posts, rafters, electric poles, mine props, roofing shingles, tool handles, oars, etc. It is also used to control erosion on soils with high concentrations of salt. A two to three deep belt of Casuarinas is an effective wind break.

## **Environmental Requirements**

Casuarina thrives in a temperature range of 10 to 33 degrees centigrade. It can be planted from sea level up to 1,500 m, with an annual rainfall between 700 to 2,000 mm. The species has known to survive with as little as 200 to 300 mm or as much as 5,000 mm.

Since the species has root nodules containing nitrogen-fixing microorganisms it is not dependent on soil nitrogen for good growth. It tolerates calcareous and slightly saline soils, but does not do well on heavy clay soils.

## **Propagation and Care**

Seedlings are normally transplanted to the field. Transplanting is normally carried out at the beginning of rainy season in order to ensure adequate moisture. It is necessary to control weed growth until the

trees are firmly established. Inoculate the seeds prior to planting. Because the species is aggressive it is necessary to control growth in order to protect other species in the area planted.

## **Combretaceae**

*Terminalia catappa*

### **Family**

Combretaceae

### **General Description and Distribution**

*Terminalia* is a medium-sized tree with large reddish leathery, leaves. It bears edible, almond shaped fruits. Because it is resistant to salt spray, it is found growing along coastal areas.

The tree is found throughout the islands of the Tropical Pacific.

### **Use**

Although the tree is commonly used for shade and ornamental purposes, it also makes a good firewood. It has a specific gravity of 0.59 and can be expected to yield approximately 22.5-36.0 to a hectare over a ten year period.

The wood is also attractive and hard which makes for sturdy furniture, tools, boats, and construction material. The seeds are often eaten roasted or raw, and also produce oil. The bark, leaves, roots, and fruits contain tannin. The leaves have been successfully fed to silkworms.

Because the tree is tolerant of saline conditions, it has been used to control beach erosion.

### **Environmental Requirements**

*Terminalia* grows best in areas with rainfall between 1,500 mm to 10,000 mm. It can withstand flooding as well as drought. It is found growing up to 1,800 m, and in various types of soil.

### **Propagation and Care**

Direct seeding is the most common method of propagation, although seedlings are also easily transplanted from a nursery. If direct seeding the seeds should be sown during the onset of the rainy season. Germination normally occurs after 2-3 weeks. Once established, the tree shades out weeds. Care should be taken to control the spread of its seeds, as it soon becomes a weed and shades out other favorable species.

## **Elaeocarpaceae**

*Muntingia calabura*

### **Family**

Elaeocarpaceae

### **General Description and Distribution**

*Muntingia* is a small fast-growing evergreen tree with a dense, spreading crown and drooping branches. It reaches 8-13 m tall with a trunk 8.5-20 cm in diameter. It bears a cherry like fruit in 1.5-2 years from seed. The fruits are 1 cm wide, round, and deep red, with a sweet light-brown pulp filled with small seeds

It is native to Central and South America, but has been planted throughout the Pacific Islands

### **Use**

The tree is primarily used for firewood. It ignites quickly, and produces an intensely hot flame with little smoke. It is also used for beautification and shading purposes. The fruit produced by the tree is sweet and juicy, It has also been considered for use as paper pulp.

### **Environmental Requirements**

The tree grows best in humid, tropical areas at an altitude between 500-1,300 m. Rainfall requirements range between 1,000-2,000 mm

The tree adapts easily to many different types of soil types. In the Pacific it is recommended for planting in the sandy coral soils of the low islands and atolls.

### **Propagation and Care**

The tree is best established when cuttings are planted. Weeds are controlled by the dense tree canopy. It is recommended the tree be pruned on an annual basis as the branches tend to break under strong winds. It also becomes a nuisance if its growth is not controlled.

### **Leguminosae**

*Derris indica*

### **Family**

Leguminosae

### **General Description and Distribution**

A medium-sized, deciduous tree with numerous pods, each containing a single seed. The species is generally used for fuel wood, yet is also valuable as a check against erosion.

Although native to the Indian subcontinent, it can also be found in Southeast Asia and the Pacific Islands.

### **Use**

The wood is primarily used as firewood. It has a caloric value of 4,600 kcal per kg. The trees often reach adult height in 4 to 5 years. The leaves of the tree are also used as fodder for animals. Pasture grasses also grow well in its shade. When dried, the leaves are used to protect stored grains because the odor repels insects. The leaves are also ploughed into the soil as a green manure and are thought to control insect predation on crops. The oil from the seed is used as a lubricant as well as fuel in kerosene lamps. The remaining presscake can be fed to poultry, or used as an insecticide.

### **Environmental Requirements**

*Derris indica* withstands temperatures from 0 to 50 degree centigrade, and thrives up to 1,200 m above sea level. Approximately 500 to 2,500 mm per year of rainfall is required. The tree will grow in almost all soil types. It is highly tolerant of saline conditions.

### **Propagation and Care**

The tree can be propagated from direct seeding or cuttings. A cutting placed directly in the ground will develop roots. Shade nor crowding are problems. The species is known to host both insects and fungus. Care should be taken in where the tree is planted. Its aggressive root system will create serious weed problems.

*Gliricidia septum*

### **Common Name**

Madre de cacao

## Family

Leguminosae

## General Description and Distribution

A small tree that grows up to 10 m high and 30 cm or less in diameter. It is a fast growing species that grows well in congested areas. It is good as fuelwood, fixes nitrogen, and enriches poor soils.

It grows in the West Indies, Africa, Asia, and South America. It is especially popular in the Philippines.

## Use

Although it is an especially good firewood, *gliricidia septum* also produces fine furniture, and sturdy farm implements. It is also used as fence posts and construction material. The tree is especially appropriate as a living fence. Trimming the fence every other month provides luxuriant growth, green manure, and fodder for ruminants. The tree is toxic to other animals. The tree also provides excellent shade for coffee and cacao. The foliage can be cut and used as a green manure and mulch around the base of the trees. The flowers are also known to be a good forage for bees and thus can be used in conjunction with a honey bee operation.

## Environmental Requirements

The trees withstand temperatures from 22 to 30 degrees centigrade, and thrive up to 1,600 m above sea level. Approximately, 1,500 to 2,300 mm per year of rainfall is required. The tree will grow in moist and dry soil. Excessive alkalinity is not a limitation to growth.

## Propagation and Care

The tree can be raised by direct seeding. Soak the seeds in hot water overnight, and plant the next morning. The tree attracts aphids and ants. It is toxic to non-ruminants.

*Sesbania sesban*

## Family

Leguminosae

## General Description and Distribution

*Sesbania* is a shrub or small tree that grows 4.5-6 m high. It produces flowers and seedpods. It is a fast growing, short-lived tree that regenerates rapidly after pruning. It produces root nodules and fixes atmospheric nitrogen.

It is believed to be one of the first garden plants cultivated in Egypt. It is now grown in Asia.

## Use

The tree is used for firewood, food, fodder, wood, and fiber. When grown for firewood it has produced 30 tons per hectare. The flowers can be eaten as a vegetable. The leaves and branches are cut and fed to cattle. As a wood, it has been split and plaited into mats. It can also be used in the construction of roofs. It is often used as a substitute for bamboo. The bark is used in rope making.

The tree also makes an excellent wind break and provides shade for vegetable gardens, and other shade loving plants such as coffee. When intercropped, it provides nitrogen to the soil. Harvested leaves can be composted and mixed into a soil mixture for nurseries.

## Environmental Requirements

The species requires a mean temperature of 10 to 45 degrees Centigrade. It has grown up to an altitude of 1,200 m. Rainfall can vary between 350-1,000 mm annually.

It tolerates a wide range of soils, withstanding acid soil, flooding, and waterlogging.

### **Propagation and Care**

The tree can be propagated from seed. No pre-treatment is necessary. Weed during the first two or three months after emergence, and protect the seedlings from foraging animals.

### **Leguminosea (Mimosoideae)**

*Acacia auriculiformis*

### **Family**

Leguminosae (Mimosoideae)

### **General Description and Distribution**

Resilient, vigorously growing, small tree with a trunk up to 60 cm in diameter. It can reach a height of 30 m. Grows well on poor soils. The species is native to the savannas of Papua New Guinea, the islands of the Torres Strait, and the northern areas of Australia. It has been successfully propagated in Indonesia and Malaysia.

### **Use**

Large fuelwood plantations have been established in Indonesia. The species is well suited for fuelwood, with a high specific gravity (0.6-0.75) and a calorific value of 4,800-4,900 kcal per kg. The wood yield excellent charcoal that glows well and burns without smoke or sparks. The trees do not coppice well unless cut 50 cm above the ground. Cut over stands regenerate rapidly. The tree grows quickly even in unmanaged plots on poor soils. In Papua New Guinea, trees grew to 6 m in 2 years, with a diameter of 5 cm. The species is also a good source of pulpwood, and provides shade.

### **Environmental Requirements**

Thrives in humid climates with a temperature range between 26 and 30 degrees centigrade. It can also survive in dry areas. Its natural habitat has an average annual rainfall varying from 1,500 to 1,800 mm and a dry season of 6 months. It grows at altitudes up to 600 m. Soil is not a major concern. The tree will grow in sand dunes, shist, clay limestone, podsols, laterite, and lateritic soils. Because of nitrogen fixing nodules, it can survive on land very low in nitrogen.

### **Propagation and Care**

Plant can be established through direct seeding or nursery propagation. Because the seedlings are hardy, planting sites require very little preparation and maintenance. The plants are shade intolerant so it is important to clear weeds. Before sowing seeds scarify in boiling water, then soak for 24 hours. Insects and disease are not a problem in Indonesia.

*Acacia decurrens*

### **Family**

Leguminosae (Mimosoideae)

### **General Description and Distribution**

This acacia is a strong tree with upright growth, usually reaching 6-12 m in height. During flowering season slender seedpods are produced which snap open and throw the seeds. It produces good fuelwood and charcoal, as well as fixes nitrogen. It is native to Australia but has been successfully propagated in Southeast Asia and the Pacific.

### **Use**

The wood has a specific gravity of 0.50-0.70 and a caloric potential of 3,530-3,940 kcal per kg. It yields approximately 6-16 m per ha per year.

The wood is also used for construction materials, tanning, and as a shelterbelt.

### **Environmental Requirements**

Acacia flourishes in a temperature range of 12-25 degrees centigrade. The tree may grow up to 2,500 m above sea level. The mean annual rainfall required by the species is 9002,600 mm. It prefers deep, medium to well drained, moderately fertile soils.

### **Propagation and Care**

The tree spreads by seeds and root suckers. Seeds germinate in 7-10 days, and seedlings can be transplanted in 5- 7 months. Seeds should be soaked in water two hours prior to sowing. Weeds are not a problem as the tree quickly shades out any surrounding vegetation. The tree must be controlled in order to prevent its unchecked spread.

*Albizia falcataria*

### **Family**

Leguminosae (Mimosoideae)

### **General Description and Distribution**

Albizia, commonly known as falcata, is a fast growing tree that forms a large canopy with white flowers. Under favorable conditions it reaches 15 m in height in 3 years, 30 m in 10 years, and 44 m in 17 years.

It is native to Papua New Guinea, West Irian, the Solomon Islands, and the Moluccas. It is extensively grown on plantations in the Philippines and in Fiji.

### **Use**

The wood is used for firewood, but is better used for charcoal. It has a specific gravity of 0.24-0.49, and caloric content of 2,865-3,357 kcal per kg. On good soils growth can be up to 50 m per ha per year.

The wood is also processed into fiber and particle board. In the Philippines it is ground into pulp and made into newspaper. The tree is also used to provide shade for animals and heat sensitive crops. In Java it is planted in home gardens as a source of timber and firewood.

### **Environmental Requirements**

Falcata requires a temperature range of 22-29 degrees centigrade. It grows up to 1,500 m but performs best below 800 m. The best growth has been recorded in areas with annual rainfall of 4,500 mm and no prolonged dry season. Deep, well drained soils with high fertility provide the best medium for strong, healthy growth.

### **Propagation and Care**

The tree regenerates itself through natural seeding which takes place after 3 to 4 years. Prior to planting the seeds should be scarified in hot water, and wrapped in a wet sack or cloth for 24 hours. It is necessary to weed the area surrounding the seedling for at least one year.

The tree is exceptionally vulnerable to strong winds, which tend to break limbs. Broken limbs often result in fungal attack and death. Insects can also be a problem.

Because the tree has massive roots, it should not be planted on steep hillsides. Large roots tend to exacerbate soil erosion on steep slopes rather than prevent it.



*Calliandra calothyrsus*

### **Common name**

Calliandra

### **Family**

Leguminosae (Mimosoideae)

### **General Description and Distribution**

Fast growing tree with good coppicing ability. Rarely reaches more than 10 m tall and 20 cm in diameter and can be harvested after one year. The plant is native to Central America but has thrived in Southeast Asia.

### **Use**

The wood is primarily used as firewood. It has a specific gravity of 0.51-0.78, its calorific value is 4,500-4,750 kcal per kg, and its ash content is 1.8 percent. Indonesian experiments have shown growth of 2.5-3.5 m in six to nine months. After one year's growth it can be cut as short as 50 cm above the ground. Reported yields are 5-20 m<sup>3</sup> per ha. from the first cutting, and 35 to 65 m<sup>3</sup> in the following years. Because the species grows quickly, has dense foliage and a deep root system, it is particularly suited for controlling soil erosion on slopes and rejuvenating worn out land. In East Java, farmers rotate agricultural crops with calliandra, and feed the leaves to livestock.

### **Environmental Requirements**

The temperature range for the crop is unknown. It thrives between 150 and 1,500 m above sea level. Although the tree can survive drought, it grows best where rainfall exceeds 1,000 mm per year. The tree prospers on almost any type of soil.

### **Propagation and Care**

Plantations can be established by either direct seeding or by seedlings. Seeds should be planted at the beginning of the wet season in order to ensure emergence and fast growth. If transplanted, the seedlings should be moved when four to six months old. Plant spacing in the field is 2 m × 2 m or 1 m × 1 m. Scarify the seeds in hot water then soak in room temperature water for 24 hours. Be careful not to overplant in sensitive areas for the plant is so hardy it will be difficult to keep in check.

*Leucaena leucocephala*

### **Family**

Leguminosae (Mimosoideae)

### **General Description and Distribution**

The three principal types of *Leucaena* range in size from bushes to tall trees. All are thornless evergreens with feathery leaves, small white flowers and long green seed pods, which turn brown as they mature. *Leucaena* may grow less than 5 m to as high as 20 m. Although the tree is most productive in tropical and subtropical lowlands, it can also survive on rocky, steep slopes, in marginal soils and in well drained wet areas, as well as dry regions of the world. It not only provides fodder for livestock, but also produces fuel for fires and fertilizer for crops.

*Leucaena* originated in the midlands of southern Mexico and was introduced to the Pacific Islands, the Philippines, Indonesia, and Papua New Guinea.

### **Use**

*Leucaena* is extensively used in the Philippines for firewood. Large acreages have been planted to provide fuel for electric generators, factories, and agricultural-processing facilities. It is fast growing,

readily coppices, and has a calorific value of 4,200-4,600 kcal per kg. Annual leucaena yields have ranged from 24 to over 100 m<sup>3</sup> per hectare.

Leucaena has also proven to be an excellent feed for animals. Cattle, goats, water buffalo, and other animals have shown high weight gains when fed entirely on Leucaena. Although a sole diet of Leucaena can cause a mimosine related toxicity in the animals, this can be avoided with by supplementing the diet with other forages.

Because Leucaena is a nitrogen fixing legume, it helps enrich soil through its root nodules and from green manure produced by its leaves. Its foliage rivals manure in nitrogen content. In addition, its ability to thrive on steep slopes, in marginal soils, and in areas with extended dry seasons makes it an excellent species for reforestation programs.

### **Environmental Requirements**

Leucaena thrives in frost free areas below 500 m. It will grow above 500 m but without the same vigor. Annual rainfall requirements range between 600-1,700 mm, although it has been observed growing in areas with less than 250 mm. The plant tolerates a wide variety of soil conditions, but grows best in neutral or alkaline soils.

### **Propagation and Care**

Leucaena grows quickest when direct seeded or transplanted at the onset of rainy season. Prior to planting soak the seeds in hot water for 2-3 minutes. To further increase seed viability continue to soak the seeds in room temperature water for an additional 2-3 days. During the early stages of growth it is necessary to control weeds. Once the seedlings are established they shade out weeds. Leucaena is resistant to pests and disease.

*Mimosa scabrella*

### **Family**

Leguminosae (Mimosoideae)

### **General Description and Distribution**

A thornless shrub or slender tree that grows to 12 m high and 20-40 cm in diameter. It is rapidly growing tree that is little known outside of South America.

*Mimosa scabrella* is native to southeastern Brazil, but has been successfully propagated in other tropical and subtropical countries.

### **Use**

The tree is primarily used for firewood. In 14 months it grows to 5 m tall; in 2 years, 8-9 m; and in 3 years it sometimes attains a height of 15 m. Plantations have harvested in rotations as short as 3 years.

Other uses include pulp for writing paper, beautification, live fences, and green manure.

### **Environmental Requirements**

It is native to cool, subtropical plains, but can also survive in warm, drier areas. In Guatemala it flourishes at 2,400 m. The tree grows in many types of well-drained soils. Wet soils stunt its growth.

### **Propagation and Care**

The tree can be propagated through direct seeding. Three or four seeds are planted at depths of 3-4 cm, and at distances of 2-3 m.

**Leguminosae (Papilionoideae)**

*Sesbania bispinosa*

### **Family**

Leguminosae (Papilionoideae)

### **General Description and Distribution**

*Sesbania* is a spreading shrub-like plant that grows tall and straight in crowded stands. It may reach 4 meters in 5- 6 months. Because it grows quickly and produces nodules, it is possible to produce a firewood crop as well as enrich the soil for a rotational crop.

It is native to tropical and subtropical areas on the Indian subcontinent, but has been successfully propagated in Southeast Asia.

### **Use**

The tree is primarily used for firewood. Seeds produce a gum used in textiles, paper, and solutions. The wood can also be used to produce paper, fiber, green manure, and fodder.

### **Environmental Requirements**

The tree grows in the tropics and subtropics from sea level up to 1,200 m. It is resistant to drought but grows best in regions with 550-1,100 m of rainfall. The tree is suitable to adverse soil conditions, including saline and alkaline soils.

### **Propagation and Care**

Direct seeding is the quickest and best method of propagation. It grows so quickly it is used to control the spread of *Imperata cylindrica*.

*Sesbania grandiflora*

### **Family**

Leguminosae (Papilionoideae)

### **General Description and Distribution**

*Sesbania grandiflora* grows to a height of 10 m, with a trunk diameter of about 30 cm. It produces firewood, forage, pulp and paper, food, and green manure. It works well in agroforestry systems designed to control erosion and improve soil fertility.

The tree is native to many Asian countries and is normally seen growing along roadsides, and in vegetable gardens and rice fields.

### **Use**

The tree is primarily used for firewood. Plantation grown trees have reached 8 m in 3 years with an average diameter of 10 cm. Wood yields have been as high as 20-25 m cubed per hectare per year. The tree is commonly used for beautification programs along roadsides. The young leaves, pods, and flowers are used in curries and soups or steamed, fried, or boiled.

The tree is also used to control the spread of *Imperata cylindrica*

### **Environmental Requirements**

The tree grows in the tropics and subtropics from sea level up to 1,200 m. It is resistant to drought but grows best in regions with 550-1,100 m of rainfall. The tree is suitable to adverse soil conditions including saline and alkaline soils.

### **Propagation and Care**

Direct seeding is the quickest and best method of propagation. Once established it shades out weeds.

## **Malvaceae**

*Hibiscus tiliaceus*

### **Family**

Malvaceae

### **General Description and Distribution**

The hibiscus is an evergreen that can grow 12 m tall. It has a short trunk and a broad, rounded crown. In wetlands it grows close to the ground, forming a low and sprawling mound.

It is commonly found growing just inshore of mangroves on the coastal fringe and extending up estuaries and rivers. It can be found in many parts of Southeast Asia and the Pacific Islands.

### **Use**

Because the hibiscus is fast-growing it is principally used for firewood. When cut back, it quickly sprouts long stems. Because the wood is light, flexible, porous, easy to work, and durable in salt water, it is popular amongst fishermen. It is also used in constructing huts, tools, and fine furniture.

The bark of the wood is equally prized. It is often used for making rope and twine.

In several areas the tree is used to stabilize sand dunes and control erosion. It has an added effect of beautifying the surrounding landscape.

### **Environmental Requirements**

The species grows well in warm, humid climates. It ranges in elevation from sea level to 500 m. It demands an average annual rainfall of approximately 1,400 mm. It grows in almost all soil types, and is highly salt tolerant.

### **Propagation and Care**

The tree can be propagated from seeds or cuttings. In 2- 3 years the tree is large enough to shade out surrounding vegetation.

It is not susceptible to pests or diseases.

## **Meliaceae**

*Melia azedarach*

### **Common Name**

Chinaberry

### **Family**

Meliaceae

### **General Description and Distribution**

This is a medium sized deciduous tree, 6-30 m tall and 50-80 cm in diameter, which is popular as an ornamental and for fuelwood. It produces pale, purplish flowers, red berries, and dense, dark, green leaves. The tree is native to Asia

## **Use**

Chinaberry is planted for firewood, reforestation programs, and veneer. Because the wood is soft it is used in furniture and other soft wood products. It has insecticidal properties, and the leaves can be fed to goats. The seeds are often used in bead making.

The specific gravity is about 0.66 (calorific value 5,043-5,176 kcal per kg).

## **Environmental Requirements**

The species grows in climates where the mean annual temperatures are at least 18 degrees centigrade. It grows up to 2,000 m as well as in the lowlands. Rainfall can vary between 600-1,000 mm annually. In drier climates the tree does well along bodies of water.

The tree grows on a wide range of soils. Best growth is obtained on well-drained, deep, sandy loams.

## **Propagation and Care**

The tree can be propagated from seed or cuttings. Seedlings are normally transplanted after six months. To hasten germination, soak the seeds in water for several days.

The limbs are easily broken by strong winds, and the fruits are poisonous.

## **Myritaceae**

*Eucalyptus brassiana*

## **Family**

Myritaceae

## **General Description and Distribution**

This species of Eucalyptus is a hardy, fast growing tree adapted to the lowland tropics. It grows from 7 to 15 m high on infertile soils, and to more than 30 m high on fertile soils. Approximately half the trunk grows fairly straight. The other half is usually twisted and contorted, and splits into several branches.

Eucalyptus brassiana is found in lowland areas in Papua New Guinea. It is being tested in other tropical areas.

## **Use**

The wood is used for firewood and construction material. In experimental plots, it has grown as high as 7.6 m, with a diameter of 6.3 cm at 2.5 years of age.

## **Environmental Requirements**

The natural habitat of the species is tropical and humid to subhumid. The tree can withstand temperatures of at least 32 degrees centigrade, and grows up to 650 m above sea level. It can tolerate a dry season of 3 to 5 months; minimum annual rainfall is 1,000 mm. Infertile soils are not considered a problem for the species. It grows on rocky slopes, inundated flats and depressions.

## **Propagation and Care**

Seeds are first planted in a nursery, then transplanted after 6-10 weeks. For rapid growth the area must be free of weeds.

*Eucalyptus deglupta*

## **Family**

Myritaceae

### **General Description and Distribution**

*Eucalyptus deglupta* is known in the Philippines as bagras, and in Papua New Guinea as kamarere. It is one of the world's fastest growing trees and is known to be capable of colonizing land eroded by landslides and destroyed by volcanic activity. It is a large tree which normally grows from 35-60 m high, with diameters of 0.5-2 m. The trunk is typically straight.

The tree is found in the southern Philippines and Papua New Guinea. It has been introduced into other tropical areas.

### **Use**

The wood is normally too valuable to be used as firewood. However, because it grows so quickly it could be used fuel as well as timber. It has a specific gravity of 0.40-0.80. It can reach 44 m in height after 15 years, and under plantation conditions common yields are 2040 m<sup>3</sup> per ha per year.

The wood is also good for heavy construction, furniture, and flooring.

### **Environmental Requirements**

Temperature can vary between 32 degrees centigrade along coastal areas to 24 degrees centigrade in higher altitudes. *Eucalyptus deglupta* grows up to 1,800 m above sea level. Average annual rainfall is 2,500- 3,500 mm.

The tree prefers deep, moderately fertile, sandy loams.

### **Propagation and Care**

The tree is first established in a nursery, then transplanted. It normally flowers in 3-4 years. The area surrounding the tree must be kept free of weeds for at least the first six months.

Trees are attacked by termites, moths, ring bark borers, corded bug (Solomon Islands), ants, and stem and bark borers (Papua New Guinea and the Philippines).

The tree is sensitive to fire and drought.

*Eucalyptus pellita*

### **Family**

Myritaceae

### **General Description and Distribution**

*Eucalyptus pellita* is commonly known as red mahogany. It grows in humid and subtropical lowland regions. It is a medium to large tree, usually 20-25 m in height. It has a large straight trunk with a heavily branched crown. If planted along a rocky coastline it will resemble a shrub.

The tree occurs between the northeastern and southeastern tip of Australia.

### **Use**

The wood is suitable for charcoal and firewood. The density is 990 kg per m<sup>3</sup>, with a mean height of 13.7 m. The average diameter is 12.6 cm.

In addition to its use as a firewood, the wood can also be worked to produce fine furniture. The flowers are also suitable for honey bees.

### **Environmental Requirements**

Maximum temperature is 33 degrees centigrade. It grows up to 750 m above sea level. Average annual rainfall is 900-2,300 mm.

The tree grows mainly on gentle to moderate, well drained topography, yet will survive on well drained, steep slopes. The species prefers sandy soils.

### **Propagation and Care**

The tree can be direct seeded or transplanted. Weeds are not a problem as the plant is shade tolerant.

*Eucalyptus robusta*

### **Family**

Myritaceae

### **General Description and Distribution**

This is one of the most widely planted of the Eucalyptus trees. It attains heights of 25-30 m and diameters of 1-1.2 m. The trunk is straight and branch free for over the half the tree's height. The crown is typically dense. The tree is widely acknowledged for its ability to grow on adverse sites.

The tree grows from the equator to about latitude 35°.

### **Use**

The wood is used for firewood and charcoal in several Asian and Pacific countries. It has a specific gravity of 0.70-0.80.

The wood is also suitable for plywood, construction material, shelterbelts, and pulp.

### **Environmental Requirements**

In warm, humid climates, the tree will grow from sea level to 1,600 m. The amount of rainfall must be between 1,000 to 2,000 mm a year with a four month dry season.

It grows well in most soils. However, it grows poorly in droughty sands.

### **Propagation and Care**

The tree is usually grown from seed in containers. The seedlings should be transplanted early in the rainy season. Weeds must be cleared during the first six months of growth. The tree may be attacked by a bacterium and termites. The tops of the trees may break during strong winds.

*Eucalyptus tereticornis*

### **Common Name**

Red gum, blue gum, mountain gum

### **Family**

Myritaceae

### **General Description and Distribution**

This is one of the most widely planted of the Eucalyptus trees for firewood and timber purposes. It is a moderately large tree that attains a height of 30-45 m and a diameter of 1-2 m. The trunk is straight and the crown open. Small clusters of white flowers bloom every year, with heavy blooming every three to four years.

The tree grows in the savanna woodlands of Papua New Guinea, and has been introduced to many tropical countries in Asia. It is normally found in open forests or as scattered trees on alluvial flats and along stream banks.

### **Use**

The wood is hard, heavy, and strong with a specific gravity of 0.75 or higher. It produces first class firewood and good charcoal. Being immune to termites and dry rot, it is a durable timber used in construction. It is considered one of the best trees for fiber for paper pulp and rayon.

The tree is also widely used as intercrop with various crops for the first 12 months after it is planted. In Central and South America, the tree is used to reclaim sand dunes. In Asia, the species is used extensively in afforestation and reforestation programs.

The leaves produce oil, and the flowers are an important source of nectar and pollen for honeybee colonies.

### **Environmental Requirements**

The species occurs within a climatic range with mean annual temperatures from 17 to 38 degrees centigrade. The tree has been known to survive successive frosts. In warm, humid climates, the tree will grow from 600 to 1000 m. The tree can be planted in areas with a moderate to severe dry season. Optimum rainfall is 800 to 1,500 mm. It has survived in both extremes.

It grows best in deep, well drained, light textured soils that are neutral or slightly acid.

### **Propagation and Care**

The tree is usually grown from seed in containers. The seedlings are transplanted at 15-25 cm, which takes approximately 3-4 months in the nursery. Although the species can compete with weeds, it is recommended weeds be cleared until the canopy closes. Periodically work the soil between the rows for good yield.

*Eucalyptus urophylla*

### **Family**

Myritaceae

### **General Description and Distribution**

*Eucalyptus urophylla* grows to approximately 50 m in height with a diameter of up to 2 m.

It is common to Indonesia, but is showing promise in Southeast Asia and the Pacific Islands.

### **Use**

The wood is suitable for firewood. It yields 20-30 m<sup>3</sup> per hectare per year. The wood is also used in construction.

### **Environmental Requirements**

Temperature requirements vary between 18- 28 degrees centigrade. It is primarily a mountain species that grows best between 300 m -3,000 m. Rainfall can be as low as 1,300 mm, and as high as 2,500 mm. It grows best on deep, moist, free-draining, medium-to-heavy soils derived from noncalcareous rock.

### **Propagation and Care**

In several experiments the species was grown in plastic bags and transplanted to the field after 55 to 75 days.



The species is susceptible to termites and cutting insects.

*Melaleuca quinquenervia*

### **Common Name**

Broad-leaved tee tree, iaouli

### **Family**

Myritaceae

### **General Description and Distribution**

This is a fast growing tree that can tolerate wet soils. It grows at high planting densities, and quickly shades out competing vegetation. It has been grown up to 25 m tall, and if grown in dense stands will develop straight stems. It has a whitish, thick, and spongy bark, which splits and peels in layers, and becomes rough and shaggy. The leaves are aromatic, and have white flowers.

The tree grows in Papua New Guinea and New Caledonia, and has been propagated in other tropical countries.

### **Use**

Only the bark of the wood is used for firewood. The wood can be used for pilings, railway ties, mine braces, posts, fences, flooring, rafters, and after proper seasoning, ornamental woodwork. In addition to firewood, when ground, the bark can be used as mixture in potting soil. Stands have produced 7,000-20,000 stems per hectare. Forty year old trees have been measured at 50 cm in diameter and 18 m in height.

Since the tree blooms throughout the year, it produces abundant pollen and nectar. The honey is valued in the baking industry and by health food dealers. When crushed, the leaves, twigs, and seed capsules produce an oil which is mixed with the oil from *Melaleuca cajeputi* to produce a pharmaceutical.

### **Environmental Requirements**

The species grows in areas with mean annual temperatures ranging from 18 to 34 degrees centigrade. In Australia the tree occurs in low altitudes up to 500 m. In Hawaii, under wet conditions, it grows up to 1,400 m. Rainfall can vary between 1,000 mm to 5,000 mm.

The tree occurs on old and new alluvial soils, on shallow soils, and on infertile soils.

### **Propagation and Care**

The seeds must be in wet soil to germinate. Seedlings compete well with weeds and after the first six months will begin to shade out competing vegetation.

Caution is required in planting the species as it will quickly crowd out native vegetation and become a nuisance.

*Psidium guajava*

### **Family**

Myritaceae

### **General Description and Distribution**

*Psidium guajava* is commonly known as guava. It is a shrub or low-growing tree that can withstand repeated cuttings. It produces a small, green fruit that makes excellent jam and juice.

Guava is indigenous to the American tropics but can be found throughout Southeast Asia and the Pacific Islands.

### **Use**

The wood is both heavy and strong, and makes good firewood and charcoal. It has a specific gravity of 0.8, and caloric value of 4,792 kcal. When continually cut, the tree naturally regenerates itself.

Guava makes excellent jam, jelly, and juice. It has two to five times the vitamin C content of orange juice. Tea made from the leaves of the tree is considered medicinal. It is used to offset the effects of stomach pains associated with giardia and amoeba. The leaves are also used for dye and tanning.

The wood is also used in the construction of farm implements.

### **Environmental Requirements**

Guava trees grow in the tropics from sea level to 1,500 m. It requires approximately 1,000 mm of rain, and can withstand a dry season of 4-5 months.

Guava grows well in an acid and alkaline soils. Poor soil drainage is not a problem.

### **Propagation and Care**

The tree can be grown from seeds or cuttings. Seeds germinate in 3-5 weeks. Because the plant is exceptionally hardy it can compete with weeds and partial shade.

The fruit is susceptible to fruit flies, mealy bugs, scale insects, and thrips. Wilt may occur when grown in soil with a pH above 7.5. Bark canker, dieback, caterpillars, and mealy scale may kill branches.

*Syzygium cumini*

### **Family**

Myritaceae

### **General Description and Distribution**

Syzygium is a large, fast growing tree with shiny, green, leathery leaves. Mature trees are on the average 13 m with a trunk diameter of approximately 1 m.

The tree is native to the Philippines, and has been introduced to many other tropical and subtropical countries.

### **Use**

The tree is considered to be an excellent firewood. Its specific capacity is 0.77. Its calorific content is 4,800 kcal per kg. The wood is durable in water and resistant to termites. For this reason it is often used for farm tools, and in the construction of boats. The tree also produces a fruit which is eaten raw, or made into vinegar, jellies, or wine. In the Philippines the fruit is called duhat. When planted on the edge of animal yards the foliage provides shade and the fruit is readily devoured by the animals. Because of its wide canopy, syzygium is often used for shading. When planted in dense rows and periodically topped, it forms a strong windbreak.

### **Environmental Requirements**

The tree grows well in areas with rainfall between 1,500 mm to 10,000 mm. It can withstand flooding as well as drought. It is found growing up to 1,800 m, and in various types of soil.

### **Propagation and Care**

Direct seeding is the most common method of propagation, although syzygium is also easily transplanted from a nursery. If direct seeding the seeds should be sown during the onset of the rainy

season. Germination normally occurs after 2-3 weeks. Once established, the tree shades out weeds. Care should be taken to control the spread of its seeds, as it soon becomes a weed and shades out other favorable species.

## **Pinaceae**

*Pinus caribaea*

### **Family**

Pinaceae

### **General Description and Distribution**

*Pinus caribaea*, more commonly known as caribbean pine, is a large tree that can grow to 45 m in height and 135 cm in diameter. The tree is normally straight with regular branching. It has become one of the more important commercial trees in tropical areas below 1,000 m.

Plantations have been established in Southeast Asia.

### **Use**

The tree can be used as firewood. It has a specific gravity of 0.4-0.66, and a annual incremental yield of 21-40 m<sup>3</sup> per ha. In addition to firewood, the wood is used for general-purpose pulpwood, particle board, and fiber board. It is also for boat building, heavy construction, and furniture components.

### **Environmental Requirements**

It grows best in temperatures ranging from 22-28 degrees centigrade, with a maximum temperature of 37 degrees. The species grows best below 1,000 m.

Rainfall requirements vary between 1,000 mm and 1,800 mm. Plants have been observed growing in areas with less than 660 mm.

The species usually grows on loams or sandy loams that are well drained. The pH is between 5.0 and 5.5.

### **Propagation and Care**

Provide the correct mycorrhizae in the soil and soak seeds in water for 24 hours prior to planting in a seed bed. The tree does not compete well with tall grasses, so it is necessary to clear the immediate area for the first year.

The species is susceptible to soil-borne pathogens and fungi. Serious insect pests include beetles, pine aphids, leaf cutting ants, termites and moths.

## **Polygonaceae**

*Coccoloba uvifera*

### **Family**

Polygonaceae

### **General Description and Distribution**

Commonly known as seagrape, *Coccoloba* is a roundtopped, spreading, low -branched tree that grows up to 15 m high with thick smooth branches and a stout 1 m trunk. The leaves are large, thick, and almost circular. The flowers develop into a grapelike edible fruit. The tree is not as large when grown along the seacoast.

Coccoloba is native to the Caribbean but is successfully propagated in South America, Hawaii, and the Philippines.

### **Use**

The wood is used for firewood and charcoal. It is prized because it is easy to light and gives off an extremely hot, smokeless flame. It also grows quickly, is multi-stemmed, and branches profusely.

The tree is also used in furniture making, as an ornamental, and for fruit, honey, and bark.

### **Environmental Requirements**

The tree requires a tropical to subtropical climate full sun and low altitudes. In the Philippines it grows from sea level up to 500 m. It survives rainfall variations of 500 mm to 1,400 mm. It grows on pure sand, rocky coasts, limestone and diabase, and it is tolerant of salt.

### **Propagation and Care**

Although seeds germinate rapidly, the seagrape may not fruit for 6-8 years. Vegetative propagation is preferred for quicker growth, and to assure reproduction of female tree.

The young seedling is sensitive to shade and must be weeded on a regular basis.

### **Rhamnaceae**

*Maesopsis eminii*

### **Family**

Rhamnaceae

### **General Description and Distribution**

Maesopsis is a fast growing tree that is free of branches for 9-20 m, and has a wide, full crown. Its recommended use is for enrichment planting in the humid tropics.

Plantations have been established or natural forests managed in Southeast Asia and the Pacific Islands.

### **Use**

Because the wood is light (specific gravity 0.38-0.48) it is not an ideal firewood. It can be used for indoor construction, plywood, and pulpwood. In some areas the tree is used to shade coffee and cacao.

It also produces fruit which is eaten by animals.

### **Environmental Requirements**

The tree requires a mean annual temperature ranging from 22-27 degrees centigrade. It is normally found between 100 and 700 m above sea level. It has been observed in an African country at 1,200 m.

The species requires at least 1,200 mm of consistent rain. Soil should be moderately fertile, well-drained, light-to-medium-textured, with a neutral to acid pH.

### **Propagation and Care**

In many cases natural regeneration takes place as birds eat and distribute the seeds. The tree can be propagated by direct seeding or cuttings. If direct seeding, soak the seeds in water for 2-3 days.

During the early stages of growth, the tree cannot compete with Imperata grass. The young trees are susceptible to fungi. Fungus infestation may occur if the trees are planted on poorly drained, infertile soils.

### **Rhizophora, Avicennia, Bruguiera**

*Mangroves*

### **Botanic Names**

Rhizophora, Avicennia, Bruguiera

### **General Description and Distribution**

Mangroves are typically shrub like trees but can also range up 40 m tall and 1 m and more in diameter. They are normally found in saline mud flats in tropical and subtropical climates. Mangroves are unique in that they can survive waterlogging, poor soil aeration, salinity, high humidity, and strong winds. The wood is an excellent firewood, and also used by many cultures in jewelry making. Some southern Philippine tribes use the wood for medicinal purposes.

Mangroves are abundant around the Indian Ocean, Southeast Asia, the Pacific Islands, the southern United States, and Central and South America.

### **Use**

Mangrove is primarily used for firewood. It splits easily, is heavy, and burns over a long period of time. It also makes excellent charcoal. Specific gravity is 0.7 to over 1.0. Calorific content in most species is 4,000-4,300 kcal per kg.

Mangroves are also instrumental in protecting estuarine areas against the full effects of tropical storms. Further, the blanket of vegetation offers spawning grounds for many aquatic species upon which fishermen depend. Tannins from the wood are used to produce hard leather, and the resins are used for bonding plywood.

### **Environmental Requirements**

Mangroves only survive in tropical areas and are very sensitive to frost. They grow best where the average annual rainfall is over 1,000 mm.

They survive in saline, poorly drained soils, but grow best in areas with regular tidal movements. In order to control excessive salinity and thus promote healthy growth, regular flushing with seawater or freshwater should occur. Mangroves grow poorly when surrounded by levees.

### **Propagation and Care**

Because mangroves grow rapidly there is very little experience with actual propagation. Where plantations or test plots have been planted, direct seeding has been the most successful. No seed treatment is required, and except the leather fern, weeds are not a problem because of the harsh conditions in which the tree is found.

### **Urticaceae**

*Trema species*

### **Family**

Urticaceae

### **General Description and Distribution**

Trema species are shrubs or small trees with spreading crowns and evergreen leaves. They can reach heights of 10 m and diameters of 20 cm. The species is normally the first species to grow following the denudation of land.

Of the four Trema species, two have been successfully cultivated in the tropical islands of the Pacific: *Trema cannabina* and *Trema orientalis*.

### **Use**

Although the calorific value of the species is only 4,500 kcal per kg, the species is collected for firewood. Their best use is for the protection of denuded and disturbed areas. The species is also used as a shade tree for coffee, cacao and other crops.

### **Environmental Requirements**

The tree has been identified growing up to 2000 m. Rainfall requirements are species specific. *Trema orientalis* requires a moist, humid climate. *Trema politoria* a dry climate, and *Trema guineensis* grows well in humid and dry climates. The species has no particular soil requirements.

### **Propagation and Care**

Seeds need to be refrigerated at 2 degrees centigrade for 2- 3 months, or treated with gibberellic acid in order to break dormancy.

### **Verbenaceae**

*Gmelina arborea*

### **Family**

Verbenaceae

### **General Description and Distribution**

*Gmelina* is a medium to large deciduous tree which may reach heights of up to 30 m with a trunk diameter of 60 cm. It develops low wide branches, and a wide crown. It is a promising fuelwood that is easy to handle, grows quickly, and is adaptable to a wide range of soils.

The tree is native to most Southeast Asian countries and is being tested in other countries as well.

### **Use**

The wood is primarily used for firewood in many African nations. Its caloric value is 4,800 kcal per kg. Charcoal produced from the wood burns without smoke. It is reported some trees grow to 3 m in the first year and 20 m after 4.5 years. The wood can also be used as particle board, plywood core stock, sawtimber, packing, and furniture. The flowers can be used to produce a high quality honey.

### **Environmental Requirements**

*Gmelina* withstands up to 52 degree centigrade. It will grow up to 1,000 m. Required rainfall ranges between 750 mm to 4,500 mm annually. It is successfully propagated in the northern Philippines, which experiences a six month dry season.

The plant is adaptable and survives well on a wide range of soil types including acid soils, calcareous loams, and lateritic soils. It will not grow well in waterlogged soils, thin soils, leached acid soils, or hot sandy soils.

### **Propagation and Care**

The tree can be propagated from seed from cuttings, or by budding and grafting. A spacing of 2 \_ 2 m is recommended for fuelwood plantations. It is possible to integrate the tree with other crops during its early stages of growth. Following establishment nothing will grow under its dense canopy.

The tree is attacked by ants and defoliating insects. Bark and machete disease are severe in humid areas. Because the leaf of the tree is palatable to livestock, wood lots should not be established near grazing areas.

### **Tropical Fruit Trees**

*Anona muricata*

#### **Common Name**

Soursop

#### **General Description and Distribution**

Soursop is a small evergreen 7.5-9 m high, with a 10-30 cm long fruit weighing as much as 4.5-7 kg. The fruit is spiny, and the flesh is acid, aromatic and juicy. Many large, black seeds are embedded in the flesh.

The fruit is grown throughout the tropics.

#### **Use**

The fruit is used to make drinks, or to flavor ice cream or cold fruit bars. The tree grows quickly and may grow to 2 m in one year, with fruit in the second year. In some cases it may take three to four years before bearing. Yields have exceeded 3,500 kg/acre in the fourth year with yields increasing to 7,000 kg in the sixth year.

#### **Environmental Requirements**

The species grows in the lowland tropics, and prefers rich, deep, well drained loams.

#### **Propagation and Care**

The tree is usually propagated by seed, chosen from healthy well developed trees. Seeds are planted in seed boxes or beds containing a mixture of sand, soil, and compost. The seeds germinate in 15-20 days. If planting in boxes, transfer the seedlings to plastic bags when 15 cm tall. Transfer the seedlings to the field when 30 cm in height at the beginning of the rainy season. Space 3.6 \_ 4.5 m. In small gardens this can be reduced to 2.5 \_ 2.5 m.

*Annona squamosa*

#### **Common Name**

Sweetsop, sugar apple

#### **General Description and Distribution**

Sweetsop is a woody semi-deciduous shrub or small tree reaching 4.5-6 m in height.

#### **Use**

The fruit is used mainly as a desert fruit and contains 16-18 percent sugars. A purgative tea is made from the roots and a mildly laxative and tonic tea from the leaves. The crushed leaves and seeds are insecticidal.

It may take three or four years for the trees to bear fruit.

#### **Environmental Requirements**

A. squamosa grows at low to medium elevations in the tropics. It cannot stand frost or long cold periods, but withstands drought better than many fruit trees.

## **Propagation and Care**

The tree is usually propagated by seed in a bed or plastic bags. Germination occurs in 50-70 days. Scarification and soaking for three days hastens germination. Seedlings should be grafted after a year. When transplanting to the field, space the plants 4 \_ 6 m.

*Artocarpus altilis*

## **Common Name**

Breadfruit

## **General Description and Distribution**

Breadfruit is a large tree restricted to humid tropical regions. It is a food staple in many places, being rich in carbohydrates. It is a tall, straight, spreading tree, 12-18 m. Branches usually start low on the trunk. The leaves, which are concentrated at the ends of the branches, are very large, deeply lobed, leathery, and slightly hairy on the lower surface.

## **Use**

The fruit is used solely for food. It varies in size from 10-25 cm in diameter. In the seedless variety the central core is composed of edible pulp.

Seedlings come into bearing when they are eight to ten years old, but vegetatively propagated trees start to crop within five to six years. Individual species determine taste and the number of seeds.

## **Environmental Requirements**

A warm, humid climate is required, with temperatures of 16-38 degrees centigrade and a well distributed annual rainfall of 200-250 cm. The tree is intolerant of cold and of extreme conditions, such as those found at high elevations.

The best growth is in deep, moist soils with a high humus content and high fertility; good drainage is essential.

## **Propagation and Care**

The use of root cuttings has proved to be the most reliable method of propagating breadfruit. With this method plants ready for field planting can be obtained in 14 months.

Take cuttings at the end of the dry season and the beginning of the rainy season when energy is stored in the roots of the plant. Cuttings should not be more than 6 cm in diameter and 25 cm long. Place the cuttings in raised beds composed of sandy loam. Place diagonally at a distance of 12 \_ 25 cm. Keep the soil moist and, if possible, spray the cuttings two to three times a day. The cuttings are ready for potting after six or seven months or after they have made 20-25 cm of root growth. Wait an additional six to seven months before transplanting to the field.

*Artocarpus heterophyllus*

## **Common Name**

Jackfruit

## **General Description and Distribution**

Jackfruit is a fairly tall tree ranging from 9-23 m in height, with a straight trunk, branching near the base and forming a dense irregular crown. Large fruit are borne on short stalks on the main branches, but as the trees mature the fruits are produced from the stalks as well. Fruits are normally produced year round.



The tree is spread throughout Asia and the Pacific.

### **Use**

The fruit is mainly produced for human and animal consumption. The fruits, which are of immense size, contain between 100 and 500 large seeds surrounded by a yellow stringy pulp. The pulp is pulled away from the seeds and eaten like candy. It also makes an excellent meal when boiled. The tree generally begins to bear after four to eight years.

The wood is also highly prized for construction and furniture making.

### **Environmental Requirements**

Although the Jackfruit thrives in a moist, tropical climate, it is well adapted to a wide range of conditions. It is tolerant of lower temperatures, but is injured by frost. Young trees need protection from the sun. Plenty of moisture in the soil is essential, but the tree is intolerant of poorly drained soils. The best growth occurs in deep alluvial soils of open texture.

### **Propagation and Care**

The most common and simplest method of raising Jackfruit trees is from seed. Other methods proven successful are etiolation, air layering, patch budding and approach grafting. Even when propagated vegetatively the rootstocks are from seed.

Plant large, heavy seeds in beds or plastic bags immediately after extraction. Germination normally takes three to four weeks. Germination time can be reduced if seeds are soaked for 24 hours prior to planting. Plant the seeds flat or with the pointed end facing downward. If planting in beds space the seeds 40 \_ 40 cm. Transplant to pots or bags after six months. It is generally recommended to plant the trees in bags or directly in the field because of their long tap roots. The long tap root is easily injured and bare root seedlings do not transplant well. Pot before the plant reaches the six leaf stage.

The plant is relatively free from pests and diseases.

*Averrhoa carambola*

### **Common Name**

Carambola

### **General Description and Distribution**

Carambola is a fruit tree usually cultivated in tropical home gardens. It is an attractive small tree about 12-15 m in height and bears numerous branches. The bark is grey and smooth and the crown is open. The twigs are covered with short yellow hairs when young, but become leafy as the tree matures. The leaves are composed of three to five pairs of ovate leaflets, about 2-9 \_ 1-4 cm in size, and are pale and shiny. The fruit is about 13 cm in length, attractive in appearance, golden in color, waxy in skin texture and deeply ribbed.

The tree grows throughout the tropics.

### **Use**

Some of the fruits are eaten raw while the less sweet are stewed or made into jams or a beverage. Another the variety, the bilimbi, is more acid and can be used in making pickles and curries. The bilimbi is also used for medicinal purposes. When mixed with pepper it induces perspiration. It is a cure for itch when applied hot, and is also known to provide relief for coughs, mumps, rheumatism, pimples, rectal inflammation, thrush, beri-beri, biliousness. Carambola has no such medicinal virtues, but is exceedingly more pleasurable to eat.

The tree comes into bearing the fourth or fifth year after planting. The fruits mature 14-15 weeks after fruit set. From anthesis to maturity takes about 101-108 days. Since flowers are produced throughout the year, fruit in all stages of development are present on the tree at the same time.

## **Environmental Requirements**

The carambola is a tree of the tropical lowlands and coasts but will thrive sheltered in the hills up to 1,200 m. Mature trees can withstand mild frosts much better than young trees.

The species is also tolerant as regards soil type provided there is good drainage. The tree is suited to dry weather, it also performs in areas with well distributed rainfall.

## **Propagation and Care**

The seeds of the carambola are small and, after cleaning and drying, should be sown in pots or boxes under light shade and kept regularly watered.

After germination the seedlings should be transplanted to nursery beds or plastic bags and hardened off. Transplant to the field at a spacing of 6 \_ 6 m. Expect fruits in four to five years.

Vegetative propagation will reduce fruiting time to ten months. Bud grafting is probably the most successful method of propagation.

*Chrysophyllum cainito*

## **Common Name**

Star Apple

## **General Description and Distribution**

Star apple is a smooth skinned apple shaped fruit from 5-10 cm in diameter. It is handsome ornamental evergreen tree which reaches a height of 15 m under favorable conditions. The leaves are oval, shiny dark green above and silky, coppery gold beneath. Small purplish-white flowers are borne in clusters scattered along mature twigs and partly concealed by the foliage.

The tree grows throughout the tropics.

## **Use**

The fruit contains a white, sweet, edible pulp in which are embedded 10 glossy dark seeds loosely placed in cavities. It has a good flavor but is too bland for some tastes.

Trees planted from seed come into bearing after five to nine years. Yields have reported at 70 kg per tree.

## **Environmental Requirements**

The star apple is tropical in its requirements and thrives in humid atmospheres with relatively high temperatures throughout the year.

The species grows very successfully in rich, deep soils but also does well in light, sandy soils if sufficiently fertilized. The tree responds very favorably to potash.

## **Propagation and Care**

Most star apple trees are raised from seed. The seeds germinate readily if planted fresh. Sow in boxes or bags in light, sandy loam soil. Germination takes about six weeks. When seedlings have three to five leaves, transfer to beds. This normally takes an additional six to eight weeks.

Inarching has proven to be the best method of vegetative propagation.

*Durio zibethinus*

## **Common Name**

Durian

### **General Description and Distribution**

A traveller once wrote that the durian is of such an excellent taste that it surpasses in flavor all other fruits of the world. Others have observed its flavor as that of a rich butter-like custard highly flavored with almonds. It is credited as having aphrodisiac properties.

The durian is a tall evergreen tree which can reach a height of 40 m or more. The trunk has a brownish-gray bark, rough and flaky, with deep longitudinal splits. It has a diameter of 120 cm or more with fairly low branches and a full, round crown.

There are reportedly 27 species of durian. Some of the 27 are only used for wood. The original home of the durian is contested. Some believe to be from Borneo, others from Malaya. It has been successfully propagated in other Asian countries, especially the Philippines,

### **Use**

Several species of durian are specifically cultivated for their fruit. The main edible part of the fruit surrounds the seeds. The seeds can also be cooked and eaten. Unripe, the fruit is often cooked like vegetable.

The durian comes into bearing at about twelve years of age. Although the tree can self-pollinate, cross-pollination has been observed as the most successful means of propagation. Because the stigma is most receptive in late afternoon and during the evening, bats are often the agents of pollination.

The fruits take about six weeks to develop. One tree may bear between 50 and 80 fruits a year. A large fruit may weigh as much as 3 kg and can grow up to 30 cm long and 15 cm in diameter. It is pale green in color and covered in hard, sharp, coarse spines. Opening a durian to get at the fruit can be difficult. Because the fruit is heavy and spiny, caution is urged when walking under the trees. Falling fruit are extremely dangerous.

The wood is used in furniture making and home construction.

### **Environmental Requirements**

The tree can survive at low as well as upper elevations. Successful growth has been reported at 760 m, with the highest yields at sea level. The tree needs a high relative humidity throughout the year and, since it becomes a very large tree when fully grown, the soil needs to be deep and fertile. Loams and alluvial soils, well drained but moisture retaining, are desirable. A tree of the forest, the durian tree grows better under shade when young.

### **Propagation and Care**

The durian is readily raised from seed. Since the seeds have a short viability period they should be washed, dried and planted as soon as possible. If the seeds are kept more than a week poor germination results. Plant the seeds in beds, spaced 30 cm apart and not over-watered. The seeds will germinate in three days. At the four-leaf stage some three to four weeks after sowing, transplant the seedlings to a wider spacing in the bed, or transfer to plastic bags filled with a compost mixture. Transplant hardened seedlings to the field at the onset of rainy season at a spacing of about 15 \_ 15 m.

The most practiced method of vegetative propagation is bud grafting although cuttings hold promise in highly controlled nursery conditions.

*Garcinia mangostana*

### **Common Name**

Mangosteen

## **General Description and Distribution**

The mangosteen is considered to be one of the best tropical fruits in flavor and aroma. Its taste suggests a cross between the pineapple, apricot, and orange. The flesh of the fruit melts in the mouth like ice cream.

The mature tree is approximately 10-25 m high. It has greenish white flowers that produce a dark purple berry about 4-7 cm in diameter. The tree seldom begins to fruit until it is six to eight years old and may not bear until the 15th to 20th years if grown under sub-optimal conditions. Mangosteen is grown widely throughout tropical Asia.

## **Use**

Over 400 species of mangosteen have been identified. Approximately 40 of the species are edible. Six are commonly grown for fruit. The fruits are used as flavoring substitutes, fish preservatives, syrups and jams, sources of acid for coagulating rubber, latex, tannins, and medicinal preparations. The food can also be canned. The seeds produce oil and butter.

## **Environmental Requirements**

The tree is naturally distributed in the zone between 10°N and 10°S. Temperatures below 5 and above 38 degrees centigrade are lethal. Temperatures less than 20°C may retard growth. Annual rainfall should be above 1,270 mm. The ideal temperature range is between 25 and 35 degrees centigrade with a relative humidity of over 80 percent. It has been grown up to 1,067 m.

## **Propagation and Care**

Mist propagation has proven to be the most effective means of hastening fruit bearing in mangosteen trees. If mist propagation is out of the question, it is possible to grow mangosteen from seeds. Choose seeds from the second crop produced by the parent tree. The seeds should be large and disease and damage free. If necessary, store the pulp-free seeds in peat moss and tightly sealed containers for no longer than four to five weeks. A higher rate of germination will be attained if the seeds are sown within five days of removal from the fruit. Average duration for germination can range from 10 to 54 days.

Plant the seeds in containers or directly in a seedbed. Seedlings are transplanted when they have developed four leaves. Since the root system of the mangosteen is fragile, slow-growing and easily disturbed, great care is required when transplanting. The tree is relatively free of diseases and pests. Protect the tree from high winds during the first two years of growth.

Trees are planted at a distance of approximately 10 \_ 10 m. Compost and/or well rotted manure should be added at 80-100 kg per hole. Add a 2.5 cm of mulch around the base of the plant at the end of the rainy season in order to help retain soil moisture and supply nitrogen.

*Lansium domesticum*

## **Common Name**

Langsat, lanzon, lanzone, lansone

## **General Description and Distribution**

The langsat is a medium sized tree, about 15-20 m in height. The tree bears both seeded and seedless fruit that are round or oval, 2.5 cm i diameter and 4 cm long, with a dull straw or brownish-yellow leathery rind which exudes a white latex when broken. The inside ia a white translucent flesh which separates into five distinct segments, It is very juicy and not extremely sweet which is characteristic of many tropical fruits.

Langsat is commonly found along roadsides and in gardens throughout Southeast Asia.

## **Use**

Only the fruit of the tree is commonly harvested.

### **Environmental Requirements**

The tree is usually planted below 600 m. Exposed sites should be avoided as strong winds can cause damage, especially when the trees have flowers and fruit. The tree does not require large amounts of nutrients or water, although it prefers a good loamy well drained soil.

### **Propagation and Care**

Seed propagation is the usual method of reproduction. Wash the seeds with water to remove any flesh which could ferment or mold, Air dry the seeds and plant as soon as possible after removal from the fruit, Plant the seeds in pots or bags or in a seedbed, If planting in a seedbed, space the seeds close together and 1 cm deep, Germination normally takes one to three weeks. When the seedlings are 15 cm tall and have at least two pairs of leaves they are thinned to 40-50 cm apart. Transplant to the field when the seedlings are 1,5 to 2,5 years old. Growth is slow and seedlings do not come into bearing until 12 to 20 years from time of planting, Vegetative methods or propagation include budding or grafting, layering or marcotting, or cuttings,

Transplant in the field at a distance of 7 \_ 7 m Do not plant deeper in the field than in the nursery. Ring weed around the base of the plants Plant avocado and breadfruit around the perimeter of the langsat to provide shade, food, and added income.

A root disease has been observed on young and old trees The disease is characterized in the field on aerial parts by leaf yellowing and wilting, followed by defoliation Below ground, the roots rot, become brownish black in parts or may decay completely. A wet, white fungal mycelium is found penetrating the wood and in the tissues of the decaying roots.

*Malpighia glabra*

### **Common Name**

Barbados cherry

### **General Description and Distribution**

The barbados cherry is a low-branching, spreading shrub rather than a tree, which under favorable conditions reaches a height of three to five meters. It has become popular since 1945 because of the high Vitamin C content of the fruit which is 20 times the amount found in orange juice The recommended daily requirement of Vitamin C can be met by eating three of the fruits.

Although the fruit is native to South America and southern Texas, it is also propagated in Southeast Asia and the Pacific Islands

### **Use**

Only the fruit of the shrub is harvested

### **Environmental Requirements**

The cherry will tolerate a wide range of climatic conditions, so long as it is not subject to long periods of cool weather The shrub is relatively drought resistant, but requires adequate moisture during periods of fruit development An annual rainfall of 1,780 mm has proven adequate for healthy growth

Shrubs have been grown successfully on various soils ranging from acid sands to heavy clays, provided they are not subject to waterlogging for more than a few days. The shrub is sensitive to deficiencies of nitrogen, potassium, calcium, and trace elements.

### **Propagation and Care**

Barbados cherries can be easily raised from seed, but it is important to get specially selected seeds in order to protect against undesirable characteristics.

Clean the seeds of flesh, dry and sow in beds at a distance of 30 \_ 30 cm between rows and 5 cm within rows. Cover the seed to depth of 6 mm. Shade the seeds and water regularly. When the seedlings are 7.5 cm tall transplant to containers or replant 30 cm apart within the row and 60 cm between the rows. Transplant to their permanent sites between six and twelve months old at the beginning of the rainy season.

Cuttings have proven to be the best method of vegetative propagation. The cuttings should be exposed to a high moisture regime such as that provided by continuous or intermittent mist.

*Mangifera indica*

### **Common Name**

Mango

### **General Description and Distribution**

The mango is one of the most important fruit crops of the tropics and the subtropics. It is known that Alexander the Great had mango orchards in the Indus Valley as early as 327 B.C. It has been in cultivation in India for well over 4,000 years. Because of the wide variety of species in Southeast Asia it has been speculated the mango originated in that part of the world.

The mango is an evergreen; it is one of the largest fruit trees and, when planted singly, normally has a spreading form. The tree frequently grows to height of 21 meters. In areas with no frost and low wind velocities, several hundred year old trees have recorded. The leaves are of leathery texture and vary in length from 2.5 to 10 cm. The flower has five small, green, hairy sepals and five small spreading petals. The fruit is a large drupe. The size of the fruit depends on the variety. Some are as small as plum; others may weigh as much as four to seven pounds. The shape varies from ovate, ovate oblong, round, oval to oblong. The skin is smooth, somewhat thicker than that of a peach, commonly yellow or greenish yellow in color. Some varieties assume a deep scarlet color. In tropical countries the mango seldom ceases growth and it is possible to propagate it vegetatively the year round.

The mango is grown extensively throughout Southeast Asia and the Pacific.

### **Use**

The tree is primarily used for fruit production. The fruit can be eaten ripe, unripe, made into a variety of dishes, and processed into a juice concentrate.

### **Environmental Requirements**

The mango thrives under a variety of climatic conditions but its profitable cultivation is limited by temperature and precipitation. It can endure a minimum temperature as low as 0 degrees centigrade and as high as 46-48 degrees centigrade. It is reported its growth is minimal at 4-10 degrees centigrade, and maximal around 42-43 degrees centigrade.

The mango grows in areas with scanty rainfall and also in very wet regions. The total amount of rainfall during a year seems to be of less significance than the season in which it falls. Eight-hundred and ninety to one-thousand and sixteen millimeters of well distributed rainfall is sufficient for the successful cultivation of mango. Excessive amounts of rainfall during flowering may inhibit pollination.

Mango trees in the tropics grow from sea level up to 1,220 m. Most large scale operations are located below 610 m. Altitude has a pronounced effect on the time of flowering. For every 120 m increase in height from sea level, the time of flowering is retarded by four days.

Mango trees flourish on a wide range of soils. However, they prefer a deep rich fertile soil because of the long tap root. Excessively sandy soils weaken the tree and lower the quality, size and quantity of fruit produced. The soil should be well drained and without a hardpan. A mango tree can withstand

periodic flooding, but orchards on poorly drained soils are generally unthrifty and less productive. Soils with fluctuating water tables are adverse for good root growth. For the development of a strong root system, the water table should not be higher than 2.5m from the surface. On deep, fertile and well drained soils, rootstock seedlings grow faster and become available for grafting operations much sooner.

### **Propagation and Care**

The mango can be propagated with ease by seed or with several vegetative methods of propagation. When developing projects it is recommended to propagate by vegetative means, as this will ensure uniformity in plant height and fruit characteristics. An enterprising project may involve growing seedlings to be sold as rootstock. This helps to eliminate variations in the performance of grafted plants in the orchards caused by genetic differences in the rootstocks.

Seeds should be obtained from fully ripe fruit. They gatherer should harvest seeds from one source in order to ensure uniformity. If conditions prohibit fruit collection from one source, collect from different sources including discarded fruits at markets. The size and the weight of the seed influence the percentage (%) germination. Only large, fully developed and plump seeds should be used. Light, diseased and malformed seed should be discarded.

Mango seeds lose their viability in a short time. It is always better to collect them from a nearby source and sow them within one week of extraction. The maximum period for which a mango seed will remain viable is said to be 100 days. It is necessary to store seeds placed in charcoal powder. The viability of a seed can be tested by putting them in a pail of water. Seeds which sink to the bottom have a higher germination percentage than those which float.

Seeds can be sown in different types and sizes of pots, plastic bags, or nursery beds. The containers or beds should have a fine mixture of sand, compost, and soil. Containers are generally 30 cm deep with drainage holes. Beds are usually 9 \_ 1.5 m, and about 15 cm in height. If possible, prevent the long taproot from penetrating the subsoil by placing a layer of concrete or plastic under the bed. Rows should be 30 cm apart. Distance between seeds is 15 cm. Place the seeds in the soil no deeper than five cm with the convex side up. Protect the containers and beds against the sun, wind, and rain. Water the beds regularly.

It is possible to propagate the seedlings by grafting, budding, cutting, and layering.

*Nephelium Lappaceum*

### **Common Name**

Rambutan

### **General Description and Distribution**

Rambutan is considered one of the most delectable fruits of the Tropics. The fruits hang in loose clusters of about a dozen. They are oval in shape, 3-5 cm long and 2.5-3 cm wide. They have a highly distinctive appearance, due to the yellowish-red, soft spiny outgrowths which cover the pericarp. The main edible part of the fruit is the aril which is white and juicy, with a subtle sweet to acid flavor. The aril encloses a nut like kernel which can also be eaten when cooked. The fruit is claimed to have moderately high Vitamin C content and the seed has a high oil content.

The tree is medium-sized, seldom attaining a height of more than 12 to 15 m, and a spread of about 6 m. The leaves are compound with five to seven short leaflets about 10 cm long.

Rambutan is mainly found in Malaysia and Java. It is also grown in many parts of the Philippines.

### **Use**

Only the fruit of the tree is harvested and is sold fresh. Like the litchi, rambutan can also be canned.

### **Environmental Requirements**

Rambutan is known to thrive up to an altitude of 300m. It thrives in moist, hot climates with well distributed rainfall. It is tolerant of a variety of soil types, but a deep, well-drained loam is preferred.

### **Propagation and Care**

Rambutan can be raised from seed, although it is not the preferred method. Trees raised from seed bear fruit after about six years, but vegetatively propagated plants may bear after two years.

When direct seeding it is essential that the seed is not more than two days old from the time it was removed from the fruit. Transplant the seedlings at about six months. Treat the seeding carefully as the roots are very sensitive.

If propagating by vegetative means raise rootstocks in beds or in plastic bags. When six to eight months old the seedlings are ready for budding or grafting. The total time from budding to the production of a plant large enough for planting out is about four to five months. Grafted plants are ready for cutting after approximately 40-60 days.

Marcotting is also a popular method of propagation. Select a branch that is 12-18 months old. Roots should appear after 6-12 weeks and after enough have been produced, cut the marcotts from the tree and place in pots in the shade. Water carefully until well established.

The main pests of rambutan are flying foxes and fruit bats. This is especially true at night when these frugivorous animals prey. It is necessary to cover the fruit or stand guard.

High winds can shed fruits prematurely as well as damage limbs. If mango is grown on a large scale in high wind area, it is beneficial to plant shelterbelts.

Mango trees in the tropics grow from sea level up to 1,220 m. Most large scale operations are located below 610 m. Altitude has a pronounced effect on the time of flowering. For every 120 m increase in height from sea level, the time of flowering is retarded by four days.

### **Appendix D. Composting**

Composting is a process which speeds up the breakdown of organic refuse in the soil, releasing nutrients for use by plants. Composting is necessary to improve poor soil in nurseries, gardens and planting sites.

The best composting method is the 30 day hot composting method. This system uses high temperatures (up to 170 degrees F) and frequent turnings to achieve a fast usable compost in one month. Advantages to this method include:

1. High temperatures kill weed seeds, disease and insect eggs;
2. Quickness of process provides plenty of compost

The following conditions must be met for suitable composting:

Carbon: Nitrogen (C: N) Ratio: The amount of carbon (C) materials, from dried plant material in ratio to the amount of nitrogen (N), from green, fresh plant materials

The C: N ratio should be 1:12 (1 part C to 12 parts N)

Sources of Carbon (brown dried plant material):

Dried leaves, straw, grass, weeds

Saw dust  
Wood shavings

Sources of Nitrogen (green plant materials):

Fresh grass and weed clippings



Fresh leaves from trees  
Animal manure  
Coffee grounds and kitchen refuse

The C: N ratio is important to maintain. Too much nitrogen will mean nitrogen lost to the air in the form of ammonia. Too much carbon will prevent the pile from reaching high temperatures, slowing down the process.

Other considerations for the pile include air and water. The microbes breaking down the material must have both to carry out decomposition. Avoid mounding the pile higher than 1.5 m, or air will not penetrate the entire pile. Provide enough water for the pile to be moist, but not so much that water oozes from the composting material if tightly squeezed. Excess water will kill the microbes by drowning; too little dries them out.

To begin, construct a frame of discarded wood or other materials 6 to 9 meters square. The frame should be low enough so the manager can easily turn the pile. Start the compost by piling a 13 cm layer of leaves, grass or discarded brush in the bottom of the frame. This provides drainage of excess water. Follow with 5 cm of grass clippings to promote the flow of air through the pile. Too much weight tends to pack the material and impede the flow of air thus, slowing the decomposition of the material. Now add topsoil and organic manure to introduce soil microbes. Microbial action is necessary to break the material into a usable form. In each layer mix in a little dried materials for carbon. Add kitchen scraps and water lightly if needed. Repeat the above steps until the pile is 1-1.5 m high. Cover the pile with black plastic or other heat-absorbing material.

Do not be afraid to add a host of other organic material to the pile. The pulp hulled from coffee beans is an excellent additive. Most mills have no further use for it and simply discard it. Rice and corn hulls are another additive. Scout the area and locate discarded organics that can be easily turned into a usable compost. One word of caution. Because the compost will form the base of the planting medium, do not include material that is diseased. Although the temperature of the pile should be high enough to kill pathogens, it is better to err on the safe side by excluding suspect material.

Obtain a soil temperature thermometer and monitor the piles' temperature. If a thermometer is unavailable check the temperature with your hand. A good pile will follow the following schedule:

Day	1:	110	degrees	F
	3:	125	degrees	F

If the pile doesn't heat up to 125 degrees F by the third day, break it up and start over.

After day 4 or 5 the temperature will start to drop. When this happens it is time to turn the pile over. Continue to turn the pile every four or five days. In order to maintain high temperatures, it is essential to keep the material moist at all times. Add water as needed. After about 30 days the material will have broken down into a usable compost.

Turning the pile involves mixing the material. For the first turning, use a pitchfork or shovel. Replace the outer material with the material on the bottom of the pile. This exposes the less decomposed material to higher temperatures. Break up any large chunks before turning them.

Another method uses three separate composting bins aligned in a row. Fill the bin farthest to the left with the material to be composted. When that material is ready to be turned, move it into the adjacent bin. Fill the first bin with fresh material. When the material is ready to be turned a second time, turn it into the last bin. Simultaneously turn the material from the first bin into the second bin, and place fresh material in the first bin. Continue to repeat the process. This method provides a continuous supply of compost for the nursery or planting area.

Compost is invaluable in the operation of a nursery, and is quite useful at the planting site. Consider teaching local farmers to make their own compost and assist them in their development.

## **Appendix E. Locating and Marking Contours**

An easy method of marking out the contours is to use an A-frame and plumb-bob device (See Illus. 6-1). To build the device the following items are needed:

- two poles of equal length, 1.5-2m long
- one pole 1m long
- nails, screws, or string to attach poles
- a piece of rock or heavy metal, globular in shape, about 5 cm in diameter for a plumb bob
- a 2 m piece of string to hold the plumb bob.

To build and prepare the A- Frame:

1. Lay all three pieces of wood on the ground and attach them together to form an "A" as in Illus. 6-1.
2. Attach the plumb bob securely to one end of the string. Attach the other end of the string to the top of the A-frame. Make sure that the string is tied long enough so that the plumb bob hangs below the cross piece, and short enough so that it will swing freely when the A-frame is standing.
3. Stand the frame up on level ground. Mark where each foot is placed.
4. Let the plumb bob swing and come to rest. Mark the crosspiece where the plumb bob string crosses it.
5. Reverse the position of the legs. Let the plumb bob come to rest and mark where the string touches or crosses the crosspiece.
6. Make a mark exactly between the two marks on the crosspiece. This will be the mark used to determine if the A-frame is level.

To use the A-frame to mark contours, the A-frame is "walked" along the side of the hill in the following manner:

1. Start at the top of the hill and mark the first line with a stake. Place one foot of the A-frame at the stake.
2. Slowly rotate the other foot up and down the slope until the plumb bob comes to rest with its string crossing the crosspiece at the middle mark. This takes patience, a bit of trial and error, and waiting for the plumb bob to come to rest. Exactness is not critical.
3. When the string comes to rest crossing the middle mark, the two feet of the A-frame are considered level, or on the contour. Mark the position of the second foot with a stake.
4. Walk the first foot horizontally across the slope by rotating it on the second foot. Repeat the leveling procedure (2 and 3) by rotating the first foot, and mark the level spot with a stake. Continue this procedure across the side of the hill until the edge of the planting area.

If a long carpenter's level is available, it can be placed on the crosspiece of the A-frame and used to find the level spot. This will be easier and faster to use than a plumb bob.

After a while a line of stakes will proceed across the hill at the same level, marking the contour (See Illus. 6-2). Move up or down the slope to finish marking the contours of the entire hill.

## **Appendix F. Health and Safety**

A community forester will be exposed to various hazards while working in the field. Caution must be exercised to try to avoid them, but the forester must also be prepared to act in case of accident or emergency. This chapter covers some of the more common dangers associated with forestry work: fire, risks associated with activities such as thinning and harvesting, heat and sun exposure, travel, poisonous plants and animals, coral rock, and pesticides.

### **Fire**

Firefighting and control was discussed extensively in Chapter 7. The major fire-related dangers are burns, being surrounded by fire, becoming confused in a fire, and smoke inhalation.

### **Burns**

Burn treatment is a topic best left to a first-aid manual. (See "Where There Is No Doctor," available from ICE.) To avoid burns, keep a safe distance from large and/or fast-burning fires. When fighting fires, always wear protective clothing such as thick gloves, heavy clothes and boots, a hat, goggles, and a face mask. Always carry water to douse sparks on clothing, skin, and hair, and to provide initial relief from third-degree burns.

### **Becoming Happed by Fire**

Being surrounded by a large fire can lead to serious burns or death. Always be aware of the position of the edge of the fire, the fire's general shape and direction, and any changes in wind direction and speed. Keep other firefighters informed of whatever information is available on the fire's condition.

### **Confusion in a Fire**

Firefighters who are separated from crews because of thick smoke, exhaustion, or darkness may quickly become confused, and can find themselves in dangerous situations. Make sure each firefighter is a part of a group of four or more and that the groups stay together at all times. Train firefighters to pay attention to their position at all times, and to be wary of being surrounded by smoke or exhausting themselves.

### **Smoke Inhalation**

Smoke inhalation can cause death through suffocation and internal burning. If surrounded by smoke, wet a handkerchief or cloth and place it over mouth and nose to cool and moisten incoming air as much as possible. Get out of the smoke cloud as quickly as possible. Take all necessary precautions to avoid becoming exposed to smoke. (For additional information on fire safety see "Fireman's Handbook," United States Department of Agriculture, Forest Service, Fire Protection and Staff Unit, 370 Reed Road, Broomall, Pennsylvania 19008 USA.)

### **Equipment and Tools - Safety Considerations**

The major risks associated with forestry activities include injuries from tools and heavy equipment and those that occur during felling activities.

### **Tools**

Tools must be kept sharp to function properly. Sharp tools can be a hazard, however, if used improperly. Learn and practice proper techniques for tool use before taking tools into the field. Train all workers in proper procedures, Exercise caution when carrying sharp tools on hilly or rugged land; falling on a sharp instrument may result in impalement. Draft animals can also be dangerous in field conditions. Ask a villager to teach you how to properly handle and care for the typical work animal. Begin slowly and work up to more difficult conditions. If using a draft animal on a steep slope, stay upslope of the animal.

### **Heavy Equipment**

Stay clear of heavy equipment when it is operating. Make sure only trained, qualified operators operate equipment. Heavy equipment has tremendous leverage and power and can inflict crippling injuries on workers.

### **Felling Activities**

All workers not involved in felling activities should stay clear of operations. When felling a tree, always be aware of the direction of the fall and the escape routes from under the tree. Do not work in a crowded, enclosed position from which rapid escape is difficult. When sizing up a tree to determine

the desired direction of fall, also consider which direction the tree might fall if something goes wrong, and plan accordingly,

### **Dangers from Sun and Heat**

The sun is more intense in tropical than in temperate zones. People working outdoors for long periods of time should protect themselves from overexposure to the sun. The hazards from overexposure include sunburn and the risk of skin cancer, heat cramps, heat exhaustion, and heat stroke.

### **Sunburn and Skin Cancer**

Sunburn is caused by excessive exposure of the skin to the ultraviolet rays of the sun. Light-skinned and fair-colored people are more sensitive to the sun's rays and should take extra precautions to avoid burning. Frequent overexposure to the sun has been shown to speed the aging of skin and can lead to skin cancer and other complications. To prevent sunburn and reduce the risk of skin cancer, avoid or minimize exposure to the sun between the hours of 10:00 am and 2:00 pm, when the sun is the most intense. Use a sunscreen containing **PABA** (para-aminobenzoic acid) whenever you will be exposed to the sun. Fair people should consider complete sunblocks such as zinc oxide on sensitive areas. A shade hat will also reduce sun exposure on the face. Long-sleeved cotton shirts and trousers or long skirts should be worn to protect other parts of the body.

### **Heat Cramps**

Heat cramps occur when the salt levels in the body are lowered due to sweating. Heat cramps are an indication of approaching heat exhaustion. To prevent heat cramps, avoid working on hot, humid days when possible. Drink adequate amounts of water and maintain salt levels in the body by eating some salty foods.

### **Heat Exhaustion**

Heat exhaustion is a response to heat characterized by fatigue, weakness, and eventual collapse. It is caused by inadequate intake of water to compensate for loss of fluids through sweating. Treatment includes administering sips of salt water, releasing or removing clothing, raising the feet, and cooling the body with wet cloths and fanning. After an attack of heat exhaustion, the victim should avoid exposure to hot temperatures for several days.

### **Heat Stroke**

Heat stroke is a response to heat characterized by extremely high body temperature and disturbance of the sweating mechanism (ARC). Heat stroke is an immediate, life-threatening problem. Symptoms are as follows:

- Body temperature is 106 degrees F or higher;
- Skin is hot, red, and dry (sweating mechanism has failed);
- Pulse is rapid and strong; and
- Victim may be unconscious.

Treatment involves cooling the body immediately, rubbing the whole body with cool wet towels or sponges soaked with alcohol, and administering ice packs or a cold bath (without ice). Avoid cooling the victim too much. Fans and air conditioners can be used to reduce temperature, if available. Monitor temperature after cooling. If the victim's temperature rises again, restart cooling procedures immediately.

### **Travel**

All forms of travel have associated risks. Since workers involved in community forestry who work on islands may be required to travel by boat or motorcycle, it is worthwhile to know hazards associated with these forms of travel and the precautions that can be taken to avoid injuries.

### **Boats**

Take care to load any small, open boat so that it is well balanced. Do not overload the boat with supplies or people. Be aware of currents, tides, and other strong water movements that will affect the navigation of the boat. Consult navigation charts for location and depth of reefs and other underwater obstructions, and give them as much clearance as possible. Keep an eye on the weather at all times to prevent being caught in a storm. Avoid going out into open water during a storm, where waves will be much higher than in protected areas. If caught, cover all hatches and as much of the boat as possible to prevent swamping. If the boat turns over or is swamped, **stay with it as long as possible**.

### **Motorcycles**

When riding motorcycles, a helmet is a must. Peace Corps Volunteers found riding motorcycles without helmets are sent home. A visor or goggles will keep bugs, dirt, and dust out of the eyes and allow clear vision. Other necessary apparel includes shoes or boots and sturdy clothing. Be aware of road hazards such as potholes, drainage trenches, slippery areas, and bridges, rocks, and other traffic. Carry tools in case of breakdown and know basic repair procedures.

### **Dangerous Plants and Animals**

The flora and fauna of islands can also present dangers to the unwary and ignorant. Never eat any plants that cannot be adequately identified. Local people are probably aware of hazardous and poisonous plants and should be consulted. If a reaction from eating a plant occurs, seek medical attention immediately.

Poisonous snakes are rare, but they may be encountered in the field. Stay as far away from any poisonous snakes as possible. Learn to identify local snakes and their habitats, and be on the lookout for them when in the field. If a poisonous snake species is abundant in an area, consider having antidote (if available) on hand for any mishaps. Obtain a list of hospitals in the area that have antidote. Learn from qualified medical personnel how to administer it.

Other dangerous wild animals, such as boars, should be avoided as much as possible. Most are wary of human presence and will try to escape to avoid detection. Many wild animals are dangerous only if cornered or startled.

Also be aware of animal traps set by villagers. If living in the jungle, be cautious when walking on wild animal trails. Most traps are set on these trails. Among other devices, traps include nasty mechanisms that explode when stepped on or bitten.

### **Coral Rock**

On many Pacific islands, the major rock form is coral limestone deposits. These rocks are very sharp, as the fossil coral and shells are exposed on the outside of the rock. Be careful when handling or walking among these rocks, as they can inflict serious cuts that can become infected. If cut, treat the wound immediately.

### **Pesticide Safety**

Pests that affect nursery and agroforestry sites can be classified into five main groups: insects, snails and slugs, pest animals, plant diseases (fungus, bacteria, etc.), and weeds.

Using a pesticide is only one of a number of ways to control pests. It should be considered only when the pest is causing more damage than the project managers can accept. If application of chemicals is necessary for control of insects, diseases, and other pests, care should be taken and procedures followed to avoid personal harm and damage to plants and/or soils.

The improper application of chemicals can result in serious bodily harm as well as environmental damage. All pesticides are toxic to some degree. Some pesticides are nearly as toxic if absorbed through the skin as if ingested. They are categorized by their **LD50 rating**, which refers to the "lethal dose," or amount of pesticide needed to kill 50% of laboratory test animals. The rating is expressed in terms of milligrams of pesticide per kilogram of body weight. For example, if the LD50 of a poison is 150, then 150 mg of the poison should kill one of every two rodents that weigh one kg each. The values are useful as measures of the relative toxicities of pesticides to humans.

The LD50 rating gives no indication of the cumulative effect of repeated or long-term exposure, however, some pesticides, particularly those which affect the central nervous system (including the organophosphate Parathion), may have cumulative effects

## **Pesticides and the Environment**

**Persistence and Accumulation.** Different pesticides react differently in the environment. Some break down quickly; that is, they are effective for only a short time before they are chemically transformed into harmless products. Others break down more slowly and may stay in a potent form for a long time. These are called persistent pesticides.

Pesticides become problematic when they affect sites or systems other than their intended targets. This happens when they do any of the following:

- Drift out of the target area in the form of dust or mist, carried by wind or with eroding soil;
- Leach through the soil into the groundwater;
- Are carried out as crop or animal residues; or
- Are improperly applied.

## **Safety Guidelines**

The proper use of safety equipment and protective clothing is essential. Persons using pesticides should be thoroughly protected from exposure to skin or open wounds, inhalation of fumes, and ingestion of pesticides in any form. A properly labelled pesticide container should indicate the kind of protective measures the user should take.

**Protective Clothing.** In general, any person using pesticide should wear clothing that completely covers the body: a long-sleeved shirt, long trousers or a coverall garment, gloves, hat, boots, and a face shield or goggles. Clothing should be made of closely woven fabric so that toxic materials cannot penetrate through to your skin. When handling pesticide concentrates or very toxic materials, wear a liquid-proof overcoat or apron. Trousers should be worn outside of boots to keep pesticides from seeping in.

**Gloves** should be long enough to protect your wrists and should be worn inside the sleeves to keep seepage out. They should be made of nonpermeable material such as plastic or neoprene.

Clothing should be cared for properly. If clothing gets wet with spray, change it as soon as possible. If clothing becomes saturated with pesticide concentrate or highly toxic chemicals, destroy it. Never wash or store pesticide-contaminated clothing with other clothing. Wash hats, gloves, and boots daily, and check often to make sure they have no leaks or cracks through which pesticide may enter.

Wear respiratory mask when there is danger of inhaling toxic dust or fumes.

**Preparation of Pesticides.** Pesticide solutions should be prepared in a well-lit place with plenty of ventilation. If possible, it is best to prepare them outdoors. Keep animals and other people away from the area. Wear protective clothing and follow the specified directions carefully. Avoid splashing when mixing the solution. If a spill does occur, soak it up with sawdust, shavings, or soil, and bury the contaminated material in a hole in an isolated place far from ground or surface water supplies.

**Regulations.** Make sure to follow specific laws, regulations, and guidelines for the use of particular pesticides.

## **Application of Pesticides**

Never spray or dust pesticides on windy days or into a breeze. Do not spray with people or animals nearby. Avoid application if bees or other pollinators are active on the site. Be aware that pesticide application in a home garden may affect neighbors' grazing chickens.

## **Timing of Application**

Do not permit unprotected people or animals to enter a site at which pesticides have been applied until sprays have dried or dust has settled. The safe waiting period for most pesticides is 24-48 hours. The following list gives a general guideline for waiting periods for common pesticides. These periods may change considerably as temperature, humidity, and amount of sunlight vary. Check for local specifications if possible.

Pesticide	Recommended Waiting Time
Parathion (ethyl and methyl)	48 hours
Systox (demeton)	48
Azodrin	48
Metasystox-R (oxydemetonmethyl)	48
Trithion (carbophenothion)	48
Guthion (azinphosmethyl)	24
Phosalone	24

**Transportation.** Take precautions to avoid accidental spillage of pesticides. Containers should be properly sealed and fastened and kept away from food, animal feed, and people.

### Storage and Disposal

Store pesticides in a well-ventilated, dry place away from children, food, and animals. Store in secure, clearly labeled containers that are tightly sealed to prevent leakage or release of vapors. If possible, bury empty bag and containers in a sanitary landfill, adding lime to accelerate breakdown.

Place excess pesticides in a hole in an isolated place where they will not contaminate water supplies. Look for an area with thick clay deposits, as this will slow the movement of the pesticides. Add lime to accelerate breakdown, and cover the hole with clay.

Break or crush glass and metal containers before burying. Do not puncture or crush aerosol cans, as they are known to explode. Never use pesticide containers for food or water storage. If someone insists on using them for other purposes, soak and wash containers in a strong detergent, followed by another soaking and washing, followed by rinsing in clean water. The addition of charcoal in the last rinse water and soaking overnight aids to remove traces of chemical.

Do not contaminate water supplies or streams with pesticides during application or when washing equipment. Water left from rinsing or washing should be poured into a hole and buried using the precautions cited above.

**Overexposure to Pesticides.** Avoid repeated or prolonged contact of any pesticide with the skin, or inhalation of dust or sprays. Clothing should be changed and hands and face carefully washed before eating, smoking, or going to the bathroom and after each application. If any part of your body is exposed or contaminated, wash immediately with detergent and clean water.

**First Aid Procedures.** Prevention and education are the best defenses against accidents and injuries. Become familiar with the signs and symptoms of pesticide poisoning and the appropriate first-aid procedures. Keep antidotes within easy reach in case of emergency. Instruct all workers in safety and first aid procedures, (For additional information on treating poisons, see "Where There Is No Doctor," available from ICE.)

### Symptoms of Pesticide Poisoning

The detectable symptoms of pesticide poisoning vary depending on the chemical type of the pesticide and the kind of exposure. Repeated exposure to small amounts of some pesticides can cause a sudden, severe reaction. The onset of symptoms from other types may not occur until several hours after exposure, and the same types of symptoms may result from other illnesses. But if a person has been exposed to pesticides, proper first-aid procedures should not be delayed.

### Identifying the Pesticide

Not all pesticides are properly labeled. They are offered for sale under many different names. Be aware that many pesticides banned in Western countries are sold in developing countries. There are

only about 150 active chemical ingredients in widespread use. These have trade and generic names, and their names may differ in different areas. If a label is available, it should provide information on the chemical composition of the active ingredient. The chemical group to which a pesticide belongs can be determined from the common chemical name used. The label should also state the formulation of the product, toxicity information, and a specific antidote, if any is available,

In case of accident or injury with a pesticide, try to locate and save the label or container and check to see if an antidote or first-aid measures are listed.

### **Steps in Treatment**

The objectives of treatment are as follows:

- Administer the correct antidote, if available;
- Remove poison from the body or from exposed body parts;
- Prevent further absorption and damage; and
- Treat specific symptoms as necessary.

If the type of pesticide absorbed is known and the antidote available, it should be administered as soon as possible. If the antidote is unknown or unavailable, treat the symptoms immediately. Trained medical assistance should be summoned, or the victim should be taken to a medical facility if possible.

Life-threatening symptoms take first priority. These include the following:

- Stopped breathing and swollen chest
- Heart failure
- Central nervous system damage.

Vomiting should not be induced if the victim is obviously mentally confused, if the chemical is caustic (because it can do more harm on the way out), or if the victim is more than six months pregnant. **Never induce vomiting if the person is unconscious or having convulsions.**

To induce vomiting, use one tablespoon of salt dissolved into half a cup of warm water, or use syrup of ipecac. Put the patient in a face-down or kneeling position to prevent choking.

### **Skin Exposure**

Pesticides can be absorbed by the skin if they are spilled or if they seep through clothing. If skin is exposed, it should be washed immediately with large quantities of soap and water. If exposure occurs over a long period of time, a rash may develop due to the pesticide itself or its carrier, which is usually kerosene or petroleum distillates. Rashes related to exposure usually improve when exposure is stopped. Affected areas should be carefully washed, and the person removed from further contact with the substance.

### **Inhalation**

If pesticide dust, fumes or smoke have been inhaled, get the person to fresh air and a space to lie down. Keep the person warm and quiet; check to make sure breathing continues. If breathing stops, apply artificial respiration.

Check for breathing by placing the person face up on a flat surface. Look, listen and feel for signs of breathing. If breathing has ceased execute the following maneuvers:

1. Maintain an open airway by supporting the victim's shoulders and letting the head drop back slightly.
2. Remove any debris or foreign matter from the victim's mouth with your fingers wrapped in a clean cloth.



3. For **adults**: Pinch the victim's nostrils shut and place your mouth tightly over the victim's so that a seal is formed. A cloth should be placed between yours and the victim's mouth so that you do not come in direct contact with the toxic substance.

For **children**: Place your mouth over victim's mouth and nose.

4. Take a breath and exhale into the victim's mouth until you see the chest rise. Smaller breaths will be adequate for children or smaller victims.

5. Remove your mouth, and listen for the air to come out.

6. Repeat this procedure every five seconds for adults or three seconds for children. Continue until automatic breathing resumes or a trained medical person pronounces the victim dead.

**Caution:** Air and gas build-up in the stomach may occur, causing bulging. If so, place the victim's head to one side and press gently on the stomach to force the air to escape. This may cause vomiting. Make sure the airway is not obstructed by foreign matter. If vomiting does occur, turn the victim to the side and wipe out the mouth before repositioning.

### **Eye Exposure**

Eye injuries can result from spilling pesticides, dusting or spraying, or rubbing with contaminated hands. Treatment consists of flushing the eyes from the inside (near the nose) to the outside with large amounts of water or salt solution for several minutes. An eye shield or patch should then be applied if possible, and the person should seek trained medical help.

### **First Aid**

The community forester should be trained in basic first-aid techniques and should make sure that emergency materials are available on site. (For additional information, see "Where There Is No Doctor," available from ICE.)

### **First Aid Supplies**

For poisoning:

- Syrup of ipecac - to induce vomiting
- Activated charcoal - to deactivate or bind poisonous substances
- Epsom salts - laxative

For injuries:

- Bandages
- Sterile gauze pads
- Scissors, tweezers, knife
- Triangular bandages
- Tourniquet
- Adhesive tape
- Clean cotton
- Disinfectant soap
- Alcohol
- Hydrogen peroxide
- White vinegar

Other necessary supplies:

- Thermometer
- Plastic bags
- Sodium bicarbonate (or salt & sugar) to treat dehydration
- Aspirin